



MINUTES

ORDINARY COUNCIL MEETING

27 October 2021

The Chief Executive Officer recommends the endorsement of these minutes at the next Ordinary Meeting of Council.

Signed: .

A handwritten signature in black ink, appearing to be 'J. Murray', is written over a horizontal line.

.....

Date **28 October 2021**

These minutes were confirmed at the Ordinary Council Meeting held on 24 November 2021

Signed:

(Presiding Person at the meeting at which minutes were confirmed)

Acknowledgement of Noongar People

The Shire of Narrogin acknowledges the Noongar people as traditional custodians of this land and their continuing connection to land and community. We pay our respect to them, to their culture and to their Elders past and present.

Naatj ngiyan Birdiya Gnarojin kep unna nidja Noongar Moort ngaala maya nidja boodjera baarlap djoowak karlerl koolark. Ngalak niny ngullang karnan balang Bibolman baalap borong koora wer boorda.

Electronic copies of minutes and agendas are available for download from the Shire of Narrogin website www.narrogin.wa.gov.au

Alternative formats are also available upon request, including large print, electronic format (disk or emailed), audio or Braille



Shire of
Narrogin
Love the life

STRATEGIC COMMUNITY PLAN

SNAPSHOT

2017-27

VISION

A leading regional economic driver and a socially interactive and inclusive community.

MISSION

Provide leadership, direction and opportunities for the community.

KEY PRINCIPLES

In achieving the Vision and Mission, we will set achievable goals and work with the community to maintain a reputation of openness, honesty and accountability. In doing so we will:

- Respect the points of view of individuals and groups;
- Build on existing community involvement;
- Encourage community leadership;
- Promote self-reliance and initiative;
- Recognise and celebrate achievement;
- Support the principles of social justice; and
- Acknowledge the value of staff and volunteers.

OUR VALUES

Care with Trust & Teamwork

Caring - We display kindness and concern for one another and our community

Accountability - We accept responsibility for our actions and outcomes

Respect - We treat everyone how we would like to be treated

Excellence - We go the extra mile to deliver outstanding services

Trust - We share without fear of consequences

Team Work - We work together for a common goal

ECONOMIC



Support growth and progress, locally and regionally...

Growth in revenue opportunities

- Attract new industry, business, investment and encourage diversity whilst encouraging growth of local business
- Promote Narrogin and the Region
- Promote Narrogin's health and aged services including aged housing

Increased Tourism

- Promote, develop tourism and maintain local attractions

An effective well maintained transport network

- Maintain and improve road network in line with resource capacity
- Review and implement the Airport Master Plan

Agriculture opportunities maintained and developed

- Support development of agricultural services

Shire of Narrogin

SOCIAL



Provide community facilities and promote social interaction...

Provision of youth services

- Develop and implement a youth strategy

Build a healthier and safer community

- Support the provision of community security services and facilities
- Advocate for mental health and social support services
- Continue and improve provision of in-home care services

Existing strong community spirit and pride is fostered, promoted and encouraged

- Develop and activate Sport and Recreation Master Plan
- Engage and support community groups and volunteers
- Facilitate and support community events
- Provide improved community facilities (eg library/recreation)
- Encourage and support continued development of arts and culture

Cultural and heritage diversity is recognised

- Maintain and enhance heritage assets
- Support our Narrogin cultural and indigenous community

A broad range of quality education services and facilities servicing the region

- Advocate for increased education facilities for the region
- Advocate for and support increased education services

Minutes Ordinary Council Meeting 27 October 2021

ENVIRONMENT



Conserve, protect and enhance our natural and built environment...

A preserved natural environment

- Conserve, enhance, promote and rehabilitate the natural environment

Effective waste services

- Support the provision of waste services

Efficient use of resources

- Increase resource usage efficiency

A well maintained built environment

- Improve and maintain built environment

CIVIC



Continually enhance the Shire's organisational capacity to service the needs of a growing community...

An efficient and effective organisation

- Continually improve operational efficiencies and provide effective services
- Continue to enhance communication and transparency

An employer of choice

- Provide a positive, desirable workplace

Page | 3

FCEO027

DISCLAIMER

Council and Committee agendas, recommendations, minutes and resolutions are subject to confirmation by the Council or Committee and therefore, prior to relying on them, one should refer to the subsequent meeting of Council or the Committee with respect to their accuracy.

No responsibility whatsoever is implied or accepted by the Shire of Narrogin for any act, omission or statement or intimation occurring during Council/Committee meetings or during formal/informal conversations with staff.

The Shire of Narrogin disclaims any liability for any loss whatsoever and howsoever caused arising out of reliance by any person or legal entity on any such act, omission or statement or intimation occurring during Council/Committee meetings or discussions. Any person or legal entity who acts or fails to act in reliance upon any statement does so at that person's or legal entity's own risk.

In particular and without derogating in any way from the broad disclaimer above, in any discussion regarding any planning application or application for a license, any statement or limitation or approval made by a member or officer of the Shire of Narrogin during the course of any meeting is not intended to be and is not taken as notice of approval from the Shire of Narrogin. The Shire of Narrogin warns that anyone who has an application lodged with the Shire of Narrogin must obtain and should only rely on WRITTEN CONFIRMATION of the outcome of the application, and any conditions attaching to the decision made by the Shire of Narrogin in respect of the application.

Please note that meetings may be recorded for minute taking purposes.

CONTENTS

	Page
1. OFFICIAL OPENING/ANNOUNCEMENT OF VISITORS	6
2. RECORD OF ATTENDANCE/APOLOGIES/APPROVED LEAVE OF ABSENCE	6
3. ELECTION OF DEPUTY PRESIDENT	7
4. DECLARATION OF INTEREST BY ELECTED MEMBERS AND COUNCIL EMPLOYEES IN MATTERS INCLUDED IN THE MEETING AGENDA	7
5. RESPONSE TO PREVIOUS PUBLIC QUESTIONS TAKEN ON NOTICE	8
6. PUBLIC QUESTION TIME	8
7. APPLICATIONS FOR LEAVE OF ABSENCE	8
8. CONFIRMATION OF MINUTES OF PREVIOUS MEETINGS	8
9. ANNOUNCEMENTS BY THE PERSON PRESIDING WITHOUT DISCUSSION	8
10. PETITIONS, DEPUTATIONS, PRESENTATIONS OR SUBMISSIONS	9
11. MATTERS WHICH REQUIRE DECISIONS	11
11.1 DEVELOPMENT AND REGULATORY SERVICES	11
11.1.1 APPLICATION FOR PLANNING CONSENT: PUBLIC AMUSEMENT (PROPOSED DANCE STUDIO) AT LOT 45 (NO. 52) FORTUNE STREET, NARROGIN	11
11.1.2 APPLICATION FOR PLANNING CONSENT: PROPOSED DWELLING ABOVE COMMERCIAL PREMISE AT NO. 88 FEDERAL STREET, NARROGIN	20
11.1.3 OVERSIZE OUTBUILDING AT 21 ARGUS STREET, NARROGIN	34
11.2 TECHNICAL AND RURAL SERVICES	45
11.2.1 PURCHASE OF NEW ROAD MAINTENANCE TRUCK MOUNTED FLOCON	45
11.3 CORPORATE AND COMMUNITY SERVICES	68
10.3.1 SCHEDULE OF ACCOUNTS PAID – SEPTEMBER 2021	68
10.3.2 MONTHLY FINANCIAL REPORTS – SEPT 2021	98
11.4 OFFICE OF THE CHIEF EXECUTIVE OFFICER	117
11.4.1 ESTABLISHMENT OF COUNCIL COMMITTEES AND REFERENCE GROUPS	117
11.4.2 COUNCIL COMMITTEES AND REFERENCE GROUPS PARTICIPATION AND DELEGATES TO EXTERNAL ORGANISATIONS	157
10.4.3 ORDINARY COUNCIL MEETING SCHEDULE	171
11. ELECTED MEMBERS' MOTIONS OF WHICH PREVIOUS NOTICE HAS BEEN GIVEN	174
12. NEW BUSINESS OF AN URGENT NATURE APPROVED BY THE PERSON PRESIDING OR BY DECISION OF THE MEETING	174
13. CLOSURE OF MEETING	174

ORDINARY COUNCIL MEETING

27 OCTOBER 2021

1. OFFICIAL OPENING/ANNOUNCEMENT OF VISITORS

The Presiding Member, President Ballard, declared the meeting open at 7:02 pm,

The Shire President noted that pursuant to clause 8.1 of the Shire of Narrogin Meeting Procedures Local Law 2016 each member has been allocated a seat as indicated by your name place holder.

Should there be any dissent to the allocated seats, the Council will need to determine by consensus an alternative arrangement.

2. RECORD OF ATTENDANCE/APOLOGIES/APPROVED LEAVE OF ABSENCE

Elected Members (Voting)

Mr L Ballard – Shire President (Presiding Member)

Cr T Alexander

Cr G Broad

Cr J Early

Cr M Fisher

Cr R McNab

Cr J Pomykala

Cr B Seale

Cr T Wiese

Staff

Mr D Stewart – Chief Executive Officer

Mr A Awang – Executive Manager Development & Regulatory Services

Mr T Evans – Executive Manager Technical & Rural Services

Mr F Ludovico – Executive Manager Corporate & Community Services

Ms W Russell – Executive Assistant (Acting)

Ms S Guy – Manager Community Leisure and Culture

Mr T Baldwin – Rates Officer

Leave of Absence

Nil

Apologies

Nil

Absent

Nil

Visitors

Ms M Osgood – Left after the presentation of the petition
Ms M Parker – Left after the presentation of the petition
Ms V Ward

3. ELECTION OF DEPUTY PRESIDENT

The Deputy Shire President needs to be elected from within Council for a two-year term, as the first course of business, with the appointment expiring at the October 2023 Ordinary Election.

As the electors of the Shire of Narrogin have elected the Shire President, it is the Elected Members who are required to elect the Deputy President after each ordinary election. The Shire President is required to receive nominations for the position of Deputy Shire President at or before the first available Ordinary Council Meeting in writing to president@narrogin.wa.gov.au or by completing the nomination form sent separately.

The process for determining the result of any election for the position (in the event of there being more than one accepted nomination) will be in accordance with Schedule 2.3 of the Local Government Act 1995. Voting for the position will be by secret ballot and all Councillors in attendance must vote.

If, when the votes cast are counted, there is an equality of votes between two or more candidates who are the only candidates in, or remaining in, the count, the count is to be discontinued and, not more than seven days later, a special meeting of the Council is to be held. Any nomination for the office may be withdrawn and further nominations may be made, before or when the special meeting is held. When the special meeting is held, the Councillors are to vote again on the matter by secret ballot as if they were voting at an election.

The Councillor elected as the Deputy Shire President is to assume the role upon being declared elected and having made the Declaration of Office.

Election

Cr G Broad was nominated for the position of Deputy Shire President. Cr Broad accepted the nomination.

There being no further nominations at the close of the election, the Shire President declared Cr G Broad Deputy Shire President, duly elected for a two year term expiring in October 2023.

4. DECLARATION OF INTEREST BY ELECTED MEMBERS AND COUNCIL EMPLOYEES IN MATTERS INCLUDED IN THE MEETING AGENDA

Name	Item No	Interest	Nature
Cr B Seale	11.1.2	Financial	Owner of the Property and the applicant

5. RESPONSE TO PREVIOUS PUBLIC QUESTIONS TAKEN ON NOTICE

Nil

6. PUBLIC QUESTION TIME

Nil

7. APPLICATIONS FOR LEAVE OF ABSENCE

Nil

8. CONFIRMATION OF MINUTES OF PREVIOUS MEETINGS

OFFICERS' RECOMMENDATION AND COUNCIL RESOLUTION 1021.001

Moved: Cr Seale

Seconded: Cr Early

That the minutes of the Ordinary Council Meeting held on 22 September 2021 be confirmed as an accurate record of the proceedings.

CARRIED 9/0

9. ANNOUNCEMENTS BY THE PERSON PRESIDING WITHOUT DISCUSSION

9.1 – Acknowledgement of Local Government Election Results

The Shire President acknowledged the recent election of Councillors Alexander, McNab, Pomykala, Seale and Wiese. Their swearing in ceremony occurred at 6:30 pm, prior to the Council Meeting, conducted by Mr Azhar Awang, Justice of the Peace.

The Shire President acknowledged the contribution of outgoing elected members, Geoff Ballard, Clive Bartron and Sophie Lushey.

9.2 – Early Bird Rates Prizes Draw

The Early Bird Rates prizes draw was carried out by the Shire President and Executive Manager Corporate & Community Services. All rates that were paid in full by 13 October 2021 and who were qualified to be in the draw pursuant to Council Policy 3.5 Rates – Prize Eligibility will be considered. The winners were drawn using the Shire's SynergySoft 'random prize generator competition' module. The 17 winners drawn are documented in the table below and will be notified in writing.

RATES EARLY PAYMENT PRIZE 2021/22				
Prize	Assessment	Init	Name	Prize
1st	A296700	CT	Cheong	\$1,000
2nd	A312100	M	Ranieri	\$500
Bonus - 1st	A25		CL West Narrogin Pty Ltd	\$100
Bonus - 2nd	A185600	CG	Clouston	\$100
Bonus - 3rd	A302800	DJ	Rasmussen	\$100
Bonus - 4th	A250600	M	Meiners	\$100
Bonus - 5th	A269100	DA	Beggs	\$100
Bonus - 6th	A131100	R	Corasaniti	\$100
Bonus - 7th	A105181	MF	Beros	\$100
Bonus - 8th	A215110	SN	Wells	\$100
Bonus - 9th	A320130	CT	Coffey	\$100
Bonus - 10th	A111300	EA	Kerr	\$100
Bonus - 11th	A129300	DM	Jones	\$100
Bonus - 12th	A616	DW	Wilson	\$100
Bonus - 13th	A101700	EM	Stephens	\$100
Bonus - 14th	A546	WG	Warren	\$100
Bonus - 15th	A161900		E & L Pty Ltd	\$100

10. PETITIONS, DEPUTATIONS, PRESENTATIONS OR SUBMISSIONS

Maretta Osgood presented a petition to Council on behalf of a group of residents concerned about the level of cleanliness at the aquatic centre. The petition contained 83 signatures.

The covering letter stated:

*“A number of residents living in the Shire of Narrogin have identified a cleanliness problem at the aquatic area of our Regional Leisure Center (sic)
Concerned residents have joined forces to put this petition together. It is our goal to put this petition to as many residents as possible. If they share our concerns over the substandard cleanliness of the aquatic center (sic), it is hoped that they will comment and sign. We will be*

writing to the President to allow a citizen group to present this petition to council, hopefully at the next meeting on October 27, 2021.

BACKGROUND : Around the 6th of October, 2021, a question was raised in a facebook group, concerning mould and cleanliness at the aquatic center (sic). Quite a dialogue flowed between members of the group. And the conversation persisted over a couple of days.

*It became apparent that many people had consistently felt let down by the lack of hygiene at the aquatic center (sic). It was said that there was a strong desire to use the facility. But that consistently poor standards of cleanliness put people off. People's health was seen as an issue. People in the discussion thread acknowledged the many different groups in the community rely on the aquatic center (sic). That people might benefit from water physiotherapy, water aerobics, exercise, relaxation and just fun. It was noted that our community has people of all ages and also people with particular special needs. **A desire to see everyone being able to access a safe, clean, hygienic facility was the consensus.***

The people signing this petition, ask the Shire of Narrogin to step in as soon as possible, to raise to the highest standard, the level of cleanliness, in particular, in all wet areas, including showers, toilets, changing rooms and the pool itself.

Author : Marettta Osgood on behalf of concerned residents”.

The Shire President received the petition and requested the Administration to provide a report to the Council in due course regarding it.

11. MATTERS WHICH REQUIRE DECISIONS

11.1 DEVELOPMENT AND REGULATORY SERVICES

11.1.1 APPLICATION FOR PLANNING CONSENT: PUBLIC AMUSEMENT (PROPOSED DANCE STUDIO) AT LOT 45 (NO. 52) FORTUNE STREET, NARROGIN

File Reference	A188500
Disclosure of Interest	Neither the Author nor Authorising Officer have any Impartiality, Financial or Proximity Interests that requires disclosure.
Applicant	Narrogin Dance Centre
Previous Item Numbers	Nil
Date	15 October 2021
Author	David Johnston – Planning Officer
Authorising Officer	Azhar Awang – Executive Manager Development and Regulatory Services
Attachments	<ol style="list-style-type: none">1. Floor Plan2. Extract from Shire of Narrogin Local Heritage Survey 2019

Summary

Council's consideration is requested in regard to the Application for Planning Consent for a proposed dance studio at Lot 45 (No. 52) Fortune Street, Narrogin.

Background

On 24 September 2021, the Shire received an Application for Planning Consent from Narrogin Dance Centre to utilise Lot 45 (No. 52) Fortune Street Narrogin, for a Dance Studio.

The purpose of the business is to teach dance and run fitness classes to students of all ages.

The business is run by two people and no other employees. Class sizes vary from 5 to 25 people.

The subject lot has a total area of 1,108m² and has been a TAFE and showroom in recent years. The proposed dance studio will be located in the main office/showroom section of the lot which is approximately 220m².

Consultation

A site visit was undertaken by the Planning Officer on 15 October 2021.

Under Clause 6.3 of the Former Town of Narrogin Town Planning Scheme No. 2 (FTPS2) for 'PS' uses, Council may give notice of the Application, but is not required to do so.

It is requested that the Council dispense of public advertising as per Clause 6.3 on the basis that similar approvals for businesses that run fitness classes have not attracted any negative feedback.

Statutory Environment

The following statutory documents relate to the proposal:

- Environmental Protection Act 1986
- Environmental Protection (Noise) Regulations 1997
- Planning and Development Act 2005
- Former Town of Narrogin – Town Planning Scheme No. 2
 - Clause 6.3 – Special Approval.

Policy Implications

Nil

Financial Implications

An Application for Planning Consent Fee of \$147 was paid to the Shire of Narrogin.

Strategic Implications

Shire of Narrogin Strategic Community Plan 2017-2027		
Objective	1.	Economic Objective (Support growth and progress, locally and regionally)
Outcome:	1.1	Growth in revenue opportunities
Strategy:	1.1.1	Attract new industry, business, investment and encourage diversity whilst encouraging growth of local business
Strategy:	1.1.2	Promote Narrogin and the Region
Objective	2.	Social Objective (To provide community facilities and promote social interaction)
Outcome:	2.1	Provision of youth services
Strategy:	2.1.1	Develop and implement a youth strategy
Outcome:	2.2	Build a healthier and safer community

Comment/Conclusion

Zoning

Lot 45 (No. 52) Fortune Street, Narrogin is zoned “Central Business” under the FTSP2. The Policy Statement for the zoning states:

“To provide for the function and development of the town centre primarily for retail shops and offices, Council will control the development of other uses and co-ordinate such uses to ensure that compatible development occurs in like areas.”

The proposed Dance Studio falls under the definition of ‘Public Amusement’, which:

“means land and buildings used as a theatre cinema, dance hall, skating rink, squash court, swimming pool, meeting hall or non-residential club or for the playing of active indoor sports.”

Such use is listed as a PS use under the ‘Central Business Zone’, which means:

“Use not permitted unless special approval given by Council and conditions complied with.”

Clause 6.3 – Application for Special Approval of the FTPS2 states as follows:

“6.3.1 The Council shall in the case of an application for permission to carry on a use marked AP in the Development Table and may in the case of an application for permission to carry on a use marked PS in the Development Table or in any other case in which application is made for its approval give notice of the application in accordance with the provisions of this Clause.

6.3.2 Where the Council is required or decides to give notice of an application the Council shall cause:

- a) notice of the proposed use and development to be sent by post or delivered to the owners and occupiers of land within an area determined by the Council as likely to be affected by the granting of the application;*
- b) notice of the proposed use and development to be published in a newspaper circulating in the Scheme Area and in the State of Western Australia stating that submissions may be made to the Council within 21 days from the publication thereof; and*
- c) a sign displaying notice of the proposed use and development to be erected in a conspicuous position on the land for a period of 21 days from the date of publication of the notice referred to in paragraph (b) hereof.”*

Given that there have been a number of fitness class businesses established in the ‘Central Business Zone’ with no negative submissions received during those previous public advertising periods, it is recommended that Council waive the requirement for public advertising as the application is unlikely to attract negative feedback based on previous applications.

Clause 6.3.5 further states:

“6.3.5 A resolution to grant special approval must be passed by an absolute majority of the Council.”

Car parking

Under FTPS2, Public Amusement Uses are required to have 1 car bay per seat. This is not a practical way to assess carparking for this development as classes will be conducted standing and will vary in numbers. Instead, the more appropriate requirement in calculating the carparking in the Central Business Zone, is 1 car bay per 33m² of gross floor area.

Using this method, the 220m² Dance Studio needs to provide seven (7) parking bays. Aerial Imagery shows that there is sufficient space on site to meet this requirement.

Landscaping

The Zoning Table of FTPS2 requires that Central Business zoned lots are to dedicate 7% of the lot to landscaping. There is currently no landscaping on site so this will need to be included in the conditions if approved.

It is noted that in the scheme, in clause 3.3.3, it states:

“3.3.3 LANDSCAPING

Notwithstanding any other provisions of this Scheme, the minimum landscaping required within the Town Centre Area may be a paved area in the form of a courtyard, plaza, arcade or walkway and shall contain such trees, other planting, seating and other furniture as may be determined by the Council.”

Noise

The type of use and activities to be carried out at the premises may generate noise, however the nearest residences are 130m away and noise may be blocked by the police station that sits between the proposed dance centre and residences. The applicant has stated in their cover letter that music will be played during classes which run from 3pm to 8pm most days, however it would be played at a respectable level for the surrounding businesses and nearby residential areas. The building has a double brick wall on the eastern side to prevent noise from disrupting adjoining businesses.

Should complaints be received, it is the applicant’s responsibility to manage noise levels in accordance with the Environmental Protection Act 1986 and the Environmental Protection (Noise) Regulations 1997.

Voting Requirements

Part 1 of 2 – Simple Majority

Part 2 of 2 – Absolute Majority

OFFICERS' RECOMMENDATION AND COUNCIL RESOLUTION 1021.002 (1 OF 2)

Moved: Cr Seale

Seconded: Cr Broad

That, with respect to the Application for Planning Consent: Public Amusement (Proposed Dance Studio), Council dispenses of the requirement to advertise the Application in accordance with Clause 6.3 of the Former Town of Narrogin – Town Planning Scheme No. 2.

CARRIED 9/0

OFFICERS' RECOMMENDATION (2 OF 2)

That, with respect to the Application for Planning Consent: Public Amusement (Proposed Dance Studio), Council approves the Application subject to the following conditions:

1. The approval shall expire if the development permitted is not completed within two years of approval, or within any extension of that time which, upon written application (made before or within 21 days after the expiry of the approval) to the Shire is granted by it in writing.
2. The development approved shall be in accordance with the plans and specifications submitted with the application and these shall not be altered or modified without the prior written approval of the Chief Executive Officer.
3. Any use, additions to and further intensification of any part of the development or land which is not in accordance with the original application or conditions of approval shall be subject to a further development application and consent for that use.
4. All drainage run-off associated with the development shall be contained on site or connected to the Shire's storm water drainage system to the satisfaction of the Chief Executive Officer.
5. All signage is to be in accordance with the Shire of Narrogin's local laws unless further approval is granted by the Shire of Narrogin.
6. Additional landscaping of 75m² shall be provided in accordance with a submitted and approved landscape plan, and implemented within three months of occupancy, to be maintained for the duration of the development, to the satisfaction of the Chief Executive Officer.
7. The use permitted shall not cause injury to or prejudicially affect the amenity of the locality by reason or appearance or the emission of noise.
8. Any outside lighting to comply with Australian Standard AS4282-1997 for the control of obstructive effects of outdoor lighting and not spill into any residential premises.

Advice Note:

1. The applicant is advised that the Council has adopted a Colour Palette and Sign Guide recommending preferred finishes to buildings within the CBD and, indeed, has matching grant funding which could facilitate this, upon successful application, which the applicant is encouraged to consider.

COUNCIL RESOLUTION 1021.003 (2 OF 2)

Moved: Cr Fisher

Seconded: Cr Pomykala

That, with respect to the Application for Planning Consent: Public Amusement (Proposed Dance Studio), Council approves the Application subject to the following conditions:

1. The approval shall expire if the development permitted is not completed within two years of approval, or within any extension of that time which, upon written application (made before or within 21 days after the expiry of the approval) to the Shire is granted by it in writing.
2. The development approved shall be in accordance with the plans and specifications submitted with the application and these shall not be altered or modified without the prior written approval of the Chief Executive Officer.
3. Any use, additions to and further intensification of any part of the development or land which is not in accordance with the original application or conditions of approval shall be subject to a further development application and consent for that use.
4. All drainage run-off associated with the development shall be contained on site or connected to the Shire's storm water drainage system to the satisfaction of the Chief Executive Officer.
5. All signage is to be in accordance with the Shire of Narrogin's local laws unless further approval is granted by the Shire of Narrogin.
6. The use permitted shall not cause injury to or prejudicially affect the amenity of the locality by reason or appearance or the emission of noise.
7. Any outside lighting to comply with Australian Standard AS4282-1997 for the control of obstructive effects of outdoor lighting and not spill into any residential premises.

Advice Note:

1. The applicant is advised that the Council has adopted a Colour Palette and Sign Guide recommending preferred finishes to buildings within the CBD and, indeed, has matching grant funding which could facilitate this, upon successful application, which the applicant is encouraged to consider.

**CARRIED 9/0
BY ABSOLUTE MAJORITY**

Reason for Change: The Officers proposed condition number 6 regarding landscaping was removed, as it was considered unfair to impose the requirement for landscaping, on an already long-established premises, with only the internal use changing.

FLOOR PLAN
52 Federal St

w/c

OFFICE

ATTACHMENT 1

STORAGE

ENTRY

DANCE FLOOR 2

DANCE FLOOR 1

FEDERAL ST

ENTRY

EARL ST

SHIRE OF NARROGIN Local Heritage Survey 2019
GARAGE/SHOWROOM 48 Fortune Street
PLACE No. 86
FORTUNE STREET GROUP Narrogin Town Centre Heritage Protection Area
GRADE B: High level of cultural heritage significance to Shire of Narrogin 'Heritage List.' TPS: Development Application. Retain & conserve.
CONTRIBUTION to HPA: Moderate



Place name	GARAGE/SHOWROOM
Address	48 Fortune Street (northeast cnr Earl Street)
Town/Region	NARROGIN
Lot No	Assessment No.

SHIRE OF NARROGIN Local Heritage Survey 2019
GARAGE/SHOWROOM 48 Fortune Street
PLACE No. 86
FORTUNE STREET GROUP Narrogin Town Centre Heritage Protection Area
GRADE B: High level of cultural heritage significance to Shire of Narrogin 'Heritage List.' TPS: Development Application. Retain & conserve.
CONTRIBUTION to HPA: Moderate

STATEMENT OF SIGNIFICANCE
Garage/showroom is a representative example of Interwar architecture demonstrating that period of commercial development, likely associated with vehicles, that makes a contribution to the Fortune Street context and the historical townscape of Narrogin.

GRADE B: Shire of Narrogin 'Heritage List.' TPS: Development Application. Retain & conserve.

CONSTRUCTION DATE	c.1940
Uses	
CONSTRUCTION MATERIALS:	
Walls	Rendered masonry
Roof	Metal decking
Other	Semidetached gabled shed at the rear on Earl Street frontage.
ARCHITECTURAL STYLE:	
DESCRIPTION:	The unadorned parapet forms three bays with the central one forming a flat apex. The Earl Street view shows a high skillion roof from the parapet. A suspended boxed canopy extends across the entire frontage. The street level frontage comprises three sections with a set of three timber-framed glazed doors in the centre flanked by shop front glazing and highlights, above a dado.
CONDITION: Good	INTEGRITY: Moderate degree AUTHENTICITY: High degree
HISTORICAL NOTES	

LISTINGS	
Department Planning, Lands & Heritage	inherit database No.
Register of Heritage Places	
National Trust classified	
Shire of Narrogin: Heritage Inventory	

SUPPORTING INFORMATION/BIBLIOGRAPHY

7:51 pm – Cr Seale declared a financial interest in the following item and left the meeting.

11.1.2 APPLICATION FOR PLANNING CONSENT: PROPOSED DWELLING ABOVE COMMERCIAL PREMISE AT NO. 88 FEDERAL STREET, NARROGIN

File Reference	A168000
Disclosure of Interest	Neither the Author nor Authorising Officer have any Impartiality, Financial or Proximity Interests that requires disclosure.
Applicant	Oaklands Investments 'WA' Pty Ltd
Previous Item Numbers	Nil
Date	18 October 2021
Author	David Johnston – Planning Officer
Authorising Officer	Azhar Awang – Executive Manager Development and Regulatory Services
Attachments	<ol style="list-style-type: none">1. Floor Plans and Site Plans2. Extract from 2019 Heritage Survey

Summary

Council is requested to consider the Application for Planning Consent for a new dwelling above an existing commercial premise at Lot 43 (No. 88) Federal Street, Narrogin.

Background

On 9 September 2021, the Shire received an Application for Planning Consent from Oaklands Investments for a new dwelling above an existing commercial premise at Lot 43 (No. 88) Federal Street, Narrogin.

The subject lot has a total area of 1,012m². The existing building occupies 415m². The proposed works are largely interior with the exception of private open space which is required by the provisions of the scheme.

The proposal is to refurbish the first floor into a self-contained dwelling comprising of three bedrooms, a study, kitchen and kitchenette, laundry and dining and living area. The internal stairs will be removed and sealed.

The proposal will install an external entrance via an external staircase at the rear of the property.

The ground floor of the building is to continue being used for Commercial purposes.

Consultation

As the proposal which is classed as a 'Commercial Use with Dwelling/Group Dwelling above' is marked as an 'AP' use in the scheme, the proposal must be advertised in accordance with Clause 6.3 of FTFS2.

Clause 6.3 has been quoted in the comments section.

A site visit was undertaken by:

- Executive Manager Development & Regulatory Services
- Building Surveyor.

Statutory Environment

The following statutory documents relate to the proposal:

- Former Town of Narrogin Town Planning Scheme No. 2
- Shire of Narrogin Local Heritage Survey 2019.

Policy Implications

Nil

Financial Implications

An Application for Planning Consent fee of \$480 has been paid to the Shire of Narrogin.

Strategic Implications

Shire of Narrogin Strategic Community Plan 2017-2027		
Objective	1.	Economic Objective (Support growth and progress, locally and regionally)
Objective	3.	Environment Objective (Conserve, protect and enhance our natural and built environment)
Outcome:	3.4	A well maintained built environment
Strategy:	3.4.1	Improve and maintain built environment

Another strategic advantage of this proposal is that activation of the central business district will contribute to keeping it safe outside normal business hours. The Shire should encourage similar projects that improve passive security and improve housing choice.

Comment/Conclusion

Zoning

Lot 43 (No. 88) Federal Street, Narrogin is zoned “Central Business” under the FTSP2. The Policy Statement for the zoning states:

“To provide for the function and development of the town centre primarily for retail shops and offices, Council will control the development of other uses and co-ordinate such uses to ensure that compatible development occurs in like areas.”

The proposed dwelling falls under the use class definition of ‘Commercial use with Dwelling/Group dwelling above’.

Such use is listed as an ‘AP’ use under the ‘Central Business Zone’, which means:

“a use that is not permitted unless special approval is given by the Council after the proposal has been advertised in accordance with Clause 6.3 and it complies with –

- (a) the relevant development standards contained in the Scheme; and*
- (b) all conditions (if any) imposed by the Council in granting planning consent to commence development.”*

Clause 6.3 – Application for Special Approval of the FTPS2 states as follows:

“6.3.1 The Council shall in the case of an application for permission to carry on a use marked AP in the Development Table and may in the case of an application for permission to carry on a use marked PS in the Development Table or in any other case in which application is made for its approval give notice of the application in accordance with the provisions of this Clause.

6.3.2 Where the Council is required or decides to give notice of an application the Council shall cause:

- a) notice of the proposed use and development to be sent by post or delivered to the owners and occupiers of land within an area determined by the Council as likely to be affected by the granting of the application;*
- b) notice of the proposed use and development to be published in a newspaper circulating in the Scheme Area and in the State of Western Australia stating that submissions may be made to the Council within 21 days from the publication thereof; and*
- c) a sign displaying notice of the proposed use and development to be erected in a conspicuous position on the land for a period of 21 days from the date of publication of the notice referred to in paragraph (b) hereof.*

6.3.4 If notices have been given, after the expiration of 21 days from the publication of the notice and after the expiration of 21 days from the posting or delivery of the notices to the owners and occupiers whichever is the later, the Council shall consider the application and decide whether to grant or refuse its special approval or to grant approval upon conditions.

6.3.5 A resolution to grant special approval must be passed by an absolute majority of the Council.”

Residential Design Codes (R-Codes)

While the FTPS2 does not require Central Business Zoned properties to be assessed against the R-Codes, the Administration deemed it suitable to assess it against the R-Codes to ensure that the proposal provides a good level of amenity for future residents. Currently there is no Residential Density Coding applicable to the Central Business zoned area.

It is noted however that the Draft Local Planning Scheme No. 3, is proposing to designate the Town Centre area to R50.

As the proposal is to refurbish the existing first floor for residential purposes, most of the assessment requirements are not applicable, such as boundary setbacks, building heights, street walls and fences. Some of the other items that require assessment are listed below:

Carparking

The minimum permitted parking within the ‘Central Business’ zoning for a ‘commercial use with dwelling above’ is one (1) bay per 33m² of gross floor area.

As the ground floor commercial space is not undergoing any changes, carparking for the residence has been assessed separately. The R-Codes have been judged by the Administration to be the best document for assessing amenities such as carparking for the proposed dwelling. Part 5, Clause C3.1 of the R-Codes provides the minimum number of on-site car parking spaces for each single house.

As the proposed dwelling has three bedrooms and is not located within a walkable catchment of public transport, two car bays are required.

The applicant has proposed a garage with space for one car. If approved, a condition of approval will be that the applicant submit an amended site plan showing the location of the second parking bay.

The subject lot has potential to park a total of 14 car parking bays. Considering that the bottom floor is for Commercial use and that the car parking requirement is 1 car bay for every 33m² of gross floor area, the total Commercial area is approximately (21m x 21m) 441m². This means a total of 13 car bays will be set aside for the Commercial use. On this basis the total number of car bays (13 commercial use and two (2) Residential use) can be adequately provided on site.

It is recommended that the applicant provided a car parking plan of the site.

Outdoor living area

The scheme requires 40m² of private open space to be created for the development of the dwelling. It is proposed that this area can be allocated at the rear of the building with a minimum width and length of 4m. It is recommended that the applicant provided a plan showing the location of the private open space.

Heritage

Under the Shire of Narrogin Local Heritage Survey 2019, Lot 43 (No. 88) Federal Street, Narrogin is heritage listed as Place No. 57. The building is an example of a dominant two-storey Federation building and it contributes to the historical townscape of Narrogin's CBD area.

The place has been listed as a Category B in the Local Heritage Survey. This means:

"A place of considerable cultural heritage significance to Town of Narrogin that is worthy of recognition and protection through provisions of the Town of Narrogin Town Planning Scheme. Planning Application needs to be submitted to Town of Narrogin for any proposed development and referred to Regional Wheatbelt Heritage Adviser for comment. Recommend: Retain and conserve the place. Document the place per HCWA Archive recommendations if retention is not possible."

Clause 2.6.1 'Development Standards' states:

1. *No person shall without the special approval of the Council at or on a Significant and Historic Place:*
 - a. *carry out any development;*
 - b. *demolish a building or structure or damage the significant and historic place;*
2. *Without affecting the generality of any other provision of the Scheme specifying the manner in which the Council is obliged or permitted to deal with an application for development approval, the Council in dealing with any application for development approval may for reasons related to the conservation of a place of cultural heritage significance:*

- a. *refuse approval;*
 - b. *grant approval without conditions; or*
 - c. *grant approval with conditions including conditions aimed at the conservation of the place.*
3. *The provisions of Clause 6.3.2 of the Scheme shall with the necessary modifications having been made, apply to applications under paragraph 1 a) and 1 b) for the special approval of the Council in respect to Significant and Historic Places.*
4. *The Council may give its special approval to the restoration of a Significant and Historic Place notwithstanding that the work involved does not comply with the Building Code of Australia 1990 (as amended), or with the provisions of the Development Table for the Zone or Area in which the Place is situated.*
5. *Any person whose land or property is injuriously affected by a decision of the Council refusing an application for its consent to do any of the things mentioned in paragraph 1 above or granting its consent subject to conditions not acceptable to the applicant may if such refusal or conditions relate to the preservation of the place and if the claim is made within six months of the decision of the Council claim compensation from the Council.*
6. *The purpose and intent of this area is to ensure that any places of value are conserved and that all new development or redevelopment respects in its design and finishes (but not necessarily reproduces) the prevailing character and style of construction, especially those existing elements that best demonstrate historical and architectural integrity and history of the Town.*
7. *In considering any application to commence development the Council shall have due regard for any policy statement of the Council and to the published views of the Heritage Council of Western Australia, the Australian Heritage Commission, the National Trust of Australia (WA) and to the views of those or any other relevant bodies, which views the Council may solicit.”*

The majority of the proposed works are on the interior of the building. A site visit, undertaken by the Executive Manager Development and Regulatory Services and the Building Surveyor, confirmed there is little heritage value on the interior of the building. The exterior of the building especially at the top half is fairly close to the original with the exception of the bright blue paint.

The attached plans show that the only exterior changes will be located at the rear of the building. These include:

- Removal of roller door and replacement with self-closing door on first level.
- New staircase from first floor to garage.
- 40m² or more private open space on ground level behind existing building.

Voting Requirements

Part 1 of 2 – Simple Majority

Part 2 of 2 – Absolute Majority

OFFICERS' RECOMMENDATION AND COUNCIL RESOLUTION 1021.004 (1 OF 2)

Moved: Cr Fisher

Seconded: Cr Wiese

That, with respect to the proposed dwelling above commercial premise at Lot 43 (No. 88) Federal Street, Narrogin, Council publicly advertise the proposal for a period of 21 days in accordance with Clause 6.3 of the Former Town of Narrogin – Town Planning Scheme No. 2.

CARRIED 8/0

OFFICERS' RECOMMENDATION AND COUNCIL RESOLUTION 1021.005 (2 OF 2)

Moved: Cr Fisher

Seconded: Cr Early

That, with respect to the proposed dwelling above commercial premise at Lot 43 (No. 88) Federal Street, Narrogin, if there are no negative comments received at the close of advertising, Council approve the application subject to the following conditions:

1. The approval shall expire if the development permitted is not completed within two years of approval, or within any extension of that time which, upon written application (made before or within 21 days after the expiry of the approval) to the Shire is granted by it in writing.
2. The development approved shall be in accordance with the plans and specifications submitted with the application and these shall not be altered or modified without the prior written approval of the Chief Executive Officer.
3. Any use, additions to and further intensification of any part of the development or land which is not in accordance with the original application or conditions of approval shall be subject to a further development application and consent for that use.
4. All drainage run-off associated with the development shall be contained on site or connected to the Shire's storm water drainage system to the satisfaction of the Chief Executive Officer.
5. A minimum of 40m² of Private Open Space with a minimum width and length of 4m be provided and maintained at all times to the satisfaction of the Chief Executive Officer.
6. The proposed self-closing door on the first level shall be kept locked with a child proof lock when not in use.
7. All signage is to be in accordance with the Shire of Narrogin's local laws, unless further approval is granted by the Shire of Narrogin.
8. The proposed dwelling requires a total of two car bays. The applicant is requested to provide an amended site plan showing the location of one additional parking bay for the approved dwelling and 13 bays for the existing commercial use to the satisfaction of the Chief Executive Officer.
9. Bins and storage areas shall be screened from public view to the satisfaction of the Chief Executive Officer.

Advice Note:

1. The applicant is advised that the Council has adopted a Colour Palette and Sign Guide recommending preferred finishes to buildings within the CBD and, indeed, has matching grant funding which could facilitate this, upon successful application, which the applicant is encouraged to consider.

**CARRIED 8/0
BY ABSOLUTE MAJORITY**

8:05 pm – Cr Seale returned to the meeting

NOTE:

THIS IS NOT A SURVEYORS PLAN. COMPONENTS DRAWN & ALIGNED AS ACCURATELY AS POSSIBLE USING MEASUREMENTS TAKEN FROM A MEASURING TAPE ONLY. ALL DIMENSIONS, LEVELS & LOCATIONS MUST BE CHECKED ON SITE PRIOR TO ANY NEW WORKS COMMENCING.

TERMITE MANAGEMENT NOTE:

LICENCED PEST CONTROLLER TO INSTALL A TERMITE MANAGEMENT SYSTEM IN COMPLIANCE WITH A.S. 3660.1-2014 & THE N.C.C. PART 3.1.4 & TABLE 3.1.4.1 REFER ALSO TO HIA INFORMATION SHEET INCLUDED IN THE NATSPEC WRITTEN SPECIFICATION THAT ACCOMPANIES PLANS

STORMWATER MANAGEMENT NOTE:

ALL GROUND LEVELS ARE TO SLOPE AWAY FROM BUILDINGS. ALL DOWNPIPES ARE TO DIRECT WATER AWAY FROM BUILDINGS BY PLUMBING TO GARDENS, LAWN AREAS, TO RAINWATER TANK/S OR SOAKWELL/S. IN DOING SO, ALL STORMWATER SHALL BE CONTAINED ON SITE & NOT ADVERSELY AFFECT NEIGHBOURING LOTS. STORMWATER KERB OUTLETS ARE SUBJECT TO APPROVAL OF THE SPECIFIC LOCAL SHIRE AUTHORITY.

DIAL BEFORE YOU DIG - VISIT
www.1100.com.au

NOTE:
PLANS SUBJECT TO ENGINEERS CERTIFICATION

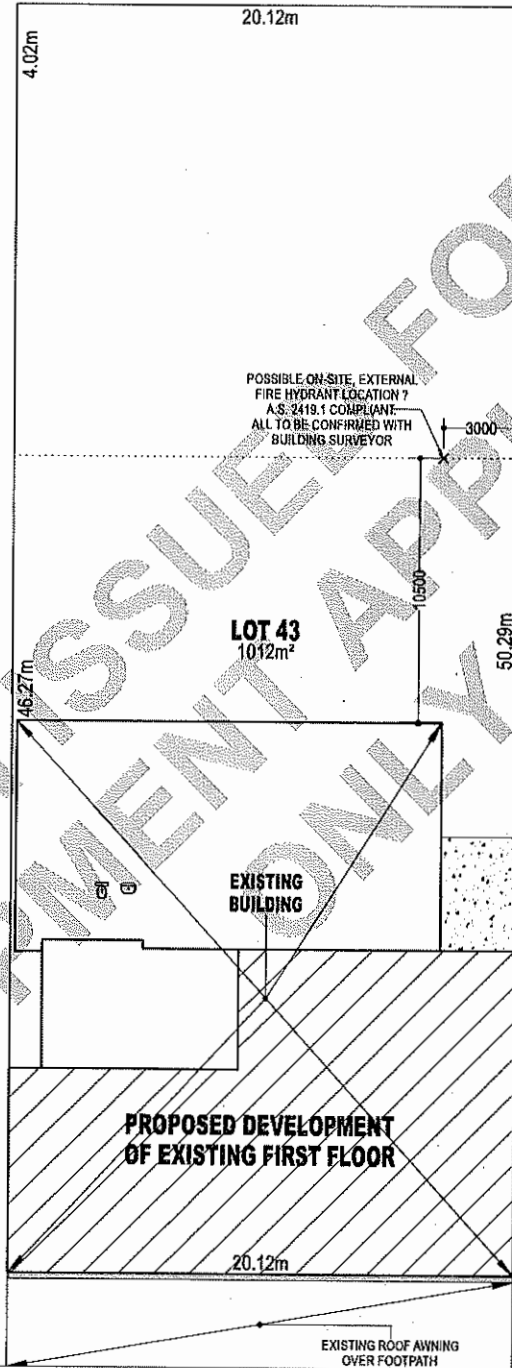

FEDERAL STREET

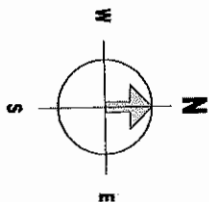

SITE PLAN
SCALE 1:200

DO NOT SCALE FROM DRAWINGS. USE DIMENSIONS SHOWN ONLY.			WEBSITE: www.waynesdesignanddrafting.com.au
JOB TITLE : PROPOSED DEVELOPMENT AT #88, LOT 43 FEDERAL STREET NARROGIN W.A. 6312 DRAWN FOR: B. SEALE	DRAWING TITLE : SITE PLAN		WAYNES DESIGN & DRAFTING DRAFTSMAN : WAYNE BILL A.B.N. 11 593 616 982 3 ELLIS ROAD MERRIEDIN W.A. 6415 PH/FAX (08) 90413 937
	DATE: OCTOBER 2021	DRAWING NO.: 1	
	JOB No: 21016	NO. IN SET: 5	

Copyright ©. All drawings remain the property of Waynes Design & Drafting & must not be reproduced other than for the stated job without written authority of Wayne Bill

EXISTING DIMENSIONS NOTE:
 ALL EXISTING DIMENSIONS INCLUDING
 WALL THICKNESSES MAY VARY
 SLIGHTLY TO THIS PLAN

NOTE:
 ALL DIMENSIONS, LEVELS &
 MATERIALS TO BE CHECKED ON
 SITE PRIOR TO CONSTRUCTION.

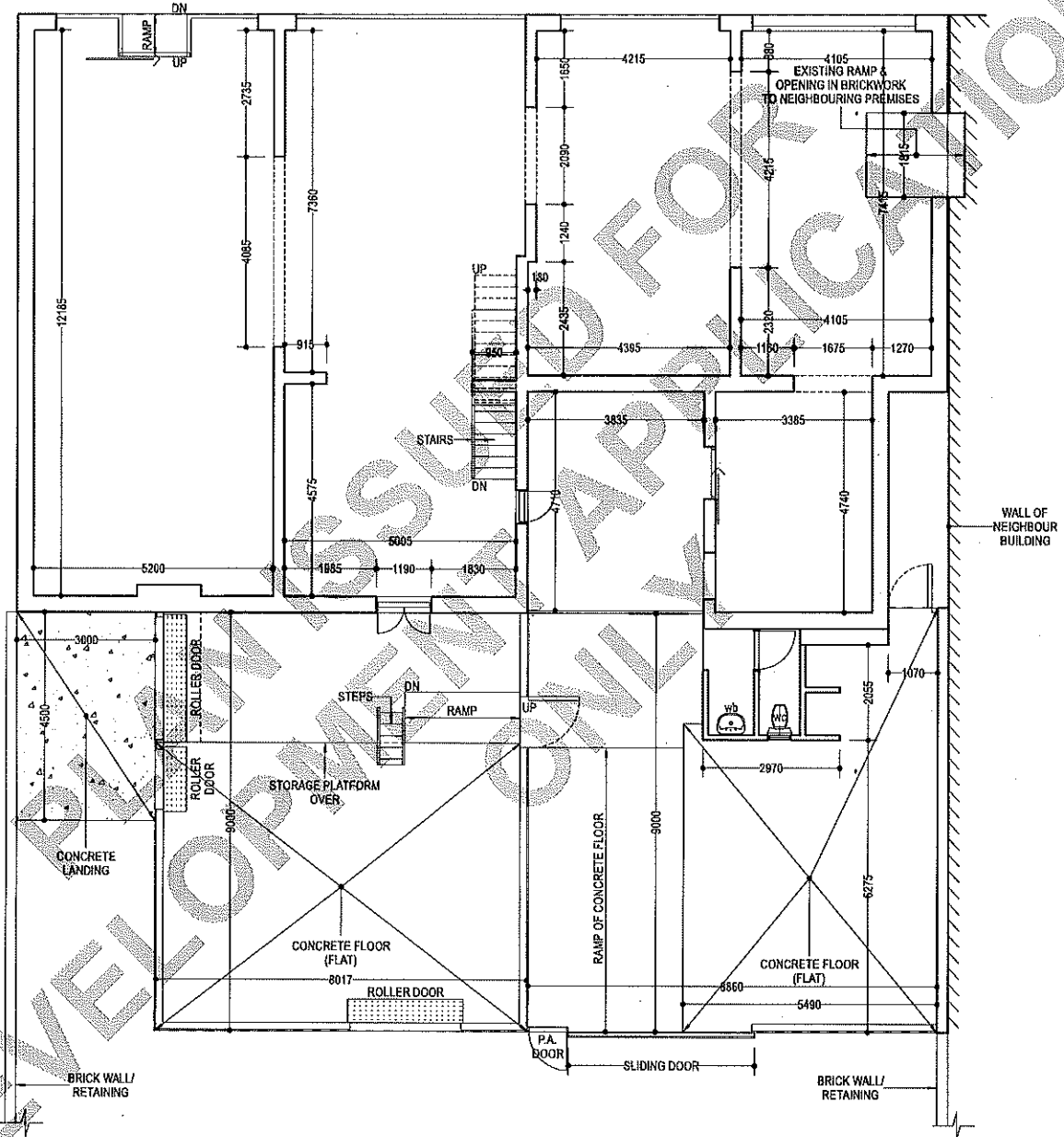

GROUND FLOOR PLAN - EXISTING
SCALE 1:100

BUILDING (GROUND FLOOR) AREA = 488m²

DO NOT SCALE FROM DRAWINGS. USE DIMENSIONS SHOWN ONLY.		WEBSITE: www.waynesdesignanddrafting.com.au	
JOB TITLE : PROPOSED DEVELOPMENT AT #88, LOT 43 FEDERAL STREET NARROGIN W.A. 6312 DRAWN FOR: B. SEALE	DRAWING TITLE : GROUND FLOOR PLAN - EXISTING	WAYNES DESIGN & DRAFTING DRAFTSMAN : WAYNE BILL A.B.N. 11 593 616 982 3 ELLIS ROAD MERREDIN W.A. 6415 PH/FAX (08) 96413 937	
	DATE: OCTOBER 2021		DRAWING NO.: 2
	JOB No: 21016		NO. IN SET: 5
Copyright ©. All drawings remain the property of Waynes Design & Drafting & must not be reproduced other than for the stated job without written authority of Wayne Bill			

EXISTING DIMENSIONS NOTE:
 ALL EXISTING DIMENSIONS INCLUDING
 WALL THICKNESSES MAY VARY
 SLIGHTLY TO THIS PLAN

NOTE:
 ALL DIMENSIONS, LEVELS &
 MATERIALS TO BE CHECKED ON
 SITE PRIOR TO CONSTRUCTION.

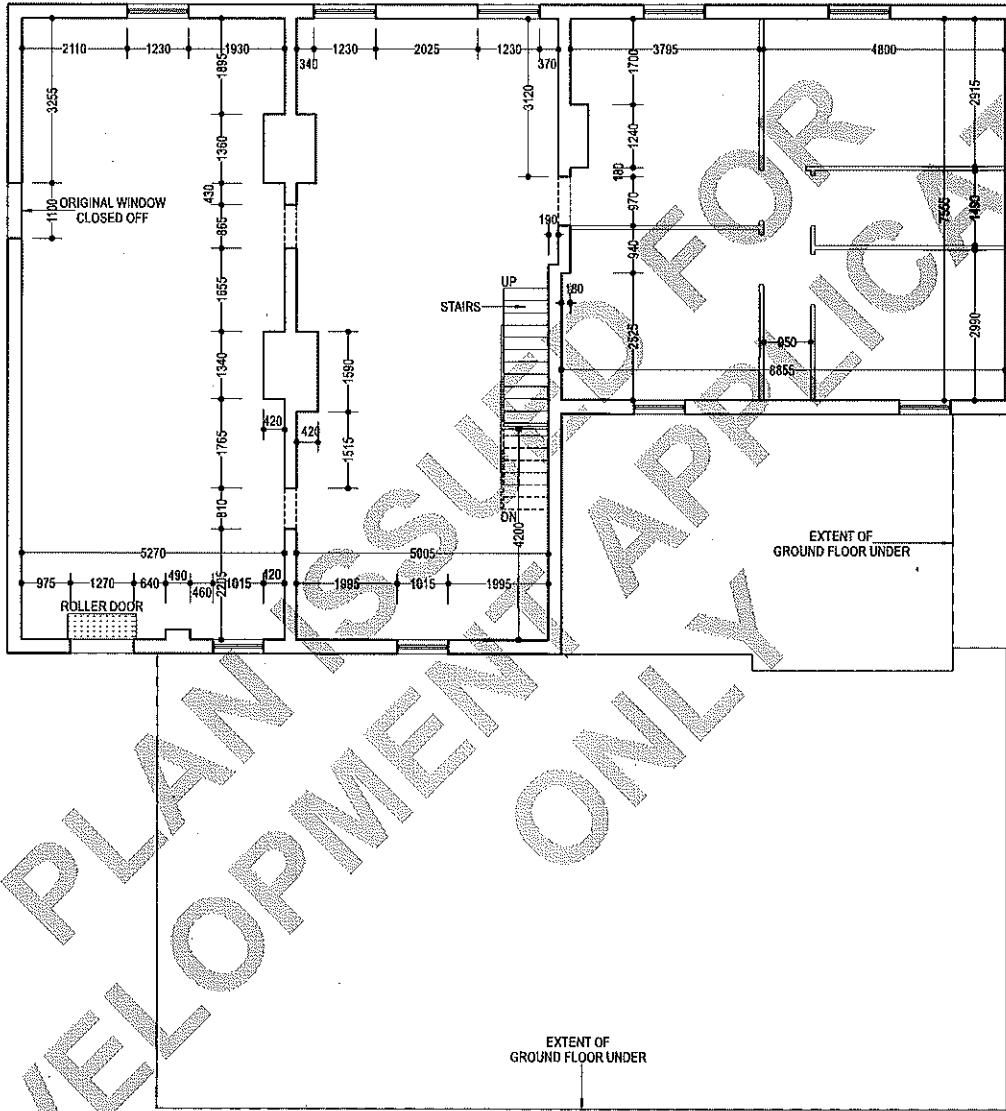

FIRST FLOOR PLAN - EXISTING
 SCALE 1:100

BUILDING (FIRST FLOOR) AREA = 216m²

DO NOT SCALE FROM DRAWINGS. USE DIMENSIONS SHOWN ONLY.		WEBSITE: www.waynesdesignanddrafting.com.au
JOB TITLE : PROPOSED DEVELOPMENT AT #88, LOT 43 FEDERAL STREET NARROGIN W.A. 6312 DRAWN FOR: B. SEALE	DRAWING TITLE : FIRST FLOOR PLAN - EXISTING	
	DATE: OCTOBER 2021	DRAWING NO.: 3
JOB No: 21016	NO. IN SET : 5	
<small>Copyright ©. All drawings remain the property of Waynes Design & Drafting & must not be reproduced other than for the stated job without written authority of Wayne Bill</small>		

EXISTING DIMENSIONS NOTE:
 ALL EXISTING DIMENSIONS INCLUDING
 WALL THICKNESSES MAY VARY
 SLIGHTLY TO THIS PLAN

NOTE:
 ALL DIMENSIONS, LEVELS &
 MATERIALS TO BE CHECKED ON
 SITE PRIOR TO CONSTRUCTION.

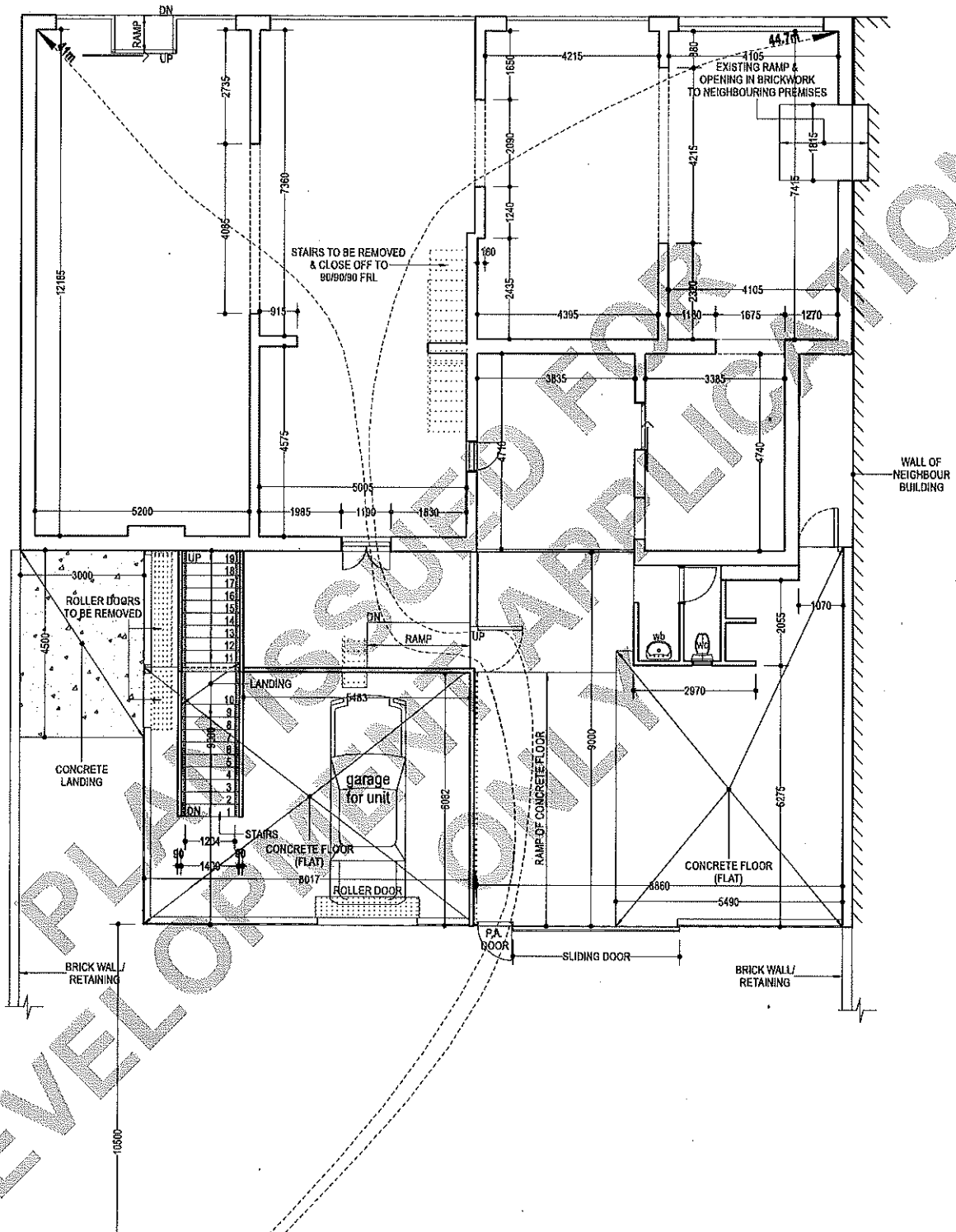

GROUND FLOOR PLAN - PROPOSED
 SCALE 1:100

BUILDING (GROUND FLOOR) AREA = 408m²

POSSIBLE ON-SITE, EXTERNAL
 FIRE HYDRANT LOCATION?
 A.S. 2419.1 COMPLIANT.
 ALL TO BE CONFIRMED WITH
 BUILDING SURVEYOR

DO NOT SCALE FROM DRAWINGS. USE DIMENSIONS SHOWN ONLY.		WEBSITE: www.waynesdesignanddrafting.com.au
JOB TITLE : PROPOSED DEVELOPMENT AT #88, LOT 43 FEDERAL STREET NARROGIN W.A. 6312	DRAWING TITLE : GROUND FLOOR PLAN - PROPOSED	WAYNES DESIGN & DRAFTING DRAFTSMAN : WAYNE BILL A.B.N. 11 593 616 982
DRAWN FOR: B. SEALE	DATE: OCTOBER 2021	
	JOB No: 21016	DRAWING NO.: 4
		NO. IN SET: 5
3 ELLIS ROAD MERREDIH W.A. 6415 PH/FAX (88) 90443 937		

Copyright ©. All drawings remain the property of Waynes Design & Drafting & must not be reproduced other than for the stated job without written authority of Wayne Bill

EXISTING DIMENSIONS NOTE:
 ALL EXISTING DIMENSIONS INCLUDING
 WALL THICKNESSES MAY VARY
 SLIGHTLY TO THIS PLAN

NOTE:
 ALL DIMENSIONS, LEVELS &
 MATERIALS TO BE CHECKED ON
 SITE PRIOR TO CONSTRUCTION.

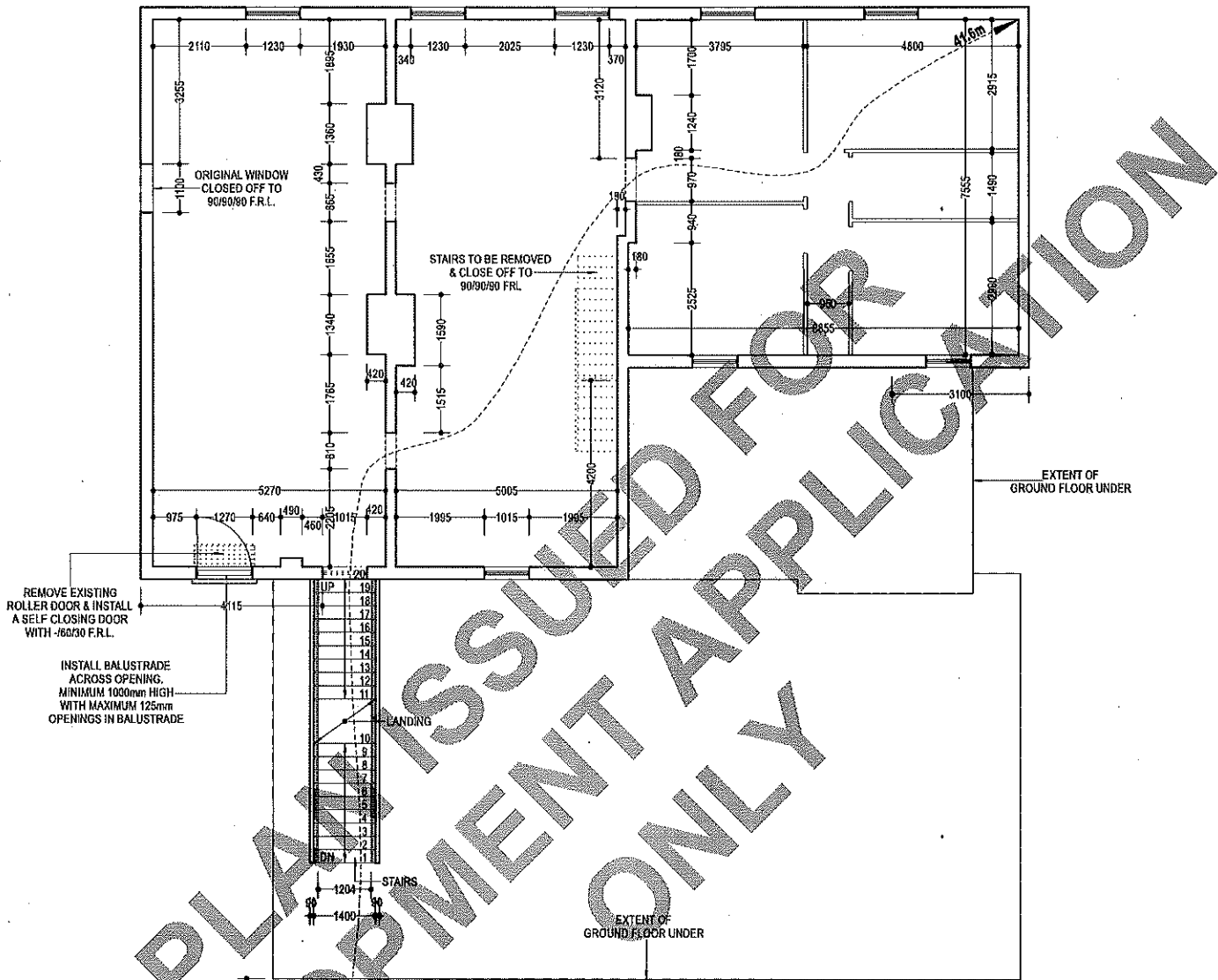

FIRST FLOOR PLAN - PROPOSED
SCALE 1:100

BUILDING (FIRST FLOOR) AREA = 215m²

POSSIBLE ON-SITE, EXTERNAL
 FIRE HYDRANT LOCATION ?
 A.S. 2419.1 COMPLIANT.
 ALL TO BE CONFIRMED WITH
 BUILDING SURVEYOR

DO NOT SCALE FROM DRAWINGS. USE DIMENSIONS SHOWN ONLY.		WEBSITE: www.waynesdesignanddrafting.com.au
JOB TITLE : PROPOSED DEVELOPMENT AT #88, LOT 43 FEDERAL STREET NARROGIN W.A. 6312 DRAWN FOR: B. SEALE	DRAWING TITLE : FIRST FLOOR PLAN - PROPOSED	
	DATE: OCTOBER 2021	DRAWING NO.: 5
JOB No: 21016	NO. IN SET : 5	

Copyright ©. All drawings remain the property of Waynes Design & Drafting & must not be reproduced other than for the stated job without written authority of Wayne Bill

ATTACHMENT 2

SHIRE OF NARROGIN Local Heritage Survey 2019
2 STOREY SHOPS 88 Federal Street
PLACE No. 57 FEDERAL STREET GROUP Narrogin Town Centre Heritage Protection Area
GRADE B: High level of cultural heritage significance to Shire of Narrogin 'Heritage List.' TPS: Development Application. Retain & conserve.
CONTRIBUTION to HPA: Moderate



Place name	2 STOREY SHOPS
Address	88 Federal Street
Town/Region	NARROGIN
Lot No	Assessment No.

STATEMENT OF SIGNIFICANCE

88 Federal Street is a dominant two-storey Federation building that evidences some significant changes over time, but still manages to contribute to the Federal Street context and the historical townscape of Narrogin Town Centre.

GRADE B: Shire of Narrogin 'Heritage List.' TPS: Development Application. Retain & conserve.

CONSTRUCTION DATE	c.1910
Uses	Retail & services
CONSTRUCTION MATERIALS:	
Walls	Rendered masonry
Roof	Not visible
Other	
ARCHITECTURAL STYLE:	Federation

SHIRE OF NARROGIN Local Heritage Survey 2019
2 STOREY SHOPS 88 Federal Street
PLACE No. 57 FEDERAL STREET GROUP Narrogin Town Centre Heritage Protection Area
GRADE B: High level of cultural heritage significance to Shire of Narrogin 'Heritage List.' TPS: Development Application. Retain & conserve.
CONTRIBUTION to HPA: Moderate

DESCRIPTION: The double-storey building presents a symmetrical frontage with a simple parapet. The front wall has 5 equally spaced single double-hung windows at the first floor, below which at ground-floor wall-height are moulded triangular pediments. The suspended canopy across the front of the building partially obscures the pediments. The original 5 shop fronts have been removed and are now an entire intervention of expansive blank frontages and aluminium framed shop front windows.
CONDITION: Good INTEGRITY: Moderate/high degree AUTHENTICITY: Moderate degree
HISTORICAL NOTES

LISTINGS	
Department Planning, Lands & Heritage	inHerit database No.
Register of Heritage Places	
National Trust classified	
Shire of Narrogin: Heritage Inventory	

SUPPORTING INFORMATION/BIBLIOGRAPHY

11.1.3 OVERSIZE OUTBUILDING AT 21 ARGUS STREET, NARROGIN

File Reference	A101700
Disclosure of Interest	Neither the Author nor Authorising Officer have any Impartiality, Financial or Proximity Interests that requires disclosure.
Applicant	Complete Approvals
Previous Item Numbers	Nil
Date	18 October 2021
Author	David Johnston – Planning Officer
Authorising Officer	Azhar Awang – Executive Manager Development and Regulatory Services
Attachments 1. Cover Letter 2. Schedule of Submissions 3. Outbuilding Plans 4. Site Plan	

Summary

Council is requested to consider an Application for Planning Consent for an Oversize Outbuilding at Lot 923 (No. 21) Argus Street, Narrogin.

Background

On 4 August 2021, the Shire of Narrogin received an Application for Planning Consent for an Oversize Outbuilding at Lot 923 (No. 21) Argus Street, Narrogin. The proposal is necessary to house a light rigid (LR) commercial vehicle and for the repair of vintage motorcycles. The proposed outbuilding includes a hoist for conducting repair works.

The proposed outbuilding is to be constructed of steel frame, with Colorbond roof and external cladding. The total area of the outbuilding is 5m wide and 15m in length with a wall height of 5m and ridge height of 5.4m.

Consultation

The applicant was instructed by the Shire that, given the reduced setback and increased height of the proposal, the neighbours on the north side of the proposal would need to be consulted.

The owners of the two neighbouring properties have provided their comments to the Shire. One owner indicated no concerns, while the other listed aspects of the design, that would negatively impact them. The latter comment can be summarised as follows:

- The wall height is significantly higher than other outbuildings in the area
- The plans do not provide details on the finished floor level and the site is on a hill
- The decreased setback and height would create a build up of heat near the respondent's chook pen.

The full comments are included in the schedule of submissions (Attachment 2).

Statutory Environment

Sections of the Acts, Regulations and/or Local Laws that apply to this item include:

- Former Town of Narrogin, Town Planning Scheme No. 2.

Policy Implications

The following policies relate to this item:

- State Planning Policy 7.3 R-Codes Volume 1;
- Local Planning Policy D8 – Oversize Outbuildings;
- Local Planning Policy D9 – Commercial Vehicle Parking.

Financial Implications

An Application for Planning Consent Fee of \$147 was paid to the Shire of Narrogin on 6 August 2021.

Strategic Implications

Shire of Narrogin Strategic Community Plan 2017-2027		
Objective	3.	Environment Objective (Conserve, protect and enhance our natural and built environment)
Outcome:	3.4	A well maintained built environment
Strategy:	3.4.1	Improve and maintain built environment

Comment/Conclusion

Zoning

Lot 923 (No. 21) Argus Street, Narrogin is zoned Single Residential R 12.5 with a total site area of 2017m².

Residential Design Codes (R-Codes)

Part 5.4.3 C3 of the R-Codes states the following Outbuildings are Deemed to Comply:

“Outbuildings that:

- i. Are not attached to a dwelling;*
- ii. Are non-habitable;*
- iii. Collectively do not exceed 60m² in area or 10 percent in aggregate of the site area, whichever is the lesser;*
- iv. Do not exceed a wall height of 2.4m;*
- v. Do not exceed ridge height of 4.2m;*
- vi. Are not within the primary or secondary street setback area;*
- vii. Do not reduce the amount of open space required in Table 1; and*
- viii. Are setback in accordance with Tables 2a and 2b.”*

The proposed outbuilding is compliant with i, ii, vi and vii. It is not compliant with iii, iv, v and viii.

Clause iii has been modified by Local Planning Policy D8 and so an assessment against the Local Planning Policy D8 is required.

Notwithstanding the above 'Deemed to Comply' provisions, the Design Principles, part 5.4.3 P3 of the R-Codes allows *“Outbuildings that do not detract from the streetscape or the visual amenity of residents or neighbouring properties.”*

D8 – Oversize Outbuildings Policy

The Oversize Outbuilding Policy allows for outbuilding sizes that exceed the R-Codes requirements to be approved under delegated authority. The requirements of the Oversize Outbuildings Policy states that in the Single Residential Zone, the following maximum sizes shall apply: *“10% of the lot size or 60m² whichever is the great.”*

Using this to assess the proposal, the maximum outbuilding coverage able to be approved under delegated authority at Lot 923 is 202m². The proposal seeks a total outbuilding coverage of 155m². This is compliant with D8 – Oversize Outbuilding Policy.

Compliance table

The following table summarises each non-compliance and the officer’s comment on each:

	Proposed	Required	Officer’s Comment
Side Setback 1	1.0m	1.7m	There is no justification for the reduced side setback. The reduced impact will negatively affect neighbours on the north side. Recommend increasing setback to 1.7m through the use of planning conditions.
Side Setback 2	23m	1.7m	Compliant
Front setback	37m	7.5m	Compliant
Rear setback	15.3m	6m	Compliant
Wall height	5m	Council discretion required above 2.4m.	An increased setback to 1.7m and screening can mitigate this issue.
Ridge height	5.47m	Council discretion required above 4.2m	An increased setback to 1.7m and screening can mitigate this issue. The ridge height is only 0.47m above the wall height so is unlikely to cause any additional concerns over the wall height.
Colour	Cream walls, zincalume roof	Cream is compliant. Zincalume is not compliant.	Applicant has stated that red could be used instead of zincalume. This would be compliant. However, given the increased wall height, it is recommended that the applicant select a green colour which would help the outbuilding to better blend in with the surroundings.
Maximum outbuilding coverage	155m ²	Max of 202m ²	Compliant

D9 – Commercial Vehicle Parking

The reason for the Outbuilding's increased wall and ridge height is due to the owner needing to store a commercial vehicle on site. The vehicle is a 3.5 tonne Light Rigid vehicle. It is owned by the owner's employer. The owner anticipates that the vehicle will be parked on the property for nine weeks of the year.

The applicant will be advised that the parking of commercial vehicles in residential areas requires planning approval in accordance with Clause 3.6 of FTSP2, Parking and Repair of Commercial Vehicles and Local Planning Policy D9.

It should be noted that whilst approval for the oversize Outbuilding is being recommended, the subsequent use of it, by the applicant, or any other occupier into the future, for parking of a Commercial vehicle, requires a separate Planning Application, as it this is tied to the applicant, and not the land.

Voting Requirements

Simple Majority

OFFICERS' RECOMMENDATION

Moved: Cr

Seconded: Cr

That, with respect to the Application for Planning Consent: Oversize Outbuilding at Lot 923 (No. 21) Argus Street, Narrogin, Council approve the application subject to the following conditions;

1. The approval shall expire if the development permitted is not completed within two years of approval, or within any extension of that time which, upon written application (made before or within 21 days after the expiry of the approval) to the Shire is granted by it in writing.
2. The development approved shall be in accordance with the plans and specifications submitted with the application and these shall not be altered or modified without the prior written approval of the Chief Executive Officer.
3. Any use, additions to and further intensification of any part of the development or land which is not in accordance with the original application or conditions of approval shall be subject to a further development application and consent for that use.
4. All drainage run-off associated with the development shall be contained on site or connected to the Shire's storm water drainage system to the satisfaction of the Chief Executive Officer.
5. The north side setback of the outbuilding is to be increased to 1.7m from the boundary line.
6. Screening in the form of a fast and tall growing tree species is to be planted in the north side setback area within three (3) months of completing the outbuilding and maintained at all times to the satisfaction of the Chief Executive Officer.
7. The outbuilding is to be a green colour in order to blend in with surrounding vegetation and the similar outbuilding at 23 Argus Street. The use of Zinalume and other reflective materials are not permitted.
8. The proposed outbuilding is for domestic purposes only and shall not be used for commercial or habitation purposes.

9. Construction of the outbuilding shall be kept clear from all service connections.

Advice Note:

1. The applicant is advised that the parking of commercial vehicles in residential areas requires planning approval in accordance with Clause 3.6 of FTSP2, Parking and Repair of Commercial Vehicles and Local Planning Policy D9.

COUNCIL RESOLUTION 1021.006

Moved: Cr Early

Seconded: Cr Pomykala

That, with respect to the Application for Planning Consent: Oversize Outbuilding at Lot 923 (No. 21) Argus Street, Narrogin, Council **Refuse** the application for the following reasons:

1. The proposed outbuilding is for the parking of a commercial vehicle and to date no formal approval has been granted for the site. To approve the outbuilding first without considering an application for the parking of Commercial vehicle may be taken that approval will be granted.
2. The wall height of the outbuilding (5m) is above the maximum height permitted (3.0m) in accordance with the Former Town of Narrogin Town Planning Scheme No. 2 clause 3.4.9(a)(iii) and the proposal would be detrimental to the scale and character of the surrounding built environment.
3. The total outbuilding area has exceeded the 75m² allowable under clause 3.4.9(a)(i) of the Former Town of Narrogin Town Planning Scheme No. 2.
4. The ridge height of the outbuilding (5.4m) is above the maximum building height of 4.2m in accordance with clause 5.4.3 C3 Deemed to Comply provisions in the State Planning Policy 7.3 Residential Design Codes.
5. The proposed setback of 1.0m to the north of the boundary is not consistent with the required setback of 1.7m based on the height (5.0m) and length (15.0m) of the proposed outbuilding as required in State Planning Policy 7.3 – Residential Design Codes, Table 2a.
6. The parking of commercial vehicles in residential properties has known detrimental effects on residential amenity such as earlier and later non-traditional times of movement, together with the noise associated with reversing buzzers.
7. There is an objection from an adjoining property owner, citing concerns about a detrimental effect on their peaceful residential amenity associated with such a large structure

CARRIED 9/0



Shire of Narrogin

28th July 2021

RE: 21 Argus Street, NARROGIN

To whom it may concern;

Justification for the proposed shed:

5.4.3 Outbuildings; The proposed shed, with wall height 5m, will not detract from the streetscape or the visual amenity of residents or neighbouring properties as it is located in the rear corner of the property. There are other sheds in the vicinity with the same wall height so it is unlikely to look out of place. The wall height is required for the owner's hoist and 3.2m high truck with aerials.

The proposed shed outbuilding has a floor area of 75m². This brings the total aggregate outbuilding area on the site to ~100m². Although this exceeds the maximum 75m² permitted under the R-Codes, the shed is required to house vehicles and equipment for work purposes and will ensure the longevity of the equipment as it will not be exposed to the elements when being housed in the proposed outbuilding.

Regards,

Kosoula Chase

Submissions	Comment	Officer Comment	Recommendation
Public 1	To whom it may concern, I have no objection to the proposal for the erecting of an outbuilding on the property of 21 Argus Street, Narrogin, WA as identified on Annex A.	Noted.	No change.
Public 2	<ol style="list-style-type: none"> The wall height of the shed (5.0m) is significantly higher than all of the outbuildings on this, and adjacent, properties, and will not be in keeping with the relatively low-profile structures for this area. There are no details for the proposed floor level of the building relative to the natural surface i.e. is the building at natural surface at the eastern end, or in cut to allow the building to be at natural surface at the western end? The block has a significant slope and the floor levels will be critical in assessing how high the building is relative to my property. There is no information about the colour of the north facing wall. 	There are no outbuildings in the surrounding area that reach 5m tall.	Height should be reduced or screening and increased setback provided
		A site visit found that the slopes do increase slightly towards the east. With the increased slopes, the top of the outbuilding would still be in line with existing roof heights when viewed from Argus Street and Homer Street. There would be a large wall height near the respondent's property.	It is recommended that the outbuilding be further setback to 1.7m
		The applicants have stated that the shed will be classic cream and roof is to be zinalume although red is also being considered for the roof.	Zinalume is highly reflective. A darker red option would be more appropriate; however, the applicant will be encouraged to choose a leafy green colour. This would be more in line with existing outbuildings and would blend in better with surrounding trees.

Submissions	Comment	Officer Comment	Recommendation
	<p>4. I am concerned that the proposed height of the structure, the proposed 1.0m offset proximity to the fence, and the colour will cause an excessive build up of heat in the south west corner of my block – this is the location of my chook yard.</p>	<p>The cream colour is unlikely to cause a heat build up but could be somewhat reflective. Given the height and a lack of structures on the south side of the proposed shed, the reduced setback cannot be justified.</p>	<p>The reduced setback should not be allowed.</p> <p>It is unlikely there would be a significant heat effect.</p>
	<p>5. The removal of trees, and the height of the shed will be visually intrusive compared to the current situation.</p>	<p>Agreed.</p>	<p>The shire has no planning policy in relation to retaining trees.</p> <p>The decreased setback cannot be justified and it is recommended that trees be planted to reduce the visual impact of the outbuilding.</p>
	<p>6. There doesn't seem to be any obvious reason for permitting such a high (5.0m) sided shed in a residential area. I note that this is 60% higher than the pre-approved guidelines for outbuildings in residential areas and seems excessive for an outbuilding on a residential property.</p>	<p>The height of the outbuilding is to allow for the parking of a commercial vehicle with antennae.</p> <p>Council has the ability to vary the heights prescribed in the scheme.</p>	<p>The impacts of the increased height can be overcome by an increased setback and screening.</p>
	<p>I would like to request that floor levels of the shed be determined and shown relative to the current property levels before any further considerations are given for the shed to proceed.</p>	<p>Noted.</p>	<p>Floor level details will be required in the assessment of a building application.</p>

Submissions	Comment	Officer Comment	Recommendation
	<p>I would like the structure height reduced to approx. 3.0m wall heights typical of adjacent properties.</p> <p>I request the offset from the existing fence line to the structure be increased to at least the 1.5m offset required for structures greater than 9.0m in length, as per your guidelines, in order to reduce the amount of reflected heat into the south west corner of my property.</p> <p>I note the existing shed at this location is actually 1.2m from the fence – not as shown on the drawings.</p>	<p>The Shire may allow larger outbuilding heights where it does not have an impact on adjoining properties, if it is necessary and where the impacts can be mitigated.</p> <p>The required setback as per the R-Codes is 1.7m</p> <p>Noted.</p>	<p>Conditions for an increased setback and screening can mitigate some concerns about height.</p> <p>The outbuilding is required for the storage of a commercial vehicle.</p> <p>Recommend a setback of 1.7m in the conditions.</p> <p>No impact.</p>

ATTACHMENT 3

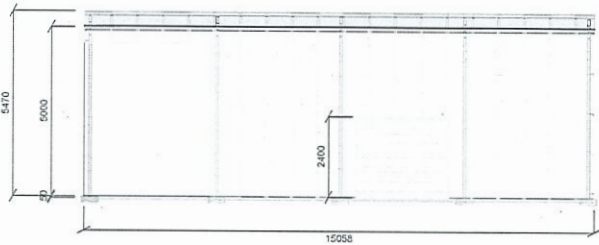

FRONT VIEW

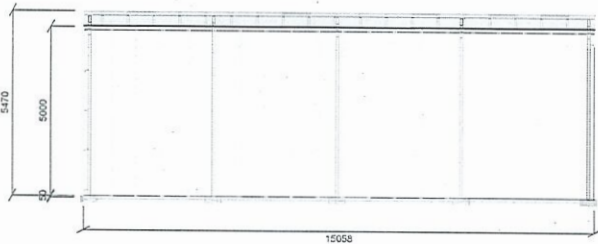

BACK VIEW

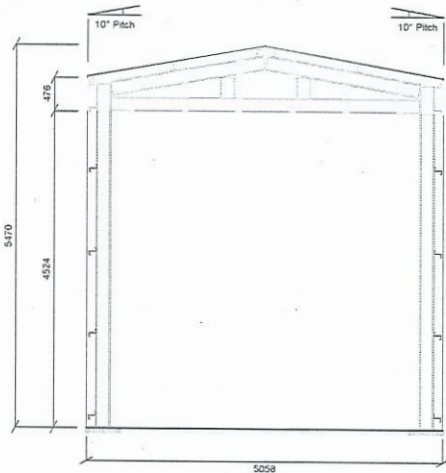

LEFT VIEW

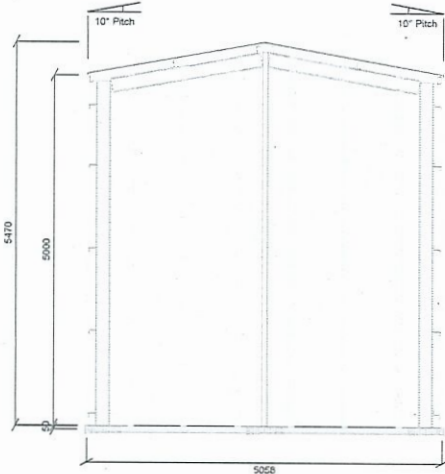

RIGHT VIEW

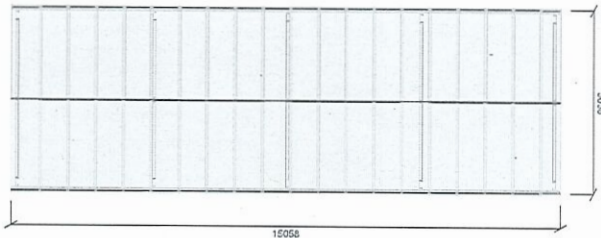

PLAN VIEW

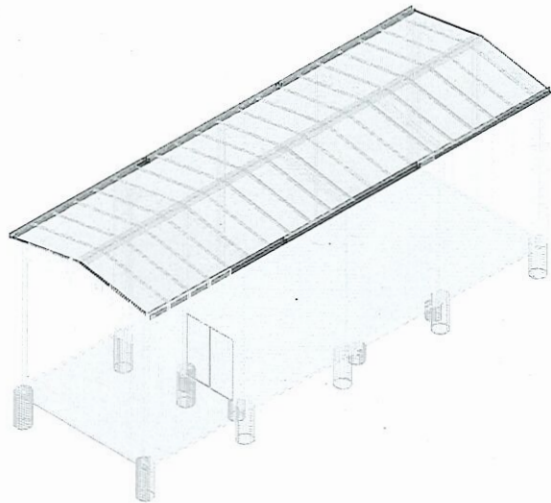

ISO FRONT LEFT VIEW

Elevation Multiview



Signed: 
 Hang Su
 CPEng, MIEA(3911862)

Drawing Number: 1 of 30
Project No: SBT01_256146
Revision: 6 - 13 Jul 2021
21 Argus St
Narrogin, WA 6312
Scale: N/A

© Aussie Outdoor Shed Plus (Design) - Version:1.8.17.1 | Location: sbt01 | User ID: 2 | 13 Jul 2021 @ 10:27 AM

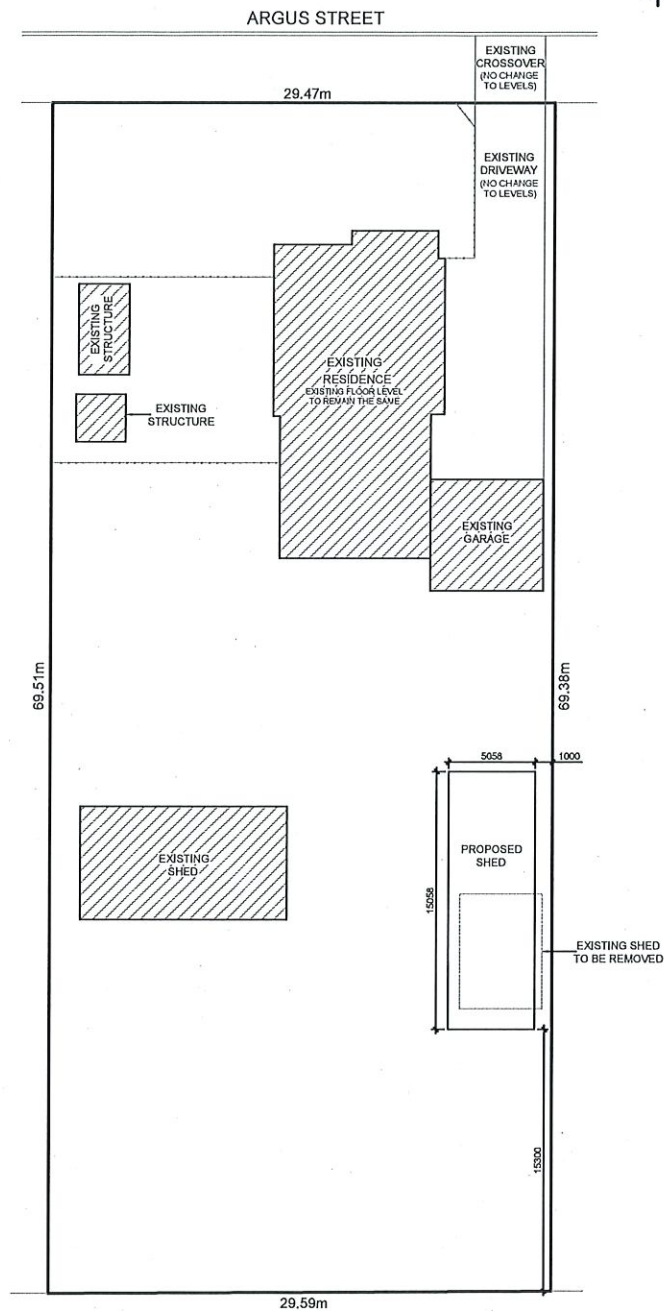
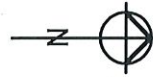

SITE PLAN
SCALE 1:300

©COPYRIGHT

	CLIENT: WAYPOINT OUTDOOR	PROJECT NAME: SHED ADDITION	JOB NO: 2816
	ADDRESS: 21 ARGUS STREET NARROGIN	DWG TITLE: SITE PLAN.	SCALE: AS NOTED
			DRAWN: BM
			REVISION: A

NOTE! DO NOT SCALE THIS DRAWING. IT IS THE BUILDER'S EXPRESS RESPONSIBILITY TO CHECK ALL SITE DIMENSIONS PRIOR TO FABRICATION OR COMMENCEMENT OF ANY WORK.

NOTE! ALL CONSTRUCTION TO BE IN ACCORDANCE WITH ALL ENGINEERS DETAILS, ALL RELEVANT AUSTRALIAN STANDARDS & THE BUILDING CODE OF AUSTRALIA

11.2 TECHNICAL AND RURAL SERVICES

11.2.1 PURCHASE OF NEW ROAD MAINTENANCE TRUCK MOUNTED FLOCON

File Reference	1.2.2
Disclosure of Interest	Neither the Author nor Authorising Officer have any Impartiality, Financial or Proximity Interests that requires disclosure.
Applicant	Nil
Previous Item Numbers	Nil
Date	12 October 2021
Author	Torre Evans – Executive Manager Technical & Rural Services
Authorising Officer	Dale Stewart – Chief Executive Officer
Attachments 1. Evaluation Matrix (Confidential - provided under separate cover) 2. FLOCON Specifications and Information 3. Picture of Current 29 Year-Old Truck Mounted Flocon unit	

Summary

Council is requested to consider awarding the purchase of a new Road Maintenance Truck with a mounted Flocon unit, pursuant to RFQ 21/22-04 to Truck Centre WA, for the sum of \$349,881 ex GST, as per their quotation.

Background

The purchase of a new replacement truck mounted Flocon unit, was identified in the 2020/21 Budget as well as the adopted Plant Replacement Program (2017 to 2027). As the purchase amount for a new Flocon was expected to be in excess of \$150,000, a Request for Quotation (RFQ) was prepared and advertised through the WALGA Preferred Supplier eQuotes Portal, consistent with Council's Purchasing Policy.

Consultation

The RFQ was considered and evaluated by:

- Executive Manager Technical and Rural Services;
- Manager Operations Technical & Rural Services; and
- Maintenance Foreman Technical & Rural Services.

Consultation was also entered into with the Road Reference Group when considering the 2017-2027 Plant Replacement Program which was adopted by Council.

Statutory Environment

Local Government Act 1995 S3.57 – Tenders for Providing Goods or Services.

Local Government (Functions and General) Regulations 1996 Part 4 – Provisions of Goods and Services, Division 2 – Tenders for Providing Goods and Services (s.3.57).

Policy Implications

Policy 3.1 – Purchasing Framework, is applicable.

Financial Implications

The purchase of the new truck with a mounted Flocon unit is wholly contained within the 2021-2022 adopted Budget with an amount of \$350,000 ex GST (PA8215) allocated for the purchase.

The disposal of the current truck and Flocon unit is estimated at \$5,000 (PD8125) and will be disposed of during the year, possibly by public auction.

Strategic Implications

Shire of Narrogin Strategic Community Plan 2017-2027		
Outcome:	1.3	An effective well maintained transport network
Strategy:	1.3.1	Maintain and improve road network in line with resource capacity

Comment/Conclusion

As previously mentioned, the purchase of new truck with a mounted Flocon unit is identified in the 2021 – 2022 adopted Budget and the adopted 2017 – 2027 Plant Replacement Program.

The purchase of the new Flocon unit is to replace the current Flocon unit which is 29 years old, built in 1992, with the current unit well past its useful lifecycle. Parts for the current unit are increasingly difficult to obtain and sometimes cannot be sourced.

The new Flocon unit is a purpose built road maintenance plant, capable of spraying bitumen emulsion from the rear of the truck and spreading aggregate via a spreader box, for the repair of existing bitumen seals as well as sealing newly constructed gravel road pavements for minor projects.

The plant can also perform surface corrections in pavement using hot asphalt or cold mix asphalt which can be utilised for asphalt footpath or road repairs reducing the need to engage contractors.

The Flocon unit can also repair edge breaks in the road seal on the shoulder of a road and in addition, can be used for crack sealing, pot-hole repairs, spreading of lime sand/cement for surface failure stabilisation works and hand spraying tasks with bitumen emulsion. For further details about the Flocon unit, please see Attachment 2.

The new Flocon unit is basically a one plant solution for the vast majority of the Shire's road maintenance tasks and can carry out all functions of the current Flocon unit and the Jet Patcher which are both identified in the adopted 2021-2022 Budget and the 2017-2027 Plant Replacement Program for disposal this financial year. They will both be disposed of during the financial year.

The truck that is identified in Truck Centre WA's submission, that will accommodate the mounting of the Flocon unit is a UD Croner PK 18 280. The Shire currently has UD trucks within its plant fleet for heavy duty road construction and these trucks have proven to be successful over a number of years.

The purchase of the new truck mounted Flocon unit was advertised through the WALGA Preferred Supplier eQuotes Portal to four suppliers from 24 September 2021 to 8 October 2021. The WALGA suppliers that were invited to quote were:

- Truck Centre WA;
- Hino Motor Sales Australia;
- South West Isuzu; and
- Daimler Trucks Perth.

The RFQ was evaluated on 60% price, 25% specification and 15% warranty with Truck Centre WA presenting the best and highest scoring evaluation for their submission.

Flocon is an Australian company, that manufactures that particular type of plant, used by many local governments and private enterprises nation-wide, (see Attachment 2 for referees) within their plant fleet for road maintenance. All suppliers were asked to supply a quotation for an item of plant matching the specifications of a Flocon and a suitable truck for it to be mounted on.

Voting Requirements

Simple Majority

OFFICERS' RECOMMENDATION AND COUNCIL RESOLUTION 1021.007

Moved: Cr Wiese

Seconded: Cr Seale

That Council award the purchase of a new Road Maintenance Truck with mounted Flocon unit, pursuant to RFQ 21/22-04 to Truck Centre WA, for the sum of \$349,881 ex GST, as per their quotation.

CARRIED 9/0



ACN 006 129 040

ABN 19 006 129 040

29 - 31 Apollo Drive, Hallam, Victoria, 3803.

Phone: (03) 9703 2777

Fax: (03) 9703 2933

LONG WHEELBASE MODEL WITH OR 1,000-1,500 LITRE FORWARD EMULSION TANK

4X2 VEHICLE APPROXIMATE DIMENSIONS:

Wheelbase:	5,000 mm.
Cab-Axle:	4,000 mm.
Length of Body:	4,500 mm.
Width of Body:	2,400 mm.
Height of Body:	1,000 mm.
Body Capacity;	4.80 m3.

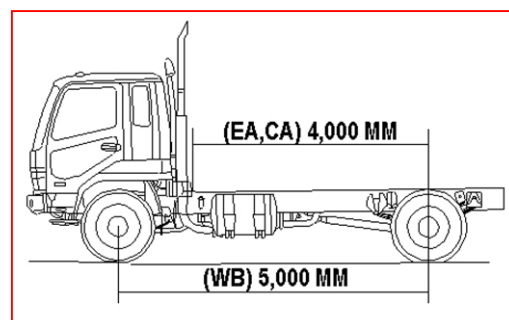

VEHICLE APPROXIMATE WEIGHTS:

Cab Chassis Legal GVM:	16,000 kgs.
Cab Chassis GCM:	32,000 kgs.
Front Axle Capacity:	6,000 kgs.
Rear Axle Capacity:	10,000 kgs.
Tare Weight of 16,000 KG Cab Chassis:	4,650 kgs.
Tare Weight of Body HDCC9:	2,600 kgs.
Tare Weight of Emulsion Tank:	500 kgs.
Tare Weight of 16T Cab Chassis & Body:	7,750 kgs.
Payload of Emulsion Tank:	1,000 kgs.
Approximate Payload 16T Unit:	6,750 kgs.



1 Body Capacity.

The body unit is of **4.80 m3 / 7-8 tonne** capacity and is capable of receiving and discharging a range of products including hot and cold asphalt, sands, soils, gravel, crushed rock, lime, cement up to 75 mm particle size.

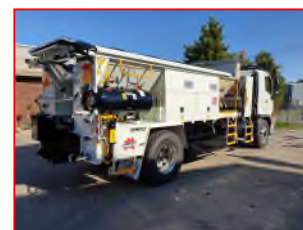

1.1 Body Access Ladder.

A 3 point contact access ladder will be installed on the left or right front sides of the body.



1.2 Air Tailgate.

The unit is fitted with an air cylinder to open and close the tailgate at the rear of the body. The air cylinder opens and closes automatically when the cabin or rear discharge switches are activated on or off. A isolation switch is also fitted at the rear of the body to disengage the air cylinder if the tailboard is required to be open manually.



2 Inbuilt Hydraulic Conveyor.

Our offer includes the supply of an inbuilt hydraulic driven slat conveyor operated from a push pull switch situated in the cabin of the truck and also from the rear of the body by a push button. The conveyor speed is varied by adjustment of a manual speed control lever located in an accessible area on the body. The conveyor is capable of discharging material whether the vehicle is stationary or mobile. The conveyor is able to unload its legal capacity in an even flow without stalling or jamming. The material can be discharged horizontally into any one of the following standard attachments supplied with the body:

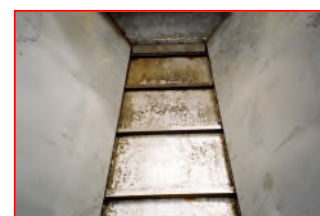

2.1 Directly to the Ground.

Directly to the ground from the rear of the body via the slat conveyor system with an approximate spreading width of 850mm.



2.2 Shovel Bin.

The shovel bin provides the operator with access to shovel material at a comfortable shovelling height of **500 mm**.

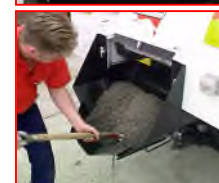

2.3 Rhyll Maker.

Alternatively, the base of the shovel bin can be removed. This allows the material to fall directly through the shovel bin creating a Rhyll spread



2.4 Side Delivery Chute.

A kerb side basic delivery chute is supplied for placing material behind the kerb side wheels only.

(Not outside the vehicle wheel line)

A driver sides basic delivery chute is available as an additional option.



2.5 Full Width Spreading Plate.

The plate is used for basic full width vehicle spreading.

The shovel bin, side chutes and spreading plate are easily removable from the rear of the body.



2 Inbuilt Hydraulic Conveyor. (continued)

2.6 Shovel Cleaning Bin.

Our shovel bin has a capacity for up to two medium sized shovels. The shovels are cleaned by placing 10-15 litres of cleaning fluid in the bin. A hinged splash proof lid minimises spills, and a drainage plug in the base of the bin allows for easy cleaning.



2.7 Witches Hat Stand.

A witch's hat spike is installed to the body with easy access To most common witches' hats



3 Body Heating and Insulation.

3.1 Body Exhaust Heating.

The body floor is channelled and sealed to receive the exhaust gases for the heating of the body direct from the truck engine.



3.2 Exhaust Heating Isolation Valve.

The exhaust system to incorporate a valve to allow the body to be heated or left cold, at the discretion of the operator.



3.3 Body Insulation.

The body sides & floor are fully insulated by a fibre-wool material of a minimum 25 mm thick at 80 Kg/m3 density.

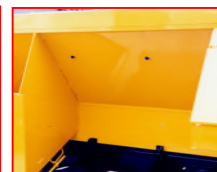

4 Body Hydraulic Operating Systems Available.

4.1 Vehicle Engine Drives and Hydraulic Piston Compensator Pumps. (Only if the live drive outlet is available on the relevant cab chassis)

Our offer includes the supply and installation of a piston compensator pump to fit the already installed live drive engine outlet. The size of the pump or pumps can vary depending on the hydraulic systems requirements for optional body accessories.

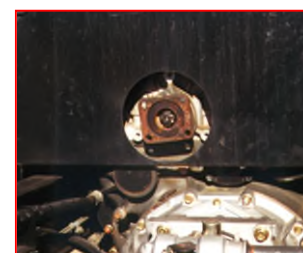

The engines piston compensator pump provides an approximate flow of 37 lpm at 1000 engine revs and a working pressure of up to 210 bar. Electric Cabin controlled.

This engine live drive system will enhance the operation of the Flocon body unit, if available on the cab chassis.

Or;



4 Body Hydraulic Operating Systems Available. (continued)

4.2 Allison 3000/3200/3500 Series Automatic Transmission Power Take Off,s with Single or Dual Hydraulic Gear Pumps.

Our offer includes the supply and installation of a transmission power take off with single or dual hydraulic gear pumps.
The size of the pump or pumps can vary on the units hydraulic requirements.



The automatic transmission PTO, pump or pumps combination provides an approximate flow of 37 lpm at 1000 engine revs and a working pressure up to 210 bar is available. Electric Cabin controlled.

The above automatic transmission models are similar to the live drive engine system where the PTO can be selected either in neutral or in gear with the engine running.

NOTE:

The Allison 2500 series automatic transmissions are only suitable for vehicle stop, start patching tasks if the PTO and pump combination are directly fitted to either of these transmissions. They are not suitable for vehicle moving spreading applications.

4.3 Hydraulic System Specifications.

60-100 litre capacity hydraulic oil tanks are fitted depending on the hydraulic system requirements for optional body accessories.
The hydraulic oil filter is replaceable.
12/24 VDC fan forced hydraulic oil coolers can be supplied depending on the hydraulic system requirements for optional body accessories.



The 12/24vdc hydraulic solenoid body operational control valve supplied on the Flocon unit is our standard "twin system valve".
This allows the hydraulic oil to be supplied and operate two separates body hydraulic functions simultaneously via electric switches.
Typical of this is we can run the main conveyor and one other hydraulic function together.



Additional hydraulic solenoid body operation valves are supplied depending on the hydraulic system requirements for optional body accessories.

4.4 Reverse Main Body Conveyor System.

The main body conveyor system can be reversed enabling the tailboard to be positively locked, avoiding product spillage.
Operation via a electric reverse conveyor push button switch and simultaneously depressing the electric rear discharge button.



5 Storage Compartments.

5.1 1000 mm Storage Locker.

A lockable storage tray constructed on the **left side with gravity emulsion tank fitted. Right side with air emulsion tank fitted.** The locker is a minimum of 1 metre in length. The locker is fitted with a gas strut to assist opening the lid and 'T' bar type locking handle. The storage locker is fitted with stainless steel weather-proof hinge.



5.2 2000 mm Storage Locker.

A lockable storage tray constructed on the **right** side of the body. The locker is a minimum of 2 metres in length. The locker is fitted with gas Struts to assist opening the lid and 'T' bar type locking handles. The storage locker is fitted with stainless steel weather-proof hinge.



5.3 Sign Storage Tray.

Our offer includes the supply of a 3-500mm wide sign storage tray positioned between the front of the body and the rear of the cabin for the full width of the truck. Our sign storage tray provides a proper storage of the basic road sign.



5.4 Left & Right Rear Corner Body Lockers.

Left and right rear corner lockers are supplied, for minor storage items, when rear emulsion and water tanks are not fitted. Left locker normally stores the emulsion reel and the right can store the water reel and or chemical reel. Fitted with key lockable handles. The storage lockers are weather-proof.



5.5 0.25 – 0.5m3 Side Grit/Sand Bin.

A grit or sand bin fitted in the side of the body located on the **right** side of the body. The bin is loaded by shovel and unloaded via a single shovel tray.



5.6 0.25 – 0.5m3 Side Gravity Unloading Spoil Bin.

A spoil bin is built onto the **left** side of the body. The floor of bin is constructed from 3 mm steel and angled at approximately 40 degrees to allow material to run out when the gate is opened.



6 Tarpaulins.

6.1 Bow Tarp Hand Wind.

Our offer includes a ground operational hand wind front to rear PVC body cover with side skirts to correctly fit the body to assist in maintaining product temperature.



7 Emulsion Systems Available.

7.1 1000 Litre Gravity Emulsion Tank.

Our offer includes the supply of a OH & S Authority approved **1000 litre emulsion** storage tank fitted between the vehicle cabin and body. Access steps and standing platform to fill from included.

The emulsion tank is supplied with large inspection plates and accessible filler neck for cleaning and inspection requirements.

The tank is not subject to any air pressure to move emulsion.



7.1.1 Connection Integral Cleaning Tank to Emulsion Pump.

Our offer includes valves and hosing from the integral manufactured tank as part of the emulsion tank, for cleaning the emulsion lines, reel and lance.



7.1.2 Level System to Suit Gravity Emulsion Tanks Only.

The level system consists of a 1-litre nitrile accumulator bladder mounted near the bottom of the emulsion tank connected to a plastic pipe which runs up above the height of the tank. The bladder is filled with a non-toxic environmentally safe fluid with specific gravity similar to the emulsion. As the tank is filled, the fluid is displaced from the bladder into the plastic sight gauge. The level on the pipe follows the level of the fluid in the tank.



7.1.3 High Volume Gravity Pump System Suit 15 Nozzle Emulsion Spray Bar.

The high volume gravity pressure pump system features the reliable impeller centrifugal pump with teflon gland packing.

This packing is suitable for use with emulsion, kerosene, etc.

The pump is operated by a hydraulic motor coupled to the pump.

High volume open impeller 112 Flocon emulsion pump only.

RPM: 3000.

Pressure: 100 kpa.

Flow: 300 lpm.

Tank to Pump Hose Size: 50.0 mm

Pump to Bar Hose Size: 38.0 mm

Coverage up to: 2.0 lt per m2



7.2 50mm Emulsion Tank Filter Strainer Bottom Fill.

50mm camlock connection with inbuilt removable strainer, including Male and Female Camlock installed onto filter base.

Requires 50mm Camlock connection from your bulk tank supply to your emulsion tank filter Camlock fitting.



7.2.1 Replacement Filters Bottom Fill.

Supply of inbuilt spare removable strainer only.



7 Emulsion Systems Available. (continued)

7.3 150mm Nozzle Spacing 2.5 Metre CRS Emulsion Spray Bar. Manual Nozzle Isolation Only.

A **15** nozzle 2.5 metre wide spray bar with an **electric/air** control operated from the vehicle cabin.
Application for accurate emulsion seals up from 1.0 to 2.0 litres per square metre. The 15 nozzles can be isolated individually, manual nozzle isolation only. Facility to clean spray bar only.



7.4 240 Volt Overnight Emulsion Tank Heating.

Our offer includes 240 volt immersion heater fitted into a thermowell. Designed for overnight heating of emulsion in tanks.



Vehicle immobiliser installed to ensure the vehicle cannot be started while the 240 volt system is powered and heating the emulsion. Also fitted with a RCD for personal protection and safety.

A digital temperature gauge and temperature regulated preset thermostat of up to 60 degrees Celsius installed. Digital temperature gauge operating only when powered from a 240 volt source. Tank analogue temperature gauge installed for random temperature checks when the 240 volt heating system is not powered.



7.5 Emulsion Reel and Lance.

The emulsion system includes 7 metres of 19mm hose or 11 metres of 13mm which is stored on a heavy duty all steel spring retractable hose reel. The hand lance has a separate control valve used to turn on and off the emulsion and features the new operator friendly curved end for easier application of the emulsion.

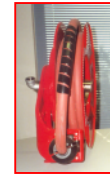

7.6 Single Nozzle Emulsion Spray Lance.

A single nozzle spray lance is available capable of spraying approx 250mm wide, complete with nozzles & shut off/on valves.



Lever Handle

On/Off Valve & Nozzle

Lance Complete

7.7 Chemical Spray System and Steel Hose Reel.

A electric chemical pump is fitted below the tank and connected to a 6 metre chemical hose on a self retracting steel hose reel, spray gun. The spray gun has a adjustable fan nozzle.

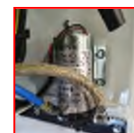

8 Water System.

8.1 Water Tank.

Our offer includes a **100 litre polyurethane water tank** fitted to the **rear of the body cab protector**.

The tank includes a filler neck and cap to top fill or is fitted with a breather to fill from a ground level connection.

A hand tap is supplied on the left and right sides of the body.



8.2 Electric Water Spray System and Plastic Hose Reel.

A electric water pump is fitted below the tank and connected to a 15 metre water hose on a self retracting plastic hose reel, spray gun. The spray gun has a adjustable fan nozzle.



9 Compacting Plate Hydraulic Lifters Available.

9.1 Kerb Side Vibrating Plate, Compacting Plate Raise and Lower Hydraulic Lifter.

Hydraulic operation of the compacting equipment carrier to suit a vibrating plate only.

The hydraulic equipment control moves the stand to the unloading position and also to the correct height for transport. Mechanical locks are provided in the transport position.

Minor manual lifting required onto the carrier while in the down position.



9.2 500 MM Auxiliary Broom.

A auxiliary broom which is fitted to the near side of the vehicle in front of the edge maintenance unit. The broom is fitted with a dust cover. Mounting is in on hydraulic platform, with variable height adjustments and variable broom speed control. **If Room permits for fitting on the vehicle only.**

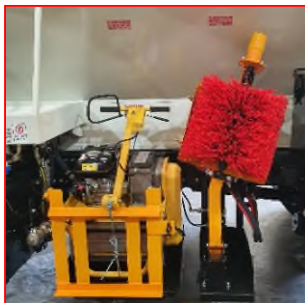

10 Safety Warning Equipment.

10.1 'B' Type LED Single Sided Arrow Board 12/24 Volt.

One single sided 1500 mm x 750 mm directional arrow board 12/24 volt. These arrows provide directional information to the rear of the vehicle only and contain 15 LED lights. 8 amp current draw. 12/24 volt solenoid and air cylinder pressure adjustable to raise and lower the board. Front mounted Pictorial 'Workmen Ahead' logo installed on the board. Includes cabin controller, cables, wiring, brackets and Installation.



10.2 Led Amber Lights.

Two or more LED amber lights of the Customers choice are fitted to each side of the body cab protector either with a Pictorial Workman Sign or Arrow Board as required. The beacons are visual from the front and rear of the vehicle.

Controlled by a switch in the Flocon control panel located in the vehicle cabin. Fitted with a tell tale LED indicator to alert the operator the beacons are on.

The lightss can be also fitted with protective cages to avoid Incidental damage from trees etc....

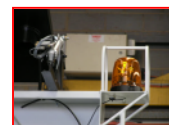

10.3 Colour Dual Rear Vision Camera System.

12-24 volt 5.0" colour monitor fitted in the vehicle cabin and two body mounted cameras. A rear mounted camera enables the driver to sight all operators in a larger arc at the rear of the unit.

The second camera is mounted at the rear of the body cab protector enabling the operator to see into the body hopper to check the amount of product that is present.

The cabin monitor will automatically turn on or switch to the rear camera when reverse gear is selected.



10.4 Marker Plates.

Do Not Over Take Turning Vehicle plates are fitted to the rear of the body on applicable size vehicles only.



10.5 12/24 Volt Reverse Alarm.

(In lieu of standard truck reverse alarm)
77-102 dba self adjusting reverse alarm.



10.6 LED ADR Vehicle Lighting.

Led ADR, taillights, no plate, reverse and side lights.

10.7 Intercom.

Intercom module fitted in the vehicle cabin with external speaker fitted to the rear of the unit. Enabling the rear operators to communicate with the vehicle driver.



11 Spreading Equipment.

11.1 2.5 Metre Automatic Operation Hotmix/Premix Augured Paving Unit.

The paving units function is to spread material to a maximum depth of 150 mm and width from 0.5 metres to 2.5 metres. The paver is forced to the ground via dual adjustable air pressure cylinders. The material is fed to the outer edges of the paver by hydraulically operated left and right augers. Manual controllable left and right blade height adjustments, rear discharge and auger control. 3.0 metre left and right adjustable cast iron travel wheels. Material is fed to the paver via the conveyor rear discharge, cabin or remote controlled. **Adjustable to varying spreading widths.**



12/24 Volt Ultrasonic Sensor to Control Body Conveyor System.

An Ultrasonic Sensor is fitted to the rear EMU back plate with a adjustable maximum sense range of up to 300mm and minimum sense range of 60mm.



The sensor when fitted and adjusted to the required material height in the Paver will automatically stop and start the body conveyor system feeding the Paver, eliminating the manual need to push the rear discharge solenoid button. Easily adjustable sensor heights if required.



Electric & Air Connections Dual Pressure Adjustable Air Cylinders



Hydraulic Motors

Left & Right Augers

Hydraulic Manifold Block

11 Spreading Equipment. (Continued)

11.2 300mm Side Conveyor On Road Edge Maintenance Unit.

This unit places the truck wheels on the road edge to enable spreading, onto the road shoulder of up to 300mm or 500mm wide, with emulsion spraying and sweeping available. Operation of the system is via the vehicle cabin and auto controlled filling of the conveyor.

- A Cabin Control Panel Operation of Edging Unit Functions.
- B Remote Control Operation of EMU Conveyor Feed System.
- C Side Conveyor.
- D 300mm Or 500 mm Side Conveyor Edging Attachment.
- E Pneumatic Emulsion Spray.
- F Hydraulic Operated Transverse Rotating Jib.
- G 500 MM Auxiliary Broom.
- H Hydraulic Raise and Lower Broom Platform Suit Broom.
- I 12/24 Volt Hydraulic Dual Solenoid Valve .
- J 12/24 Volt Hydraulic Oil Cooler.



11 Spreading Equipment. (Continued)

11.3 Auto Aggregate Spreader with Hydraulic Augers With Two Auto Pneumatic Cylinder Door Openers.

A aggregate spreader is fitted to the rear of the unit. The aggregate spreader accurately places 5-14mm aggregates at a chosen preset rate over the emulsion seal.

Spreader width is 2.4 metres with 2 x 600 mm centre doors, 2 x 300 mm left doors and 2 x right 300 mm doors fitted. All the doors can be independently operated. The unit is supplied with two (2) rear shovel points.

The aggregate is fed to the aggregate spreader by the body horizontal conveyor system.

The aggregate spreader is fitted with a split auger, driven by two independent left and right hydraulic motors. The augers move the material from the centre of the spreader to the left and right outer edges. Each auger is fitted with a material sensor switch, which allows the augers to move material independently and automatically, to the outer edges of the spreader ensuring material is kept up to the spreading sequence over the emulsion seal and in the other hand ensuring the spreader is not overfilled. The augers are covered by steel mesh allowing contact with the augers directly.

Two air cylinders operate the gates with a number of spreading widths. Combinations from left to right. Single door operations are carried out by manually releasing the door levers that are not required to open. This unit can be either controlled from the rear of the body or the vehicle cabin automatically.

A limit switch is also provided at the rear of the body tailboard, to control the flow of varying materials into the spreader.

All the functions of the aggregate spreader, body Horizontal conveyor system are controlled by a PLC, which allows the complete system to operate automatically in the correct timings from the vehicle cabin.

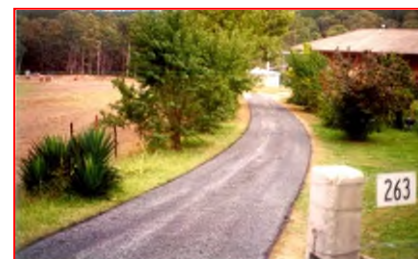
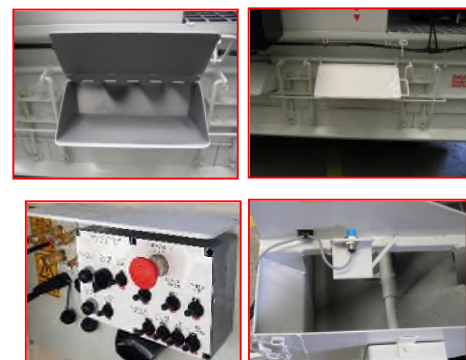

12 Surface Treatment of Body.

Our units and associated equipment are prepared and painted in colour conforming to Australian Standards.
The unit will be painted as follows.

The complete body will be de-slugged from all welding processes by hand. The complete body will be de-slugged from all welding processes by grinder buffing.
The complete body will be degreased.
The complete body will be etch primed by 2-3 coats.
The body then will be painted in 2K CV Autothane paint to match the vehicle cabin or painted to suit the Customers fleet colours.
The rear surface of the body will be painted in 2K CV white to match the vehicle cabin or to a Customer preference white if the main unit is painted a colour other than white.



13 Controls.

All controls for the body inside and outside of the vehicle cabin will be clearly labelled.
Cabin controls will be clearly labelled and within reach by the driver/operator.



14 Installation.

Our offer includes fitting of the completed unit to the cab-chassis including electrical and hydraulic works.
Accurate testing and calibration of the completed unit are carried out.
Our completed unit will conform to State and Federal standards including registration requirements.



15 Noise Levels.

Noise levels of the body and associated equipment except for breakers Comply with OH&S current noise regulations.



16 Instruction Books, Workshop Manuals.

Two copies of workshop manuals and spare parts manuals will be supplied for body, via hard copy, CD format & Usb.



17 Warranty.

Flocon Road Maintenance Equipment is protected by a **2 year unlimited** warranty for new units.
Flocon guarantee that it will either repair or replace free of charge any part that it manufactures and found to be defective in material or workmanship. This warranty is valid from the date Customer takes possession of the unit.



Product Warranty

18 Parts and Service.

Service and spare parts are available from Flocon Engineering P/L outlets as follows;

- Victoria:** Head Office, 29-31 Apollo Drive, Hallam, Vic, 3803.
- Queensland:** 2 Kapyong Rd Caboolture, QLD, 4510.
- Western Australia:** Unit 4/27 Truganina Road, Malaga, 6062.
- Tasmania:** Briar Banks Engineering P/L, Tea Tree.
- New South Wales:** HTE Maintenance and Spares. Riverstone.

Spare parts within 24 hours.



19 Delivery.

Delivery for the above is **38-42 weeks** from the receipt of the Customer Official Written Order.

This delivery is based on our present workload and material supply conditions. These may vary by the time the order is placed and therefore you should confirm this delivery at the time of order placement. Please discuss this delivery with the writer should it present you with a problem.



Completed Delivery Price to Customer Destination

Delivery of the completed units are included in the Total Contract Figure specified at **\$4,000.00 per unit plus GST.**
Ex Melbourne to Customer destination.

Please discuss the delivery charges to your nominated destination with the under writer, should you require to pick up the units yourselves, if so the above figure would be a price reduction from the Total Contract Figure specified.

20 Australian Content.

The Australia content of our Road Maintenance unit is 85%. All manufacturing processes are carried out in our Victoria workshops to adhere to our strict quality procedures.



21 Operator Instruction and Training.

Every Flocon unit is demonstrated to the Customer employees by a fully qualified and experienced representative. The time allowed for the operators instruction is approximately 1 day. We have, however, instructed our representative that he should not leave your premises until Customers operators are confident of the operations. We also provide information for the mechanics and supervisors on body maintenance.



22 Customer Inspection.

Customers are welcome to inspect the progress of the unit at any time.



23 VSB6 Compliant.

The Flocon body is compliant in all facets to VSB6.



24 Research and Design.

Please Note:

**All Manufacturing, Design, Research and Development is produced to suit our Customers individual requirements for their required road maintenance objectives.
Flocon Manufacture equipment to exact Customer requirements.**



25 Manufacturer Risk Assessment.

The Flocon body will be supplied with a manufacturer Risk Assessment before delivery.

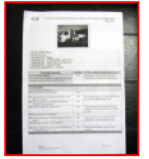

FLOCON UNIT MAINTENANCE COSTS

DAILY MAINTENANCE:

Check water / kero tank level.
Check emulsion tank level.
Check all body lighting and switches.
Check hydraulic oil level.
Clean nozzle on emulsion lance and spray rings.

Labour approximate 30 minutes.

WEEKLY MAINTENANCE:

Check water filter strainer.
Check and adjust main conveyor tension.
Check water / kero tank level.
Check emulsion tank level.
Check all body lighting and switches.
Check hydraulic oil level.
Clean nozzle on emulsion lance and spray rings.

Labour approximate 60 minutes.

MONTHLY MAINTENANCE:

Grease front body shaft bearings.
Grease rear body shaft bearings.
Check water filter strainer.
Check and adjust main conveyor tension.
Check water / kero tank level.
Check emulsion tank level.
Check all body lighting and switches.
Check hydraulic oil level.
Clean nozzle on emulsion lance and spray rings.

Labour approximate 120 minutes.

ANNUAL MAINTENANCE:

Remove and replace hydraulic oil.
Change hydraulic oil filter.
Clean out emulsion tank.

Labour approximate 240 minutes.

Costs hydraulic oil \$3.94 per litre x 50 litres: **\$ 197.00**

Hydraulic Oil Filter: **\$ 164.32**

First Year operational costs approximate Parts only: \$ 500.00

Second Year operational costs approximate Parts only: \$ 800.00

Third Year operational costs approximate Parts only: \$1,300.00

Fourth Year operational costs approximate Parts only: \$2,800.00

Five Year operational costs approximate Parts only: \$4,318.00

Note:

If the machine is maintained and operated correctly the unit should be free of damage other than fair wear and tear.

FLOCON UNIT REFEEREES

FLOCON MULTI PURPOSE UNITS SUPPLIED INTO VIC

CUSTOMER:	MODEL:	YEAR:	CONTACT:	PHONE NO:
Maroondah	HDCC8	2018	Mark	0409 548 702
Banyule	HDCC4	2017	David	0438 234 797
Hume City	HDCC8	2017	Trevor	(03) 9205 2338
Geelong	HDCC8	2017	Ryan	0407 345 902
Wangaratta	HDCC8	2017	Paul	0428 514 303
Wellington	HDCC6	2017	Bruce	0419 594 968
West Wimmera	HDCC8	2017	Shane	0428 415 740
Porter Plant	HDCC8	2018	Alan	0428 888 141
Macedon Ranges	HDCC6	2019	Naresh	0427 865 836
Downer	HDCC8	2019	David	0418 253 535

Hume, Banyule, Yarra, Whittlesea, Frankston, Standard Roads, City Wide, Dandenong, Geelong, Maningham, Porter Plant, Melton, Boral, Emoleum, Bass Coast, Murrindindi, Yarra Ranges, Wangarratta, Hepburn, Wellington, Moorabool, Cardinia, Mildura, Hindmarsh, Campaspe, Yarra Ranges, Pyrenees, Surfcoast, Glen Eira

FLOCON MULTI PURPOSE UNITS SUPPLIED INTO NSW

CUSTOMER:	MODEL:	YEAR:	CONTACT:	PHONE NO:
RMS	HDCCTD15	2018	Ross Woodley	0419 608 100
Wakool	HDCC7	2016	Peter	0429 346 141
Canada Bay	HDCC7	2017	Kevin	0439 455 267
Canterbury	HDCC7	2017		
Waverley	HDCC7	2017		
Leichardt	HDCC6	2017		
Campbelltown	HDCC7	2018	Michael	0418 699 474
Penrith	HDCC4	2018	Bill	0408 293 572
Port Stephens	HDCC7	2018	Paul	0418 973 828
Shoalhaven	HDCC7	2018		
Waverley	HDCC4	2018		
Cumberland	HDCC4	2019	Steve	02 8757 9602
Hilltops	HDCC7	2019		

Blacktown, Holrord, Kiama, Shellharbour, Leichhardt, Canterbury, Sutherland Randwick, Kuringai, Penrith, North Sydney, Canterbury, Kogarah, Tamworth, Woolongong, Holroyd, Hornsby, Auburn, Randwick, Ku-Ring-Gai, Canada Bay, Liverpool, Tweed, Fairfield, Bankstown, Gosford, Transfield, Woolhara, Porter Plant, Bathurst, Berrigan, Urana, Narrabri, Wakool, Byron, Maclean, Dubbo, Walget, Blayney, Taree, Port Stephens, Harden, Young, Armidale, Wollondilly, AH Plant, Musswellbrook, Cabone, Bega, Orange, Wingecarribee, Lithgow, Blayney, Ally Civil, Camden, Snowy Monaro, Sutherland.

FLOCON UNIT REFEEREES

FLOCON MULTI PURPOSE UNITS SUPPLIED INTO QLD

CUSTOMER:	MODEL:	YEAR:	CONTACT:	PHONE NO:
Mackay	HDCC8	2017		
Morton Regional	HDCC6	2017		
Gold Coast	HDCC6	2017	Kris	0439 226 526
Livingston	HDCC6	2016	Tony	0407 399 853
Scenic Rim	HDCC8	2016	Gayanne	07 5540 5288
Toowoomba	HDCC4	2018		
Sunshine Coast	HDCC4	2019	Chris	0417 005 721
Rockhampton	HDCC6	2019	Keith	0417 617 795
Fraser Coast	HDCC7	2020	Neville	0475 811 938
Hinchinbrook	HDCC6	2020	Sam	0427 136 667
Logan	HDCC4	2020	Mitchell	0401 746 595
Townsville	HDCC6	2021		

Brisbane, Noosa, Gold Coast, Toowoomba, Qld Transport, Gladestone, Logan, Rockhampton, Redcliffe, Mackay, Caboolture, Hervey Bay, Maryborough, Bungil, Livingston, Tara, Chinchilla, Beaudesert, Smith Bros, Qld Transport, Thuringowa, Kingaroy, Burdekin, Kilcoy, Maroochy, Warwick, Boonah, Cooloolah, Richmond, Banana, Wondai, Kilkivan, Trucks, North, Jondaryan, Ipswich.

FLOCON MULTI PURPOSE UNITS SUPPLIED INTO WA

CUSTOMER:	MODEL:	YEAR:	CONTACT:	PHONE NO:
Bunbury	HDCC7	2017		
Albany	HDCC7	2017		
Ventia	HDCC7	2017		
Busselton	HDCC7	2017		
Geraldton	HDCC6	2016	Graham	0429 191 582
Moora	HDCC7	2016		
Murry Shire	HDCC6	2016		
Port Hedland	HDCC6	2016		
Swan	HDCC6	2016		
Karratha	HDCC6	2018	Daniel	08 9186 8555
Bunbury	HDCC7	2019		
Geraldton	HDCC7	2019	Graham	0429 191 582
Maundaring	HDCC7	2020	Roger	0429 002 048

MRD Perth, Swan, Victoria Park, Town of Vincent, Cambridge, Melville, Manjimup, Joondalup, Canning, Cockburn, Belmont, Town of Kwinana, City of rockingham, Gosnells, Carnarvon, Kalgoorlie, Murray, BGC Contracting, Greenough, Mandurah, Wanneroo, Vincent, Melville, Town of Victoria Park.

FLOCON UNIT REFEEREES

FLOCON MULTI PURPOSE UNITS SUPPLIED INTO SA

CUSTOMER:	MODEL:	YEAR:	CONTACT:	PHONE NO:
Charles Sturt	HDCC8	2017	Michael	0423 104 492
Playford	HDCC6	2017	Murry	0408 839 755
Onkaparinga	HDCC8	2017	John	(08) 8384 0183
Campbelltown	HDCC4	2016		
Prospect	HDCC4	2016		
Wattle Range	HDCC7	2015	Whittie	0428 601 650
Tea Tree Gully	HDCC7	2018	Wayne	0408 800 897
Unley	HDCC6	2018		
City of Burnside	HDCC7	2019	Andrew	0438 969 038
Holdfast Bay	HDCC4	2019	Ross	0437 946 380
Victor Harbour	HDCC7	2019		
Adelaide Hills	HDCC7	2021		

Port Elliot Goolwa, Burnside, Victor Harbour, Charles Sturt, Adelaide Hills, Campbelltown, Gawler, Salisbury, Alexandrina, Wattle Range, Mount Barker Prospect, Port Adelaide, Tea Tree Gully, Onkaparinga.

FLOCON MULTI PURPOSE UNITS SUPPLIED INTO TAS

CUSTOMER:	MODEL:	YEAR:	CONTACT:	PHONE NO:
Meander Valley	HDCC8	2017	Denis	0427 378 704
Northern Midlands	HDCC8	2017	Lee	0400 120 158
Bernie	HDCC7	2016	Larry	0458 228 337
Clarence	HDCC4/7	2016	Garry	0418 519 041
Launceston	HDCC7	2016	Chris	(03) 6323 356
Kingsborough	HDCC7	2018		
West Tamar	HDCC7	2018		
Central Coast	HDCC7	2021		

Burnie, Devonport, Central Coast, West Tamar, Kingborough, Walter Constructions, Meander Valley, Northern Midlands, Sorell, Derwent.

FLOCON MULTI PURPOSE UNITS SUPPLIED INTO NT

CUSTOMER:	MODEL:	YEAR:	CONTACT:	PHONE NO:
Darwin	HDCC5	2016	Colin	0421 898 105

Current Truck Mounted Flocon



11.3 CORPORATE AND COMMUNITY SERVICES

11.3.1 SCHEDULE OF ACCOUNTS PAID – SEPTEMBER 2021

File Reference	12.1.1
Disclosure of Interest	Neither the Author nor Authorising Officer have any Impartiality, Financial or Proximity Interest that requires disclosure.
Applicant	Nil
Previous Item Numbers	Nil
Date	18 October 2021
Author	Isabella Symonds – Customer Service Officer/Accounts Payable
Authorising Officer	Frank Ludovico – Executive Manager Corporate & Community Services
Attachments	1. Schedule of Accounts Paid – September 2021.

Summary

Council is requested to note the payments as presented in the Schedule of Accounts Paid – September 2021.

Background

Pursuant to Local Government Act 1995, Section 6.8 (2)(b), where expenditure has been incurred by a local government, it is to be reported to the next Ordinary Meeting of Council.

Consultation

Consultation has been undertaken with Manager Corporate Services.

Statutory Environment

Local Government Act 1995, Section 6.8 (2)(b).

Policy Implications

Nil

Financial Implications

All expenditure has been approved via adoption of the 2021/22 Annual Budget, or resulting from a Council resolution.

Strategic Implications

Shire of Narrogin Strategic Community Plan 2017-2027		
Objective	4.	Civic Leadership Objective (Continually enhance the Shire's organisational capacity to service the needs of a growing community)
Outcome:	4.1	An efficient and effective organisation

Comment/Conclusion

The Schedule of Accounts Paid – September 2021 is presented to Council for notation. Below is a summary of activity.

<i>September 2021 Payments</i>		
<i>Payment Type</i>	<i>\$</i>	<i>%</i>
Cheque	542.15	0.06
EFT (incl Payroll)	756,678.48	86.79
Direct Debit	108,020.75	12.39
Credit Card	6,634.38	0.76
Trust	0	0
Total Payments	871,875.76	100

<i>Local Spending</i>	<i>\$</i>	<i>%</i>
Local Suppliers	144,992.22	16.63
Payroll	312,338.46	35.82
Total	457,330.68	52.45

Voting Requirements

Simple Majority

OFFICERS' RECOMMENDATION AND COUNCIL RESOLUTION 1021.008

Moved: Cr Seale

Seconded: Cr Fisher

That with respect to the Schedule of Accounts Paid for September 2021, Council note the Report as presented.

CARRIED 9/0

Cheque Payments

	Chq/EFT/DD	Date	Name	Description	Invoice Amount	Payment Total	Type	Funding
1	594	16/09/2021	Shire Of Narrogin - Petty Cash-admin			\$ 542.15		
2	INV 150921	15/09/2021	Shire Of Narrogin - Petty Cash-admin	NHC PETTY CASH RECOUP - August-September 2021	\$ 302.15			
3	INV 150921	15/09/2021	Shire Of Narrogin - Petty Cash-admin		\$ 165.00			
4	INV 150921	15/09/2021	Shire Of Narrogin - Petty Cash-admin	AGEDOTHER - CATS DRIVER MEALS - Petty Cash Recoup September 2021	\$ 75.00			
Cheque Total \$					542.15			

EFT Payments

	Chq/EFT	Date	Name	Description	Invoice Amount	Payment Total	Type	Funding
5	EFT17068	02/09/2021	Narrogin Hire & Reticulation			\$ 598.00	L	
6	INV 00030923	25/08/2021	Narrogin Hire & Reticulation	MEMBERS - CIVIC FUNCTIONS, REFRESHMENTS & RECEPTIONS - Hire of Tables & Table Clothes (Chamber function 24/08/2021)	\$ 48.00			
7	INV 00030926	30/08/2021	Narrogin Hire & Reticulation	NGN13362 2016 TRAILER - Trailer Hire (August 2021)	\$ 550.00			
8	EFT17069	02/09/2021	Narrogin Packaging			\$ 280.00	L	
9	INV 00070912	18/08/2021	Narrogin Packaging	NGN13077 2008 LOADSTAR TRAILER - Set of Ramps for Trailer x1	\$ 280.00			
10	EFT17070	02/09/2021	Great Southern Fuels			\$ 585.57	L	
11	INV 23/08/2021	23/08/2021	Great Southern Fuels	SMALL PLANT - 400L Unleaded	\$ 585.57			
12	EFT17071	02/09/2021	Narrogin Fruit Market			\$ 617.40	L	
13	INV 0008202108251	25/08/2021	Narrogin Fruit Market	MEMBERS - CIVIC FUNCTIONS, REFRESHMENT & RECEPTIONS - Catering for Workshop with WDC & Pracsys 25/08/2021	\$ 167.40			
14	INV 0008202108252	25/08/2021	Narrogin Fruit Market	MEMBERS - CIVIC FUNCTIONS, REFRESHMENTS & RECEPTIONS - Catering for OCM 25/08/2021	\$ 450.00			
15	EFT17072	02/09/2021	Knightline Computers			\$ 255.58	L	F
16	INV 00074086	30/08/2021	Knightline Computers	CHSP - INFORMATION SYSTEMS - Computer Monitor x1 (Jessie House)	\$ 255.58			
17	EFT17073	02/09/2021	Narrogin Electrical Services			\$ 275.00	L	
18	INV 2084	19/10/2020	Narrogin Electrical Services	PARKS & GARDENS MAINTENANCE - Repair Faulty Contactor for Retic	\$ 275.00			

	Chq/EFT/DD	Date	Name	Description	Invoice Amount	Payment Total	Type	Funding
19	EFT17074	02/09/2021	Mensheds Narrogin Incorporated			\$ 2,500.00	L	
20	INV 100821	10/08/2021	Mensheds Narrogin Incorporated	OTHCUL - COMMUNITY CHEST - Community Chest Application 2020/21	\$ 2,500.00			
21	EFT17075	02/09/2021	Belvedere Nursery			\$ 417.40	L	
22	INV I0000001840	19/08/2021	Belvedere Nursery	PARKS & GARDENS MAINTENANCE - Plants x28	\$ 417.40			
23	EFT17076	02/09/2021	Narrogin Pumps Solar And Spraying			\$ 48.60	L	
24	INV 00036345	24/08/2021	Narrogin Pumps Solar And Spraying	SMALL PLANT - 3/4" Body Split Eyelet (Spray Unit)	\$ 48.60			
25	EFT17077	02/09/2021	Gbr Mechanical			\$ 383.00	L	
26	INV INV-0179	27/08/2021	Gbr Mechanical	ONO 2020 HOLDEN TRAILBLAZER - 48,000km Service	\$ 383.00			
27	EFT17078	02/09/2021	Bladon WA			\$ 1,215.50		
28	INV BWAI48952	30/08/2021	Bladon WA	ADMIN - PRINTING & STATIONERY - Branded Compendiums for Elected Members, Managers & Promotions	\$ 1,215.50			
29	EFT17079	02/09/2021	Ryan Charles Francisco			\$ 2,970.00	L	
30	INV B109	26/08/2021	Ryan Charles Francisco	PRIVATE WORKS SMALL JOBS - Repairs to Paving Near Narrogin Fresh	\$ 2,970.00			
31	EFT17080	02/09/2021	Farmworks Narrogin Pty Ltd			\$ 242.00	L	
32	INV 88301	26/08/2021	Farmworks Narrogin Pty Ltd	VERGE MAINTENANCE - 20Lts Broadleaf Poison	\$ 242.00			
33	EFT17081	02/09/2021	New Ground Water Services Pty Ltd			\$ 45,244.38		
34	INV 1007368	28/08/2021	New Ground Water Services Pty Ltd	TWIS DAMS - Supply & Install Effluent Line (as per RFQ20/21 - 13) (Claim 3)	\$ 45,244.38			
35	EFT17082	02/09/2021	Earl Street Physiotherapy			\$ 152.00	L	F
36	INV 0021000	03/07/2021	Earl Street Physiotherapy	CHCP - CLIENT PURCHASES - Standard Consultation	\$ 75.00			
37	INV 0022170	15/07/2021	Earl Street Physiotherapy	CHCP - CLIENT PURCHASES - Standard Consultation	\$ 77.00			
38	EFT17083	02/09/2021	Jennifer Fowler			\$ 970.00		F
39	INV 151	23/07/2021	Jennifer Fowler	CHCP - CLIENT PURCHASES - Consultation with Occupational Therapist	\$ 970.00			
40	EFT17084	02/09/2021	Jessica Kennedy Acupuncture			\$ 100.00		F
41	INV 000092	12/08/2021	Jessica Kennedy Acupuncture	CHCP - CLIENT PURCHASES - Acupuncture Appointment	\$ 100.00			

	Chq/EFT/DD	Date	Name	Description	Invoice Amount	Payment Total	Type	Funding
42	EFT17085	09/09/2021	Best Office Systems			\$ 1,938.71	L	PF
43	INV 591911	26/08/2021	Best Office Systems	VARIOUS DEPARTMENTS - Photocopier Charges (20/07/2021-20/08/2021)	\$ 1,938.71			
44	EFT17086	09/09/2021	Landgate			\$ 733.64		
45	INV 367635-10001100	20/08/2021	Landgate	RATES - VALUATION EXPENSES - GRV Interim Valuation Shared (26/06/2021-23/07/2021)	\$ 74.64			
46	INV 112221-1001100	30/08/2021	Landgate	RATES - VALUATION EXPENSES - Other DLI Invoices x8	\$ 659.00			
47	EFT17087	09/09/2021	Narrogin Earthmoving & Concrete Pty Ltd Atf The Mcnab Family Trust			\$ 1,320.00	L	
48	INV IV00000001284	13/07/2021	Narrogin Earthmoving & Concrete Pty Ltd Atf The Mcnab Family Trust	FOOTPATH MAINTENANCE - Supply & Lay Concrete (Driveway Repair)	\$ 1,320.00			
49	EFT17088	09/09/2021	Bucher Municipal Pty Ltd - McDonald Johnston			\$ 1,560.13		
50	INV 1010923	16/08/2021	Bucher Municipal Pty Ltd - McDonald Johnston	1EUF156 HINO ROAD SWEEPER 2004 - Wheel Assembly for Sweeper Snorkel	\$ 509.05			
51	INV 1011974	26/08/2021	Bucher Municipal Pty Ltd - McDonald Johnston	1EUF156 HINO ROAD SWEEPER 2004 - Bulk Parts Washers, Nuts Screws, Clamp Block & Pivot Nozzle	\$ 262.83			
52	INV 1012393	31/08/2021	Bucher Municipal Pty Ltd - McDonald Johnston	1EUF156 HINO ROAD SWEEPER 2004 - Cylinder for Wide Sweep Broom	\$ 788.25			
53	EFT17089	09/09/2021	Air Response			\$ 1,942.00	L	
54	INV 154024A	15/08/2021	Air Response	CAFE 45 FEDERAL STREET BUILDING MAINTENANCE - Half the Cost of Split System Air conditioner	\$ 1,942.00			
55	EFT17090	09/09/2021	Goodyear Dunlop Tyres Pty Ltd (Beaurepaires)			\$ 90.00	L	
56	INV 6412184851	31/08/2021	Goodyear Dunlop Tyres Pty Ltd (Beaurepaires)	NO01 2019 HOLDEN COLORADO - Tyre Repair Materials	\$ 90.00			
57	EFT17091	09/09/2021	Narrogin Amcal Chemist			\$ 30.70	L	F
58	INV 887851	05/08/2021	Narrogin Amcal Chemist	CHSP - GENERAL EXPENSITURE - Dressing Packets x3 (Jessie House)	\$ 8.85			
59	INV 885483	26/08/2021	Narrogin Amcal Chemist	CHCP - CLIENT PURCHASES - Medication Organiser	\$ 7.95			
60	INV 893234	01/09/2021	Narrogin Amcal Chemist	CHCP - CLIENT PURCHASES - Medication Dispensers x 2	\$ 13.90			
61	EFT17092	09/09/2021	Local Government Professionals Australia WA			\$ 880.00		
62	INV 31319	18/08/2021	Local Government Professionals Australia WA	ADMIN - TRAINING & DEVELOPMENT - Induction to Local Government Training Module (10 Employees)	\$ 880.00			
63	EFT17093	09/09/2021	New Security Installations Pty Ltd			\$ 915.20		
64	INV 00014335	01/09/2021	New Security Installations Pty Ltd	LYDEKER DEPOT BUILDING OPERATIONS - Alarm Monitoring (13/10/2021-12/10/2022)	\$ 915.20			

	Chq/EFT/DD	Date	Name	Description	Invoice Amount	Payment Total	Type	Funding
65	EFT17094	09/09/2021	WA College of Agriculture - Narrogin			\$ 100.00	L	
66	INV 19970	31/08/2021	WA College of Agriculture - Narrogin	MEMBERS - DONATIONS TO COMMUNITY GROUPS - Student Awards Sponsorship 2021 - With Thanks	\$ 100.00			
67	EFT17095	09/09/2021	Bob Waddell & Associates Pty Ltd			\$ 99.00		
68	INV 2434	29/08/2021	Bob Waddell & Associates Pty Ltd	ADMIN - CONSULTANTS - Assistance with Rates Enquiries & Tasks (29/08/2021)	\$ 99.00			
69	EFT17096	09/09/2021	P.H & K.E Gow			\$ 1,752.30	L	
70	INV 2589	14/07/2021	P.H & K.E Gow	PLAN - CONTRACT TOWN PLANNING - Drainage Easement Lot 850 Falcon Street	\$ 1,752.30			
71	EFT17097	09/09/2021	Marketforce Pty Ltd			\$ 1,429.71		
72	INV 40233	25/08/2021	Marketforce Pty Ltd	PLAN - ADVERTISING - Draft Local Planning Scheme 3 Narrogin Observer 19/08/2021	\$ 392.83			
73	INV 20234	25/08/2021	Marketforce Pty Ltd	COMMUNITY - RECRUITMENT - Advertising Position (Community Development Support Officer) Narrogin Observer 19/08/2021	\$ 308.70			
74	INV 40235	25/08/2021	Marketforce Pty Ltd	PWO - WORKS - Advertising Position (Plant Operator/General Hand) Narrogin Observer 18/08/2021	\$ 288.62			
75	INV 14737	25/08/2021	Marketforce Pty Ltd	MEMBERS - ADVERTISING & PROMOTIONS - Notice of Annual General Meeting of Electors - August 2021 - Narrogin Observer	\$ 219.78			
76	INV 40231	25/08/2021	Marketforce Pty Ltd	PLAN - ADVERTISING - Notification of Approval of Amendment 37 to FTPS Narrogin Observer 05/08/2021	\$ 219.78			
77	EFT17098	09/09/2021	YMCA WA			\$ 240.00	L	
78	INV SI-A010687	31/08/2021	YMCA WA	ADMIN - OCCUPATIONAL HEALTH & SAFETY - 3 Month Gym Membership for Dale Stewart (14/09/2021-13/12/2021)	\$ 240.00			
79	EFT17099	09/09/2021	Conway Highbury Pty Ltd			\$ 350.63	L	
80	INV 591	01/09/2021	Conway Highbury Pty Ltd	OTHGOV - OTHER CONSULTANCY - STATUTORY - Provision of Governance Services January to March 2021	\$ 350.63			
81	EFT17100	09/09/2021	Benara Nurseries			\$ 727.72		
82	INV 315053	20/08/2021	Benara Nurseries	STREET TREE MAINTENANCE - Agonis Flexuosa x3 & Freight	\$ 727.72			
83	EFT17101	09/09/2021	Wild & Waste Free			\$ 77.45	L	F
84	INV 0072	02/09/2021	Wild & Waste Free	CHSP - SOCIAL SUPPORT GROUP OTHER EXPENSES - Cooking Ingredients (Jessie House)	\$ 77.45			
85	EFT17102	09/09/2021	Narrogin Country Fresh Meats			\$ 288.60	L	F
86	INV 1	01/09/2021	Narrogin Country Fresh Meats	CHSP SOCIAL SUPPORT GROUP OTHER EXPENSES - Meat Purchases for August (Jessie House)	\$ 288.60			

	Chq/EFT/DD	Date	Name	Description	Invoice Amount	Payment Total	Type	Funding
87	EFT17103	09/09/2021	Simply Uniforms			\$ 369.99		F
88	INV INV-8542	30/03/2021	Simply Uniforms	CHSP - RECRUITMENT - Stretch Tunic x6, Men's Cargo Pants & Men's Shirt with Logos	\$ 369.99			
89	EFT17104	09/09/2021	Jessica Kennedy Acupuncture			\$ 100.00		F
90	INV 000098	01/09/2021	Jessica Kennedy Acupuncture	CHCP - CLIENT PURCHASES - Acupuncture Appointment	\$ 100.00			
91	EFT17105	09/09/2021	Dulcie Lorraine McGarrigal (Estate of)			\$ 418.01		F
92	INV 160821	16/08/2021	Dulcie Lorraine McGarrigal (Estate of)	CHCP - REFUND OF UNSPENT MONIES - Client Deceased	\$ 418.01			
93	EFT17106	09/09/2021	Jeanette Manning (Estate of)			\$ 1,179.21		F
94	INV 170621	17/06/2021	Jeanette Manning (Estate of)	CHCP - REFUND OF UNSPENT MONIES - Client Deceased	\$ 1,179.21			
95	EFT17107	09/09/2021	Eric Fleay			\$ 613.89		F
96	INV 200221	20/02/2021	Eric Fleay	CHCP - REFUND OF UNSPENT MONIES - Client Moved into Residential Care	\$ 613.89			
97	EFT17108	13/09/2021	Synergy			\$ 12,180.53		
98	INV 649918430	01/09/2021	Synergy	ROADM - STREET LIGHTING MAINTENANCE/OPERATIONS - Electricity Usage (25/07/2021-24/08/2021)	\$ 12,180.53			
99	EFT17109	13/09/2021	Great Southern Fuels			\$ 974.45	L	
100	INV 19007693	31/08/2021	Great Southern Fuels	POC - FUELS AND OILS- 205L Oil For Workshop	\$ 974.45			
101	EFT17110	13/09/2021	Narrogin Fruit Market			\$ 17.20	L	
102	INV 00032021082741	17/08/2021	Narrogin Fruit Market	MEMBERS - CIVIC FUNCTIONS, REFRESHMENTS & RECEPTIONS - Full Cream & Hilo Milk	\$ 8.60			
103	INV 00032021081934	19/08/2021	Narrogin Fruit Market	MEMBERS - CIVIC FUNCTIONS, REFRESHMENTS & RECEPTIONS - Hilo Milk x2	\$ 8.60			
104	EFT17111	13/09/2021	Water Corporation			\$ 757.96		
105	INV Q88KU	08/09/2021	Water Corporation	VARIOUS BUILDINGS - Water Usage (01/09/2021-31/10/2021)	\$ 757.96			
106	EFT17112	13/09/2021	Susan Farrell			\$ 50.00	L	
107	INV 049	11/08/2021	Susan Farrell	MEMBERS - CIVIC FUNCTIONS, REFRESHMENTS & RECEPTIONS - Various Ranges of Laundry	\$ 50.00			
108	EFT17113	13/09/2021	Westrac Pty Ltd			\$ 168.61		
109	INV PI6158211	03/09/2021	Westrac Pty Ltd	NO4141 2010 CATERPILLAR 432E BACKHOE LOADER - Lip Seal x2 (Transmission)	\$ 168.61			

	Chq/EFT/DD	Date	Name	Description	Invoice Amount	Payment Total	Type	Funding
110	EFT17114	13/09/2021	Octave Holdings Pty Ltd T/A Narrogin Toyota			\$ 1,027.65	L	
111	INV PI23048115	03/09/2021	Octave Holdings Pty Ltd T/A Narrogin Toyota	NO01 2019 HOLDEN COLORADO - Seat Covers & Roof Racks	\$ 1,027.65			
112	EFT17115	13/09/2021	Toll Transport Pty Ltd			\$ 196.37		
113	INV 0505-T740710	22/08/2021	Toll Transport Pty Ltd	LYDEKER DEPOT BUILDING OPERATIONS - Freight Charges (18/08/2021 x2)	\$ 196.37			
114	EFT17116	13/09/2021	New Security Installations Pty Ltd			\$ 915.20		F
115	INV 00014342	01/09/2021	New Security Installations Pty Ltd	CHSP - SECURITY SYSTEM - Alarm Monitoring 25/10/2021-24/10/2022 (Jessie House)	\$ 915.20			
116	EFT17117	13/09/2021	WA. Police Strategic Prevention Unit			\$ 33.40		F
117	INV 12708896	31/08/2021	WA. Police Strategic Prevention Unit	CHSP - RECRUITMENT - National Police Check for 2 Volunteers	\$ 33.40			
118	EFT17118	13/09/2021	Belvedere Nursery			\$ 43.70	L	
119	INV I0000001848	02/09/2021	Belvedere Nursery	PARKS & GARDENS MAINTENANCE - Rose Fertiliser, Black Spot Spray & Aphid Spray	\$ 27.90			
120	INV I0000001851	08/09/2021	Belvedere Nursery	CHSP - GENERAL EXPENDITURE - Punnet of Seedlings (Jessie House)	\$ 15.80			
121	EFT17119	13/09/2021	West Australian Newspapers Limited			\$ 660.00		
122	INV 1028037520210831	31/08/2021	West Australian Newspapers Limited	MEMBERS - ADVERTISING & PROMOTIONS - Full Page Newsletter - Narrogin Narrative August 2021	\$ 660.00			
123	EFT17120	13/09/2021	Narrogin Pumps Solar And Spraying			\$ 235.34	L	
124	INV 00036351	26/08/2021	Narrogin Pumps Solar And Spraying	SMALL PLANT - Parts To Repair Spray Unit	\$ 235.34			
125	EFT17121	13/09/2021	Olympics Netball Club			\$ 1,250.00	L	
126	INV 020921	02/09/2021	Olympics Netball Club	OTHFUL - COMMUNITY CHEST - 2019/20	\$ 1,250.00			
127	EFT17122	13/09/2021	Narrogin Senior High School			\$ 70.00	L	
128	INV 300821	30/08/2021	Narrogin Senior High School	MEMBERS - DONATIONS TO COMMUNITY GROUPS - Year 12 Presentations Awards Donation	\$ 70.00			
129	EFT17123	13/09/2021	Carolyn Thompson			\$ 100.00	L	
130	INV 2122_01	07/09/2021	Carolyn Thompson	TOWN HALL (FEDERAL ST) BUILDING OPERATIONS - Coffee Table for Mayors Parlour	\$ 100.00			
131	EFT17124	13/09/2021	YMCA WA			\$ 240.00	L	
132	INV SI-A010686	31/08/2021	YMCA WA	ADMIN - OCCUPATIONAL HEALTH & SAFETY - 3 Month Gym Membership for Victoria Anderson (14/09/2021-13/12/2021)	\$ 240.00			

	Chq/EFT/DD	Date	Name	Description	Invoice Amount	Payment Total	Type	Funding
133	EFT17125	13/09/2021	Easifleet			\$ 2,227.87		
134	INV 310821	31/08/2021	Easifleet	NOVATED LEASES - Employee Expenses	\$ 2,227.87			
135	EFT17126	13/09/2021	BKS Electrical Pty Ltd			\$ 707.96	L	
136	INV 2808	08/09/2021	BKS Electrical Pty Ltd	CAFE 45 FEDERAL ST BUILDING MAINTENACE - Install RCD protection - 3ph Outlet	\$ 707.96			
137	EFT17127	13/09/2021	Great Southern Electrical Services			\$ 6,176.52	L	
138	INV INV-00012045	27/07/2021	Great Southern Electrical Services	CLAYTON OVAL MAINTENANCE/OPERATIONS - Repairs To Lights	\$ 6,176.52			
139	EFT17128	13/09/2021	Sunny Industrial Brushware			\$ 3,715.57		
140	INV 00023853	31/08/2021	Sunny Industrial Brushware	1EUF156 HINO ROAD SWEEPER 2004 - Pallet Of Gutter Brooms	\$ 1,936.00			
141	INV 00023863	01/09/2021	Sunny Industrial Brushware	1EUF156 HINO ROAD SWEEPER 2004 - 9x Main Brooms (Pallet)	\$ 1,779.57			
142	EFT17129	13/09/2021	O'Rourke Electric Services			\$ 345.40	L	F
143	INV INV-1512	07/09/2021	O'Rourke Electric Services	CHCP - CLIENT PURCHASES - Power Outlet to Rear Bedroom	\$ 345.40			
144	EFT17130	13/09/2021	Win Television WA Pty Ltd T/A WIN Television Network			\$ 1,320.00		
145	INV 1141362-2	31/08/2021	Win Television WA Pty Ltd T/A WIN Television Network	MEMBERS ADVERTISING & PROMOTIONS - Shire Promotion on WIN Network August 2021	\$ 1,320.00			
146	EFT17131	13/09/2021	Industrial Automation			\$ 1,332.10		
147	INV SINV-14351	06/09/2021	Industrial Automation	STANDPIPE MAINTENANCE/OPERATIONS - Annual Access & Support Fee	\$ 1,332.10			
148	EFT17132	13/09/2021	Narrogin Fresh			\$ 1,219.60	L	PF
149	INV AUGUST 2021	02/08/2021	Narrogin Fresh	VARIOUS DEPARTMENTS - Narrogin Fresh Account August 2021	\$ 1,219.60			
150	EFT17133	13/09/2021	Surgical House Pty Ltd			\$ 585.78		F
151	INV A765065	09/08/2021	Surgical House Pty Ltd	CHSP GENERAL EXPENDITURE - Various Medical Supplies	\$ 585.78			
152	EFT17134	13/09/2021	Spyker Technologies Pty Ltd T/A Spyker Business Solutions			\$ 2,776.40		
153	INV 2122079	02/09/2021	Spyker Technologies Pty Ltd T/A Spyker Business Solutions	OLOPS - CCTV MAINTENANCE - Cameras & Costs Included	\$ 2,776.40			
154	EFT17135	13/09/2021	Casey Lee Thornton			\$ 1,260.00	L	
155	INV 000017	03/09/2021	Casey Lee Thornton	OTHCUL - ARTWORK COLLECTION - Condition Report & Re-Installation of 3 Shire Art Collections	\$ 1,260.00			

	Chq/EFT/DD	Date	Name	Description	Invoice Amount	Payment Total	Type	Funding
156	EFT17136	13/09/2021	Hersey's Safety			\$ 1,109.06		
157	INV 47186	01/09/2021	Hersey's Safety	VARIOUS DEPARTMENTS - Safety Items. Parks & Gardens Equipment	\$ 1,109.06			
158	EFT17137	13/09/2021	Edwards Isuzu Ute			\$ 810.15	L	
159	INV 41604	29/03/2021	Edwards Isuzu Ute	NGN00 2019 HOLDEN ACADIA LTZ - 48000KM Service	\$ 350.00			
160	INV 42115	08/04/2021	Edwards Isuzu Ute	NGN2 MY20 HOLDEN TRAX LS 1.4L TURBO - 48,000km Service	\$ 460.15			
161	EFT17138	13/09/2021	Integrated ICT			\$ 3,731.42		
162	INV 18875	31/08/2021	Integrated ICT	ADMIN - INFORMATION SYSTEMS - Disaster Recovery Solution as per submission RFQ20/21-08 - Labour Cost for Set Up	\$ 2,695.00			
163	INV 18678	31/08/2021	Integrated ICT	ADMIN - INFORMATION SYSTEMS - 100/40 NBN Internet for 2021-22	\$ 198.00			
164	INV 18734	31/08/2021	Integrated ICT	ADMIN - INFORMATION SYSTEMS - ConnectWise Automate Client & ConnectWise IT License	\$ 651.20			
165	INV 18816	31/08/2021	Integrated ICT	ADMIN - INFORMATION SYSTEMS - M365 Exclaimer Signatures x75	\$ 187.22			
166	EFT17139	13/09/2021	Transport Parts WA			\$ 3,774.65		
167	INV SINV20081	17/08/2021	Transport Parts WA	NO2260 1994 THREE AXLE DOG TRAILER - Brake Drums, Lined Shoe Set, Seals & Bearings	\$ 3,774.65			
168	EFT17140	13/09/2021	Karen Therese Keeley			\$ 3,691.00	L	
169	INV 060921	06/09/2021	Karen Therese Keeley	TOUR - PUBLIC RELATIONS & AREA PROMOTION - OTHCUL - Condition Report & Re-Installation of 3 Shire Art Collections	\$ 3,691.00			
170	PAYROLL 6	13/09/2021	PAYROLL	PAYROLL 6 - PPE 13/09/2021	\$ 152,301.52			
171	EFT17141	16/09/2021	Narrogin Hire & Reticulation			\$ 391.30	L	
172	INV 00031077	07/09/2021	Narrogin Hire & Reticulation	PARKS & GARDENS MAINTENANCE - Orbit Tripod Base	\$ 87.80			
173	INV 00031139	10/09/2021	Narrogin Hire & Reticulation	COM AMEN - BUILDING (CAPITAL) CBD ABULTION UPGRADES - Hire of Portable Toilets x2 for 2 Weeks	\$ 303.50			
174	EFT17142	16/09/2021	Coles			\$ 988.10		PF
175	INV 174	31/08/2021	Coles	VARIOUS DEPARTMENTS - Coles August 2021	\$ 988.10			

	Chq/EFT/DD	Date	Name	Description	Invoice Amount	Payment Total	Type	Funding
176	EFT17143	16/09/2021	Narrogin Packaging			\$ 931.40	L	
177	INV 00071138	04/09/2021	Narrogin Packaging	VARIOUS TOILETS - Cleaning Supplies	\$ 316.75			
178	INV 00071123	07/09/2021	Narrogin Packaging	OTHER PURCHASES FOR CV19 RESPOSE - Hand Sanitiser 5L Refill	\$ 179.00			
179	INV 00071157	08/09/2021	Narrogin Packaging	TOWN HALL (FEDERAL ST) BUILDING MAINTENANCE - Cleaning Supplies	\$ 435.65			
180	EFT17144	16/09/2021	Great Southern Fuels			\$ 5,814.15	L	PF
181	INV 00031307	31/08/2021	Great Southern Fuels	VARIOUS VEHICLES - Fuel Card Charges August 2021	\$ 5,814.15			
182	EFT17145	16/09/2021	Kleenheat Gas			\$ 351.90		
183	INV 4388200	01/09/2021	Kleenheat Gas	TOWN HALL (FEDERAL ST) BUILDING OPERATIONS - Facility Fee / Cylinder Service Charge Year 2021	\$ 140.76			
184	INV 467200	01/09/2021	Kleenheat Gas	NRLC - UTILITY - GAS - Facility Fee/ Cylinder Service Charge Year 2021	\$ 70.38			
185	INV 4388199	01/09/2021	Kleenheat Gas	JOHN HIGGINS COMMUNITY COMPLEX BUILDING OPERATIONS - Facility Fee / Cylinder Service Charge Year 2021	\$ 140.76			
186	EFT17146	16/09/2021	Hancock's Home Hardware			\$ 23.00	L	
187	INV 373858	13/09/2021	Hancock's Home Hardware	MACKIE PARK PUBLIC TOILETS AND OFFICE MAINTENANCE - Storage Cupboard & Faucet Security Keys	\$ 23.00			
188	EFT17147	16/09/2021	Parry's Pty Ltd			\$ 451.55	L	PF
189	INV 57017	03/08/2021	Parry's Pty Ltd	PWO - WORKS - Protective Clothing - Pair Pants x1 (C. Williams)	\$ 67.95			
190	INV 57224	09/08/2021	Parry's Pty Ltd	PWO - EMTRS - ALLOWANCES - Uniforms Jeans x2 (J. Warburton)	\$ 101.90			
191	INV 020100572973	11/08/2021	Parry's Pty Ltd	CHCP - CLIENT PURCHASES - Van Black Shoes x1	\$ 104.95			
192	INV 57842	26/08/2021	Parry's Pty Ltd	PWO - WORKS - PROTECTIVE CLOTHING - Work Boots (J. Warburton)	\$ 135.95			
193	INV 58025	30/08/2021	Parry's Pty Ltd	HEALTH - TRAIING & DEVELOPMENT - Hi-Viz Vests x4	\$ 40.80			
194	EFT17148	16/09/2021	Narrogin Earthmoving & Concrete Pty Ltd Atf The Mcnab Family Trust			\$ 2,750.00	L	PF
195	INV IV00000001341	07/09/2021	Narrogin Earthmoving & Concrete Pty Ltd Atf The Mcnab Family Trust	RAILWAY STATION RESTORATION COVID RECOVERY PROJECT - Gravel Works to Train Station Platform	\$ 2,750.00			
196	EFT17149	16/09/2021	Department of Fire & Emergency Services (DFES)			\$ 84,523.37		
197	INV 152566	23/08/2021	Department of Fire & Emergency Services (DFES)	FESA ESL LIABILITY - ESL Quarter 1 2021/22	\$ 84,523.37			

	Chq/EFT/DD	Date	Name	Description	Invoice Amount	Payment Total	Type	Funding
198	EFT17150	16/09/2021	Narrogin Meals On Wheels			\$ 515.12	L	F
199	INV 101078	06/08/2021	Narrogin Meals On Wheels	CHSP MEALS ON WHEELS COMMITTEE - Meal Delivery Service July 2021	\$ 515.12			
200	EFT17151	16/09/2021	Narrogin Newsagency			\$ 98.55	L	
201	INV 1355-285683	01/09/2021	Narrogin Newsagency	LIB - SUSCRIPTIONS & MEMBERSHIPS - Deliveries for the Period 14/08/2021-28/08/2021 & Newspapers	\$ 98.55			
202	EFT17152	16/09/2021	Narrogin Liquor Barons			\$ 374.97	L	
203	INV 192499	31/08/2021	Narrogin Liquor Barons	MEMBERS - CIVIC FUNCTIONS, REFRESHMENTS & RECEPTIONS - Refreshments for Councillors & Civic Functions	\$ 374.97			
204	EFT17153	16/09/2021	Narrogin Betta Home Living			\$ 599.00	L	
205	INV 25710040347	10/09/2021	Narrogin Betta Home Living	TOWN HALL (FEDERAL ST) BUILDING MAINTENANCE - Miele Vacuum for Mayors Parlour	\$ 599.00			
206	EFT17154	16/09/2021	Great Southern Waste Disposal			\$ 40,832.92		
207	INV IV00000001708	10/09/2021	Great Southern Waste Disposal	BIN COLLECTIONS VARIOUS LOCATIONS - August 2021	\$ 40,832.92			
208	EFT17155	16/09/2021	Public Transport Authority			\$ 616.93		
209	INV 310821	31/08/2021	Public Transport Authority	TRANSWA - AGENT LIABILITY - Trans WA Ticket Sales August 2021	\$ 616.93			
210	EFT17156	16/09/2021	Air Response			\$ 178.75	L	
211	INV 15079.9A	08/09/2021	Air Response	ADMIN OFFICE BUILDING MAINTENANCE - Air Con Quarterly Maintenance Check	\$ 178.75			
212	EFT17157	16/09/2021	Narrogin Panel Beating Service			\$ 750.00	L	
213	INV 8494	09/09/2021	Narrogin Panel Beating Service	ONO 2020 HOLDEN TRAILBLAZER LTZ - Insurance Excess	\$ 750.00			
214	EFT17158	16/09/2021	Shire Of Narrogin			\$ 126.22	L	
215	INV 310821	31/08/2021	Shire Of Narrogin	TRANSWA - AGENT LIABILITY - Commission August 2021 Ticket Sales	\$ 126.22			
216	EFT17159	16/09/2021	Narrogin Removals & Storage			\$ 3,180.00	L	
217	INV 2482	11/09/2021	Narrogin Removals & Storage	ADMIN - RECORDS MANAGEMENT - Rent for Storage Unit 17/12/2020 - 17/12/2021	\$ 3,180.00			
218	EFT17160	16/09/2021	Signs Plus			\$ 109.50		PF
219	INV 00166871	05/08/2021	Signs Plus	CHSP - RECRUITMENT - Names Badges x3 & Freight	\$ 48.00			
220	INV 00167318	26/08/2021	Signs Plus	ADMIN - PRINTING & STATIONERY - Name Badges x 4 & Freight	\$ 61.50			

	Chq/EFT/DD	Date	Name	Description	Invoice Amount	Payment Total	Type	Funding
221	EFT17161	16/09/2021	A & A Corasaniti Building Contractors Pty Ltd			\$ 165.00	L	
222	INV 210	13/09/2021	A & A Corasaniti Building Contractors Pty Ltd	CAFE 45 FEDERAL ST BUILDING MAINTENANCE - Water Leak Repairs Inside Cafe & Upstairs Apartment	\$ 165.00			
223	EFT17162	16/09/2021	Melchiorre Plumbing & Gas			\$ 6,014.95	L	
224	INV 200	06/08/2021	Melchiorre Plumbing & Gas	CARAVAN PARK - RENEWAL DEVELOPMENT - Install New Water Line in Conjunction with Sewer Works	\$ 5,726.86			
225	INV 217	09/09/2021	Melchiorre Plumbing & Gas	CARAVAN PARK GENERAL MAINTENANCE/OPERATIONS - Fix Leak, Replace Ball Valve & New Retic Box	\$ 288.09			
226	EFT17163	16/09/2021	Belvedere Nursery			\$ 333.50	L	
227	INV I0000001853	11/09/2021	Belvedere Nursery	MEMBERS - CIVIC SUNCTIONS, REFRESHMENTS & RECEPTIONS - Australian Citizenship Gifts for Australian Citizenship Day	\$ 333.50			
228	EFT17164	16/09/2021	Holy Cow Creations			\$ 120.00		
229	INV 029	09/09/2021	Holy Cow Creations	RATES - PRINTING AND STATIONERY - Graphic Design Services for 2021-22 Ratepayer Information Brochures	\$ 120.00			
230	EFT17165	16/09/2021	YMCA WA			\$ 31,766.63	L	
231	INV SI-A010685	31/08/2021	YMCA WA	ADMIN - OCCUPATIONAL HEALTH & SAFETY - 3 Month Gym Membership for Alex Mulenga (30/08/2021-29/11/2021)	\$ 168.99			
232	INV SI-A010704	31/08/2021	YMCA WA	NRLC - CONTRACT MANAGEMENT EXPENSE - YMCA Management Fee August 2021 & Actual Deficit for August 2021	\$ 31,597.64			
233	EFT17166	16/09/2021	Easifleet			\$ 2,227.87		
234	INV 150921	15/09/2021	Easifleet	NOVATED LEASES - Employee Expenses	\$ 2,227.87			
235	EFT17167	16/09/2021	Azhar Awang			\$ 581.90	L	
236	INV 130921	13/09/2021	Azhar Awang	SAN - TRAINING & DEVELOPMENT - Waste Conference Accommodation 07/09/2021-10/09/2021	\$ 581.90			
237	EFT17168	16/09/2021	Major Motors Pty Ltd			\$ 885.64		
238	INV 1098576	09/09/2021	Major Motors Pty Ltd	NO5020 & NO209 FIRE UNIT - Filters For Service	\$ 885.64			
239	EFT17169	16/09/2021	E & Mj Rosher Pty Ltd			\$ 141.39		
240	INV 1432913	06/09/2021	E & Mj Rosher Pty Ltd	NO2768 2013 SEWELL TB2000E ROAD SWEEPER - Service Kit	\$ 141.39			
241	EFT17170	16/09/2021	Narrogin Skip Bin Service			\$ 159.50	L	
242	INV INV-1116	31/08/2021	Narrogin Skip Bin Service	LYDEKER DEPOT BUILDING MAINTENANCE - Skip Bin Pickup 05/08/2021	\$ 159.50			

	Chq/EFT/DD	Date	Name	Description	Invoice Amount	Payment Total	Type	Funding
243	EFT17171	16/09/2021	Telair Pty Ltd			\$ 1,420.00		PF
244	INV TA10781-026	31/08/2021	Telair Pty Ltd	VARIOUS DEPARTMENTS - Telephone Charges August 2021	\$ 1,420.00			
245	EFT17172	16/09/2021	Epic Fire Solutions T/As MCG Fire Services			\$ 1,255.10	L	
246	INV INV-1580	10/09/2021	Epic Fire Solutions T/As MCG Fire Services	NRLC - PLANT EQUIPMENT OTHER (CAPITAL) - Light Protection Cages for Emergency Exits x 5	\$ 1,255.10			
247	EFT17173	16/09/2021	Divine's Coffee Cups			\$ 450.00	L	
248	INV INV-00015	08/09/2021	Divine's Coffee Cups	MEMBERS- CIVIC FUNCTIONS, REFRESHMENTS & RECEPTIONS - Catering for MBS Meeting 8/09/2021	\$ 450.00			
249	EFT17174	16/09/2021	Paget Marie Elliott			\$ 331.20		
250	INV 150921	15/09/2021	Paget Marie Elliott	RATES REFUNDS SUSPESE A/C - Refund of Rates Paid in Error to A565 - 360 Parks Road, Highbury	\$ 331.20			
251	EFT17175	17/09/2021	Department Of Human Services			\$ 483.23		
252	INV DEDUCTION	30/08/2021	Department Of Human Services	Payroll deductions	\$ 244.70			
253	INV DEDUCTION	13/09/2021	Department Of Human Services	Payroll deductions	\$ 238.53			
254	EFT17176	17/09/2021	Local Government Racing & Cemeteries Employees Union (LGREU)			\$ 41.00		
255	INV DEDUCTION	30/08/2021	Local Government Racing & Cemeteries Employees Union (LGREU)	Payroll deductions	\$ 20.50			
256	INV DEDUCTION	13/09/2021	Local Government Racing & Cemeteries Employees Union (LGREU)	Payroll deductions	\$ 20.50			
257	EFT17177	17/09/2021	Australian Services Union Western Australian Branch			\$ 51.80		
258	INV DEDUCTION	30/08/2021	Australian Services Union Western Australian Branch	Payroll deductions	\$ 25.90			
259	INV DEDUCTION	13/09/2021	Australian Services Union Western Australian Branch	Payroll deductions	\$ 25.90			
260	EFT17178	17/09/2021	Narrogin Hire & Reticulation			\$ 110.00	L	
261	INV 00031138	02/09/2021	Narrogin Hire & Reticulation	NGN13362 2016 TRAILER - Trailer Hire for Homecare Maintenance	\$ 110.00			
262	EFT17179	17/09/2021	Total Undercar			\$ 789.00	L	
263	INV M1112	18/03/2021	Total Undercar	NGN15333 2014 MAZDA BT-50 - New Tyres x 4 & Fitting	\$ 789.00			

	Chq/EFT/DD	Date	Name	Description	Invoice Amount	Payment Total	Type	Funding
264	EFT17180	17/09/2021	Kleenheat Gas			\$ 15,808.57		
265	INV 2723717	13/09/2021	Kleenheat Gas	CARAVAN PARK GENERAL MAINTENANCE/OPERATIONS - Electricity Usage (01/08/2021-31/08/2021)	\$ 1,734.97			
266	INV 2723745	13/09/2021	Kleenheat Gas	NRLC - UTILITY - ELECTRICITY - Electricity Usage (01/08/2021-31/08/2021)	\$ 13,333.33			
267	INV 2723727	13/09/2021	Kleenheat Gas	ADMIN OFFICE BUILDING OPERATIONS - Electricity Usage (01/08/2021-31/08/2021)	\$ 740.27			
268	EFT17181	17/09/2021	Susan Farrell			\$ 100.00	L	
269	INV 051	25/08/2021	Susan Farrell	MEMBERS - CIVIC FUNCTIONS, REFRESHMENTS & RECEPTIONS - Various Range of Laundry	\$ 50.00			
270	INV 052	08/09/2021	Susan Farrell	MEMBERS - CIVIC FUNCTIONS, REFRESHMENTS & RECEPTIONS - Various Range of Laundry	\$ 50.00			
271	EFT17182	17/09/2021	Geoff Perkins Farm Machinery Centre			\$ 57.27	L	
272	INV 102434	08/09/2021	Geoff Perkins Farm Machinery Centre	SMALL PLANT - HOMECARE - Whipper Snipper Line x2	\$ 57.27			
273	EFT17183	17/09/2021	Narrogin Newsagency			\$ 33.70	L	F
274	INV 1245-285633	01/09/2021	Narrogin Newsagency	CHSP SOCIAL SUPPORT GROUP OTHER EXPENSES - Deliveries for the Period 03/08/2021-31/08/2021 & Newspapers	\$ 33.70			
275	EFT17184	17/09/2021	RJ Smith Engineering			\$ 241.75	L	
276	INV 00015616	10/09/2021	RJ Smith Engineering	2017 JOHN DEERE RIDE ON MOWER - Steel Plate	\$ 30.00			
277	INV 00015727	14/09/2021	RJ Smith Engineering	VARIOUS DEPARTMENTS - One Box Grease 12 Cartridges & One Box Wurth Gloves	\$ 211.75			
278	EFT17185	17/09/2021	Narrogin Panel Beating Service			\$ 380.96	L	F
279	INV 8497	16/09/2021	Narrogin Panel Beating Service	CHSP - GENERAL EXPENDITURE - Supply & Install R/H Rear Door Glass	\$ 380.96			
280	EFT17186	17/09/2021	Shire Of Narrogin			\$ 445.54	L	
281	INV A226650	08/09/2021	Shire Of Narrogin	COMMUNITY GARDEN MAINTENANCE/OPERATIONS - Rubbish Collection Services Fee 2021/22 (Lot 1721 Hale Street)	\$ 357.00			
282	INV A233	08/09/2021	Shire Of Narrogin	FIRE - ESL PAYABLE ON SHIRE BUILDINGS - ESL Charges 2021/22 (Lot 45 Forrest Street)	\$ 88.54			
283	EFT17187	17/09/2021	Bladon WA			\$ 561.00		
284	INV BWA149093	10/09/2021	Bladon WA	MEMBERS - PRINTING & STATIONERY - Printing & Production of 100 Mouse Mats (Shire Values)	\$ 561.00			
285	EFT17188	17/09/2021	Allmark			\$ 940.50		
286	INV IN0032580	13/09/2021	Allmark	OTHERCUL - FESTIVAL & EVENTS - Promotional Material - Shire of Narrogin Badged Retractable Banners x 4	\$ 940.50			

	Chq/EFT/DD	Date	Name	Description	Invoice Amount	Payment Total	Type	Funding
287	EFT17189	17/09/2021	Jcb Construction Equipment Australia			\$ 187.78		
288	INV 127181P	13/09/2021	Jcb Construction Equipment Australia	2019 JCB 5CX BACKHOE LOADER - One Light Rear Combine	\$ 187.78			
289	EFT17190	17/09/2021	Narrogin Auto Centre			\$ 316.40	L	
290	INV 304692	13/09/2021	Narrogin Auto Centre	00NGN 2018 NISSAN NAVARA - Filters For Service	\$ 316.40			
291	EFT17191	17/09/2021	Wild & Waste Free			\$ 60.00	L	
292	INV 0076	09/09/2021	Wild & Waste Free	MEMBERS - CIVIC FUNCTIONS, REFRESHMENTS & RECEPTIONS - Gifts to New Businesses to Town	\$ 60.00			
293	EFT17192	17/09/2021	Farmworks Narrogin Pty Ltd			\$ 8,558.00	L	PF
294	INV 88588	13/09/2021	Farmworks Narrogin Pty Ltd	VERGE MAINTENANCE - Kelpie Rico 450 Glyphosate 1000Lts	\$ 8,360.00			
295	INV 88595	13/09/2021	Farmworks Narrogin Pty Ltd	WAGIN-WIKEPIN ROAD - RENEWAL (Rural) (RRG) - Survey Markers	\$ 198.00			
296	EFT17193	17/09/2021	Johns Building Supplies			\$ 2,885.45		PF
297	INV 987853	13/09/2021	Johns Building Supplies	RAILWAY STATION RESTORATION COVID RECOVERY PROJECT - 5 New External Doors	\$ 2,885.45			
298	EFT17194	17/09/2021	Astrotourism WA Pty Ltd			\$ 4,400.00		
299	INV 1079	08/07/2021	Astrotourism WA Pty Ltd	TOUR - PUBLIC RELATIONS & AREA PROMOTION - Astrotourism Town Establishment Year 2 (2021/22)	\$ 4,400.00			
300	EFT17195	17/09/2021	Jessica Kennedy Acupuncture			\$ 100.00		F
301	INV 000107	14/09/2021	Jessica Kennedy Acupuncture	CHCP - CLIENT PURCHASES - Standard Acupuncture Consultation	\$ 100.00			
302	EFT17196	17/09/2021	Bossea Pty Ltd			\$ 254.00		
303	INV INV-4479	30/06/2021	Bossea Pty Ltd	ADMIN - OFFICE EQUIPMENT MTCE - Collection & Delivery of Blue Confidential Bin for Destruction	\$ 88.00			
304	INV INV-4736	12/07/2021	Bossea Pty Ltd	ADMIN - OFFICE EQUIPMENT MTCE - Security Bin Annual Rental (01/07/2021 - 30/06/2022)	\$ 78.00			
305	INV INV-4935	27/08/2021	Bossea Pty Ltd	ADMIN - OFFICE EQUIPMENT MTCE - Collection & Delivery of Blue Confidential Bin for Destruction	\$ 88.00			
306	EFT17197	23/09/2021	Best Office Systems			\$ 997.00	L	
307	INV 592479	09/09/2021	Best Office Systems	ADMIN - PRINTING & STATIONERY - Traffic Licensing Printer Toner x2	\$ 418.00			
308	INV 592477	09/09/2021	Best Office Systems	ADMIN - PRINTING & STATIONERY - Black Toner x2	\$ 370.00			
309	INV 592478	09/09/2021	Best Office Systems	CARAVAN PARK GENERAL MAINTENANCE/OPERATIONS - Black Toner x1	\$ 209.00			

	Chq/EFT/DD	Date	Name	Description	Invoice Amount	Payment Total	Type	Funding
310	EFT17198	23/09/2021	Synergy			\$ 1,012.46		
311	INV 2001372074	20/09/2021	Synergy	JOHN HIGGINS COMMUNITY COMPLEX BUILDING OPERATIONS - Electricity Usage (16/08/2021-13/09/2021)	\$ 1,012.46			
312	EFT17199	23/09/2021	Narrogin Packaging			\$ 553.60	L	
313	INV 00071273	10/09/2021	Narrogin Packaging	HIGHBURY PUBLIC TOILETS OPERATIONS - Cleaning Supplies	\$ 101.50			
314	INV 00071298	14/09/2021	Narrogin Packaging	CARAVAN PARK GENERAL MAINTENANCE/OPERATIONS - Cleaning Supplies	\$ 54.90			
315	INV 00071328	18/09/2021	Narrogin Packaging	VARIOUS TOILETS - Cleaning Supplies	\$ 339.20			
316	INV 00071332	20/09/2021	Narrogin Packaging	MEMORIAL PARK TOILETS MAINTENANCE - New Industrial Mop Bucket for Cleaners	\$ 58.00			
317	EFT17200	23/09/2021	Australia Post			\$ 408.18		PF
318	INV 623446	17/09/2021	Australia Post	VARIOUS DEPARTMENTS - Postal Charges August 2021	\$ 408.18			
319	EFT17201	23/09/2021	Kleenheat Gas			\$ 15,102.25		
320	INV 2723717	12/08/2021	Kleenheat Gas	CARAVAN PARK GENERAL MAINTENANCE/OPERATIONS - Electricity Usage (01/07/2021-31/07/2021)	\$ 2,020.57			
321	INV 2723727	12/08/2021	Kleenheat Gas	ADMIN OFFICE BUILDING OPERATIONS - Electricity Usage (01/07/2021-31/07/2021)	\$ 815.27			
322	INV 2723745	12/08/2021	Kleenheat Gas	NRLC - UTILITY - ELECTRICITY - Electricity Usage (01/07/2021-31/07/2021)	\$ 12,266.41			
323	EFT17202	23/09/2021	Hancock's Home Hardware			\$ 83.47	L	F
324	INV 374287	17/09/2021	Hancock's Home Hardware	CHSP HOME MAINTENANCE OTHER EXPENSES - Various Items for Trailer	\$ 83.47			
325	EFT17203	23/09/2021	Parry's Pty Ltd			\$ 109.95	L	F
326	INV 57296	11/08/2021	Parry's Pty Ltd	CHCP - CLIENT PURCHASES - Unisex Slippers - Wallaby x1	\$ 109.95			
327	EFT17204	23/09/2021	Geoff Perkins Farm Machinery Centre			\$ 379.00	L	
328	INV 5921	16/09/2021	Geoff Perkins Farm Machinery Centre	SMALL PLANT - New Honda Bent Trimmer	\$ 379.00			
329	EFT17205	23/09/2021	Narrogin Newsagency			\$ 942.14	L	PF
330	INV 286018	14/09/2021	Narrogin Newsagency	ADMIN & CHSP - PRINTING & STATIONERY - Stationery Order September 2021	\$ 826.07			
331	INV 286061	16/09/2021	Narrogin Newsagency	ADMIN - PRINTING & STATIONERY - Stationery Order September 2021	\$ 116.07			

	Chq/EFT/DD	Date	Name	Description	Invoice Amount	Payment Total	Type	Funding
332	EFT17206	23/09/2021	S. Williams Plumbing			\$ 150.00	L	
333	INV 340	14/09/2021	S. Williams Plumbing	MEMORIAL PARK TOILETS MAINTENANCE - Clear Drain & Replace Reflux Valve	\$ 150.00			
334	EFT17207	23/09/2021	RJ Smith Engineering			\$ 3.08	L	
335	INV 00015828	21/09/2021	RJ Smith Engineering	1EUF156 HINO ROAD SWEEPER 2004 - bolts x4 & washers x4	\$ 3.08			
336	EFT17208	23/09/2021	Octave Holdings Pty Ltd T/A Narrogin Toyota			\$ 264.00	L	
337	INV PI23048369	16/09/2021	Octave Holdings Pty Ltd T/A Narrogin Toyota	SMALL PLANT - New Stihl Blower x1	\$ 264.00			
338	EFT17209	23/09/2021	Bucher Municipal Pty Ltd - McDonald Johnston			\$ 1,852.87		
339	INV 1013621	14/09/2021	Bucher Municipal Pty Ltd - McDonald Johnston	1EUF156 HINO ROAD SWEEPER 2004 - Turret	\$ 1,852.87			
340	EFT17210	23/09/2021	Toll Transport Pty Ltd			\$ 35.46		
341	INV 0506-T7407010	06/09/2021	Toll Transport Pty Ltd	LYDEKER DEPOT BUILDING OPERATIONS & HEALTH - ANALYTICAL EXPENSES - Freight Charges (20/08/2021 - 26/08/2021)	\$ 35.46			
342	EFT17211	23/09/2021	Shire Of Narrogin			\$ 4,578.97	L	PF
343	INV A319600	08/09/2021	Shire Of Narrogin	30 GRAY ST BUILDING OPERATIONS (FORMALLY EAST NARROGIN OFFSITE KINDERGARTEN) - ESL & Rubbish Collection Charges 2021/22	\$ 796.00			
344	INV A105196	08/09/2021	Shire Of Narrogin	CHCP - BUILDING RATES - Rubbish Collection Service Fees 2021/22 (30 Clayton Road)	\$ 3,782.97			
345	EFT17212	23/09/2021	Melchiorre Plumbing & Gas			\$ 501.60	L	
346	INV 244	21/09/2021	Melchiorre Plumbing & Gas	CARAVAN PARK GENERAL MAINTENANCE/OPERATIONS - Plumbing Repairs	\$ 501.60			
347	EFT17213	23/09/2021	Gd & Ja Stevens			\$ 414.00	L	
348	INV 1411	16/09/2021	Gd & Ja Stevens	TOWN HALL (FEDERAL ST) BUILDING MAINTENANCE - New Ceiling Panels for Mayors Parlour	\$ 414.00			
349	EFT17214	23/09/2021	Narrogin Tyre Service			\$ 660.00	L	
350	INV 14480	15/09/2021	Narrogin Tyre Service	NO0 2017 MITSUBISHI TRITON - Supply & Fit Tyres x4	\$ 660.00			
351	EFT17215	23/09/2021	Thing-a-me-bobs			\$ 1,200.00	L	
352	INV 1044	16/09/2021	Thing-a-me-bobs	MEMBERS CIVIC FUNCTIONS, REFRESHMENTS & RECEPTIONS - Permanent Floral Arrangements for Civic Ceremonies & Events	\$ 1,200.00			
353	EFT17216	23/09/2021	Aussie Fencing			\$ 9,915.00		PF
354	INV 79264	01/09/2021	Aussie Fencing	RAILWAY STATION RESTORATION COVID RECOVERY PROJECT - Aluminium Level Spear Pool Panels & Freight	\$ 9,915.00			

	Chq/EFT/DD	Date	Name	Description	Invoice Amount	Payment Total	Type	Funding
355	EFT17217	23/09/2021	Edwards Isuzu Ute			\$ 284.57	L	
356	INV R44084	14/09/2021	Edwards Isuzu Ute	032NGN MAZDA CX3 MAXX SPORT - 30,000 KM Service	\$ 284.57			
357	EFT17218	23/09/2021	Kaata-Koorliny Employment & Enterprise Development Aboriginal Corp (KEEDAC)			\$ 259.50	L	
358	INV 150921	15/09/2021	Kaata-Koorliny Employment & Enterprise Development Aboriginal Corp (KEEDAC)	OTHCUL - NAIDOC - Catering Afternoon Tea for NAIDOC	\$ 259.50			
359	EFT17219	23/09/2021	Richard Ockerse			\$ 240.00	L	
360	INV 210921	21/09/2021	Richard Ockerse	ADMIN - RECRUITMENT - Police Clearance, Pre Employment Medical, Drug & Alcohol Screening	\$ 240.00			
361	PAYROLL 7	27/09/2021	PAYROLL	PAYROLL 7 - PPE 27/09/2021	\$ 160,036.94			
362	EFT17220	30/09/2021	Narrogin Hire & Reticulation			\$ 26.64	L	
363	INV 00031174	14/09/2021	Narrogin Hire & Reticulation	PARKS & GARDENS MAINTENANCE - Reticulation Materials	\$ 26.64			
364	EFT17221	30/09/2021	Best Office Systems			\$ 2,608.49	L	PF
365	INV 592843	22/09/2021	Best Office Systems	VARIOUS DEPARTMENTS - Photocopier Charges (20/08/2021-20/09/2021)	\$ 2,608.49			
366	EFT17222	30/09/2021	Great Southern Fuels			\$ 22,473.08	L	
367	INV B32812-D2078916	23/09/2021	Great Southern Fuels	POC - FUELS AND OILS - 16,000L Diesel	\$ 22,473.08			
368	EFT17223	30/09/2021	Water Corporation			\$ 1,589.44		
369	INV Y3AAB	03/08/2021	Water Corporation	VARIOUS BUILDINGS - Water Usage (04/06/2021-02/08/2021)	\$ 1,589.44			
370	EFT17224	30/09/2021	Narrogin Electrical Services			\$ 1,870.00	L	
371	INV 2502	21/09/2021	Narrogin Electrical Services	LIBRARY BUILDING MAINTENANCE - Supply & Install Dome Cameras x16	\$ 1,870.00			
372	EFT17225	30/09/2021	Bucher Municipal Pty Ltd - McDonald Johnston			\$ 830.96		
373	INV 1014477	23/09/2021	Bucher Municipal Pty Ltd - McDonald Johnston	NGN830 2017 FUSO FIGHTER 8T TIP TRUCK - Rubber Kit For Nozzle	\$ 415.48			
374	INV 1014476	23/09/2021	Bucher Municipal Pty Ltd - McDonald Johnston	1EUF156 HINO ROAD SWEEPER 2004 - Rubber Kit For Snorkel	\$ 415.48			
375	EFT17226	30/09/2021	Guy Maley			\$ 267.00	L	
376	INV 230921	23/09/2021	Guy Maley	ANIMAL - EXPENSES MINOR ASSET PURCHASES, TRAINING & DEVELOPMENT - Accommodation x3 Nights & Life proof Phone Cover	\$ 267.00			

	Chq/EFT/DD	Date	Name	Description	Invoice Amount	Payment Total	Type	Funding
377	EFT17227	30/09/2021	Toll Transport Pty Ltd			\$ 95.17		
378	INV 0507-T740710	12/09/2021	Toll Transport Pty Ltd	LYDEKER DEPOT BUILDING OPERATIONS - Freight Charges (03/09/2021-09/09/2021)	\$ 95.17			
379	EFT17228	30/09/2021	Melchiorre Plumbing & Gas			\$ 887.59	L	F
380	INV 229	21/09/2021	Melchiorre Plumbing & Gas	CHSP - GENERAL EXPENDITURE - Supply & Install Wall Mounted Basin & Replace Kitchen Filter (Jessie House)	\$ 887.59			
381	EFT17229	30/09/2021	Western Power			\$ 2,249.00		
382	INV CORPB0570812	22/09/2021	Western Power	CEMETERY UPGRADE - Cemetery Power Connection (152 Williams Road)	\$ 2,249.00			
383	EFT17230	30/09/2021	Easifleet			\$ 2,227.87		
384	INV 230921	23/09/2021	Easifleet	NOVATED LEASES - Employee Expenses PPE 13/09/2021	\$ 2,227.87			
385	EFT17231	30/09/2021	Cemeteries & Crematoria Association Of Western Aus			\$ 125.00		
386	INV 240921	24/09/2021	Cemeteries & Crematoria Association Of Western Aus	ADMIN - SUBSCRIPTIONS AND MEMBERSHIPS - Annual Membership Renewal 2021/22	\$ 125.00			
387	EFT17232	30/09/2021	Lotex Filter Cleaning Service			\$ 239.15		
388	INV 00007286	05/08/2021	Lotex Filter Cleaning Service	POC - PARTS & REPAIRS - August Filter Cleaning	\$ 239.15			
389	EFT17233	30/09/2021	Major Motors Pty Ltd			\$ 707.88		
390	INV 1103507	21/09/2021	Major Motors Pty Ltd	NO5020 ISUZU FTS800 FIRE UNIT - Parts to Repair A/C	\$ 707.88			
391	EFT17234	30/09/2021	Corsign (WA) Pty Ltd			\$ 215.60		
392	INV 00058582	26/07/2021	Corsign (WA) Pty Ltd	CEMETERY UPGRADE - Government Grant Signage	\$ 215.60			
393	EFT17235	30/09/2021	Narrogin Skip Bin Service			\$ 620.40	L	
394	INV INV-1141	31/08/2021	Narrogin Skip Bin Service	LYDEKER DEPOT BUILDING MAINTENANCE - Annual Bin Rental 2020/2021	\$ 620.40			
395	EFT17236	30/09/2021	Safetycare Australia Pty Ltd			\$ 1,320.00		
396	INV 240921	24/09/2021	Safetycare Australia Pty Ltd	ADMIN - OCCUPATIONAL HEALTH & SAFETY - OSH Workplace Training & Assessment System Annual Subscription	\$ 1,320.00			
397	EFT17237	30/09/2021	Narrogin Fresh			\$ 841.02	L	PF
398	INV SEPTEMBER (2) 2021	28/09/2021	Narrogin Fresh	VARIOUS DEPARTMENTS - Narrogin Fresh Account September 2021	\$ 357.43			
399	INV SEPTEMBER 2021	29/09/2021	Narrogin Fresh	VARIOUS DEPARTMENTS - Narrogin Fresh Accounts September 2021	\$ 483.59			

	Chq/EFT/DD	Date	Name	Description	Invoice Amount	Payment Total	Type	Funding
400	EFT17238	30/09/2021	Narrogin Florist			\$ 100.00	L	
401	INV INV255	23/09/2021	Narrogin Florist	MEMBERS - CIVIC FUNCTIONS, REFRESHMENTS & RECEPTIONS - Flowers of Condolence to Vicki on Passing of Former Shire President Richard Chadwick	\$ 100.00			
402	EFT17239	30/09/2021	Surgical House Pty Ltd			\$ 318.92		F
403	INV A771856	24/09/2021	Surgical House Pty Ltd	CHCP - CLIENT PURCHASES - Various Medical Supplier & Freight	\$ 318.92			
404	EFT17240	30/09/2021	Integrated ICT			\$ 2,433.97		
405	INV 18902	31/08/2021	Integrated ICT	ADMIN - INFORMATION SYSTEMS - Antivirus 73 Units Coverage (1/09/2021 - 31/08/2022)	\$ 2,433.97			
406	EFT17241	30/09/2021	ITR Pacific Pty Ltd			\$ 8,214.17		
407	INV 449100	26/07/2021	ITR Pacific Pty Ltd	NO4719 2012 JOHN DEERE 670G GRADER & NO4871 2014 JOHN DEERE 670G GRADER - 50 Grader blades & 25 Scarifier Tips	\$ 8,111.34			
408	INV 449100A	28/07/2021	ITR Pacific Pty Ltd	NO4871 2014 JOHN DEERE 670G GRADER w/ TOP CON - 10 Scarifier Tips	\$ 102.83			
409	EFT17242	30/09/2021	GK Creative Pty Ltd			\$ 199.00		
410	INV GKC2022002	17/09/2021	GK Creative Pty Ltd	SANOTH - WASTE DISPOSAL - Please Slow Down Consider Our Kids Stickers	\$ 199.00			
EFT Total \$					756,678.48			

Chq/EFT/DD	Date	Name	Description	Invoice Amount	Payment Total	Type	Funding
Direct Debits							
411	DD6850.1	01/09/2021	Elgas		\$ 8,428.55		
412	INV 0360884358	26/08/2021	Elgas	NRLC - UTILITY - GAS - Gas Supplied 7,600.0L	\$ 8,428.55		
413	DD6866.1	08/09/2021	Elgas	LYDEKER DEPOT BUILDING OPERATIONS - Gas Supplied 15.0 KG x 3	\$ 174.24		
414	INV 1610702319	01/09/2021	Elgas	LYDEKER DEPOT BUILDING OPERATIONS - Gas Supplied 15.0 KG x 3	\$ 174.24		
415	DD6871.1	07/09/2021	Keenan & Tania Wenning		\$ 1,386.67		
416	INV EMDRS SEPT 2021	03/09/2021	Keenan & Tania Wenning	EMDRS STAFF HOUSING RENTAL PROPERTY EXPENSES - Rent September 2021	\$ 1,386.67		
417	DD6878.1	14/09/2021	Elgas		\$ 8,090.28		
418	INV 0360884223	08/09/2021	Elgas	CARAVAN PARK GENERAL MAINTENANCE/OPERATIONS - Gas Supplied 157.0L	\$ 176.42		
419	INV 0360884224	08/09/2021	Elgas	NRLC - UTILITY - GAS - Gas Supplied 7,043.0L	\$ 7,913.86		
420	DD6882.1	13/09/2021	Aware Super		\$ 14,505.18		
421	INV SUPER	13/09/2021	Aware Super	Superannuation contributions	\$ 12,333.69		
422	INV DEDUCTION	13/09/2021	Aware Super	Payroll deductions	\$ 260.00		
423	INV DEDUCTION	13/09/2021	Aware Super	Payroll deductions	\$ 150.00		
424	INV DEDUCTION	13/09/2021	Aware Super	Payroll deductions	\$ 188.19		
425	INV DEDUCTION	13/09/2021	Aware Super	Payroll deductions	\$ 348.99		
426	INV DEDUCTION	13/09/2021	Aware Super	Payroll deductions	\$ 836.39		
427	INV DEDUCTION	13/09/2021	Aware Super	Payroll deductions	\$ 387.92		
428	DD6882.2	13/09/2021	Spirit Super		\$ 480.05		
429	INV SUPER	13/09/2021	Spirit Super	Superannuation contributions	\$ 360.04		
430	INV DEDUCTION	13/09/2021	Spirit Super	Payroll deductions	\$ 120.01		
431	DD6882.3	13/09/2021	Prime Super		\$ 643.63		
432	INV SUPER	13/09/2021	Prime Super	Superannuation contributions	\$ 643.63		

Chq/EFT/DD	Date	Name	Description	Invoice Amount	Payment Total	Type	Funding
433	DD6882.4	13/09/2021	Lgia Super		\$ 993.91		
434	INV SUPER	13/09/2021	Lgia Super	Superannuation contributions	\$ 507.74		
435	INV DEDUCTION	13/09/2021	Lgia Super	Payroll deductions	\$ 300.00		
436	INV DEDUCTION	13/09/2021	Lgia Super	Payroll deductions	\$ 186.17		
437	DD6882.5	13/09/2021	Rest Superannuation		\$ 241.35		
438	INV SUPER	13/09/2021	Rest Superannuation	Superannuation contributions	\$ 241.35		
439	DD6882.6	13/09/2021	Essential Super		\$ 204.37		
440	INV SUPER	13/09/2021	Essential Super	Superannuation contributions	\$ 204.37		
441	DD6882.7	13/09/2021	Oasis Superannuation Service		\$ 279.59		
442	INV SUPER	13/09/2021	Oasis Superannuation Service	Superannuation contributions	\$ 279.59		
443	DD6882.8	13/09/2021	Mercer Super Trust		\$ 166.72		
444	INV SUPER	13/09/2021	Mercer Super Trust	Superannuation contributions	\$ 166.72		
445	DD6882.9	13/09/2021	Colonial First State		\$ 814.02		
446	INV SUPER	13/09/2021	Colonial First State	Superannuation contributions	\$ 814.02		
447	DD6889.1	15/09/2021	Sandwai Pty Ltd		\$ 1,071.40		F
448	INV AUG2021	15/09/2021	Sandwai Pty Ltd	CHSP - INFORMATION SYSTEMS GEN - Monthly Charges August 2021	\$ 1,071.40		
449	DD6893.1	17/09/2021	Australian Taxation Office		\$ 24,827.00		
450	INV 310821	31/08/2021	Australian Taxation Office	BAS - August 2021	\$ 24,827.00		
451	DD6904.1	29/09/2021	Elgas		\$ 8,227.36		
452	INV 0360835055	22/09/2021	Elgas	NRLC - UTILITY - GAS - Gas Supplied 7,322.0L	\$ 8,227.36		
453	DD6907.1	29/09/2021	Telstra		\$ 1,880.00		PF
454	INV K350441160-7	12/09/2021	Telstra	VARIOUS DEPARTMENTS - Mobile Phone Charges September 2021	\$ 1,880.00		

	Chq/EFT/DD	Date	Name	Description	Invoice Amount	Payment Total	Type	Funding
455	DD6911.1	27/09/2021	Aware Super			\$ 14,790.38		
456	INV SUPER	27/09/2021	Aware Super	Superannuation contributions	\$ 12,609.85			
457	INV DEDUCTION	27/09/2021	Aware Super	Payroll deductions	\$ 260.00			
458	INV DEDUCTION	27/09/2021	Aware Super	Payroll deductions	\$ 150.00			
459	INV DEDUCTION	27/09/2021	Aware Super	Payroll deductions	\$ 185.45			
460	INV DEDUCTION	27/09/2021	Aware Super	Payroll deductions	\$ 348.99			
461	INV DEDUCTION	27/09/2021	Aware Super	Payroll deductions	\$ 848.17			
462	INV DEDUCTION	27/09/2021	Aware Super	Payroll deductions	\$ 387.92			
463	DD6911.2	27/09/2021	Cbus Super Fund			\$ 256.02		
464	INV SUPER	27/09/2021	Cbus Super Fund	Superannuation contributions	\$ 256.02			
465	DD6911.3	27/09/2021	Spirit Super			\$ 411.79		
466	INV SUPER	27/09/2021	Spirit Super	Superannuation contributions	\$ 308.84			
467	INV DEDUCTION	27/09/2021	Spirit Super	Payroll deductions	\$ 102.95			
468	DD6911.4	27/09/2021	Prime Super			\$ 639.66		
469	INV SUPER	27/09/2021	Prime Super	Superannuation contributions	\$ 639.66			
470	DD6911.5	27/09/2021	Lgia Super			\$ 993.91		
471	INV SUPER	27/09/2021	Lgia Super	Superannuation contributions	\$ 507.74			
472	INV DEDUCTION	27/09/2021	Lgia Super	Payroll deductions	\$ 300.00			
473	INV DEDUCTION	27/09/2021	Lgia Super	Payroll deductions	\$ 186.17			
474	DD6911.6	27/09/2021	Rest Superannuation			\$ 356.56		
475	INV SUPER	27/09/2021	Rest Superannuation	Superannuation contributions	\$ 356.56			
476	DD6911.7	27/09/2021	Essential Super			\$ 204.37		
477	INV SUPER	27/09/2021	Essential Super	Superannuation contributions	\$ 204.37			
478	DD6911.8	27/09/2021	Oasis Superannuation Service			\$ 259.47		
479	INV SUPER	27/09/2021	Oasis Superannuation Service	Superannuation contributions	\$ 259.47			

	Chq/EFT/DD	Date	Name	Description	Invoice Amount	Payment Total	Type	Funding
480	DD6911.9	27/09/2021	Mercer Super Trust			\$ 143.69		
481	INV SUPER	27/09/2021	Mercer Super Trust	Superannuation contributions	\$ 143.69			
482	DD6915.1	28/09/2021	Easifleet			\$ 924.70		
483	INV SEPT2021	28/09/2021	Easifleet	FIRE - MOTOR VEHICLE EXPENSES Lease of Holden Colorado (NGN 12398) for Bushfire Risk Planning Co-Ordinator - September 2021	\$ 924.70			
484	DD6918.1	30/09/2021	Aaron Joseph Cook			\$ 2,245.54		
485	INV CEO SEPTEMBER 2021	30/09/2021	Aaron Joseph Cook	CEO STAFF HOUSING RENTAL PROPERTY EXPENSES - Rent September 2021	\$ 2,245.54			
486	DD6882.10	13/09/2021	Bt Super For Life			\$ 474.83		
487	INV SUPER	13/09/2021	Bt Super For Life	Superannuation contributions	\$ 367.28			
488	INV DEDUCTION	13/09/2021	Bt Super For Life	Payroll deductions	\$ 107.55			
489	DD6882.11	13/09/2021	Host Plus			\$ 132.60		
490	INV SUPER	13/09/2021	Host Plus	Superannuation contributions	\$ 132.60			
491	DD6882.12	13/09/2021	Qsuper			\$ 380.31		
492	INV SUPER	13/09/2021	Qsuper	Superannuation contributions	\$ 380.31			
493	DD6882.13	13/09/2021	Care Super			\$ 293.46		
494	INV SUPER	13/09/2021	Care Super	Superannuation contributions	\$ 293.46			
495	DD6882.14	13/09/2021	ANZ Smart Choice Super			\$ 204.37		
496	INV SUPER	13/09/2021	ANZ Smart Choice Super	Superannuation contributions	\$ 204.37			
497	DD6882.15	13/09/2021	Bt Superwrap			\$ 443.01		
498	INV DEDUCTION	13/09/2021	Bt Superwrap	Payroll deductions	\$ 114.93			
499	INV SUPER	13/09/2021	Bt Superwrap	Superannuation contributions	\$ 328.08			
500	DD6882.16	13/09/2021	Sunsuper			\$ 575.12		
501	INV DEDUCTION	13/09/2021	Sunsuper	Payroll deductions	\$ 143.78			
502	INV SUPER	13/09/2021	Sunsuper	Superannuation contributions	\$ 431.34			

	Chq/EFT/DD	Date	Name	Description	Invoice Amount	Payment Total	Type	Funding
503	DD6882.17	13/09/2021	Hesta Superannuation			\$ 1,357.08		
504	INV SUPER	13/09/2021	Hesta Superannuation	Superannuation contributions	\$ 1,187.08			
505	INV DEDUCTION	13/09/2021	Hesta Superannuation	Payroll deductions	\$ 170.00			
506	DD6882.18	13/09/2021	Australiansuper			\$ 2,133.38		
507	INV DEDUCTION	13/09/2021	Australiansuper	Payroll deductions	\$ 115.86			
508	INV DEDUCTION	13/09/2021	Australiansuper	Payroll deductions	\$ 637.00			
509	INV SUPER	13/09/2021	Australiansuper	Superannuation contributions	\$ 1,380.52			
510	DD6882.19	13/09/2021	Mlc Masterkey			\$ 249.35		
511	INV SUPER	13/09/2021	Mlc Masterkey	Superannuation contributions	\$ 249.35			
512	DD6882.20	13/09/2021	Bt Super For Life			\$ 103.32		
513	INV SUPER	13/09/2021	Bt Super For Life	Superannuation contributions	\$ 103.32			
514	DD6882.21	13/09/2021	Cbus Super Fund			\$ 265.47		
515	INV SUPER	13/09/2021	Cbus Super Fund	Superannuation contributions	\$ 265.47			
516	DD6911.10	27/09/2021	Colonial First State			\$ 814.02		
517	INV SUPER	27/09/2021	Colonial First State	Superannuation contributions	\$ 814.02			
518	DD6911.11	27/09/2021	Bt Super For Life			\$ 537.86		
519	INV SUPER	27/09/2021	Bt Super For Life	Superannuation contributions	\$ 434.73			
520	INV DEDUCTION	27/09/2021	Bt Super For Life	Payroll deductions	\$ 103.13			
521	DD6911.12	27/09/2021	Qsuper			\$ 393.62		
522	INV SUPER	27/09/2021	Qsuper	Superannuation contributions	\$ 393.62			
523	DD6911.13	27/09/2021	Care Super			\$ 345.77		
524	INV SUPER	27/09/2021	Care Super	Superannuation contributions	\$ 345.77			
525	DD6911.14	27/09/2021	MyNorth Super			\$ 288.79		
526	INV SUPER	27/09/2021	MyNorth Super	Superannuation contributions	\$ 288.79			

	Chq/EFT/DD	Date	Name	Description	Invoice Amount	Payment Total	Type	Funding
527	DD6911.15	27/09/2021	ANZ Smart Choice Super			\$ 204.37		
528	INV SUPER	27/09/2021	ANZ Smart Choice Super	Superannuation contributions	\$ 204.37			
529	DD6911.16	27/09/2021	Bt Superwrap			\$ 443.01		
530	INV DEDUCTION	27/09/2021	Bt Superwrap	Payroll deductions	\$ 114.93			
531	INV SUPER	27/09/2021	Bt Superwrap	Superannuation contributions	\$ 328.08			
532	DD6911.17	27/09/2021	Host Plus			\$ 255.44		
533	INV SUPER	27/09/2021	Host Plus	Superannuation contributions	\$ 255.44			
534	DD6911.18	27/09/2021	Sunsuper			\$ 575.12		
535	INV DEDUCTION	27/09/2021	Sunsuper	Payroll deductions	\$ 143.78			
536	INV SUPER	27/09/2021	Sunsuper	Superannuation contributions	\$ 431.34			
537	DD6911.19	27/09/2021	Australiansuper			\$ 2,216.12		
538	INV DEDUCTION	27/09/2021	Australiansuper	Payroll deductions	\$ 111.49			
539	INV DEDUCTION	27/09/2021	Australiansuper	Payroll deductions	\$ 637.00			
540	INV SUPER	27/09/2021	Australiansuper	Superannuation contributions	\$ 1,467.63			
541	DD6911.20	27/09/2021	Hesta Superannuation			\$ 1,301.79		
542	INV DEDUCTION	27/09/2021	Hesta Superannuation	Payroll deductions	\$ 170.00			
543	INV SUPER	27/09/2021	Hesta Superannuation	Superannuation contributions	\$ 1,131.79			
544	DD6911.21	27/09/2021	Mlc Masterkey			\$ 249.35		
545	INV SUPER	27/09/2021	Mlc Masterkey	Superannuation contributions	\$ 249.35			
546	DD6911.22	27/09/2021	Bt Super For Life			\$ 142.78		
547	INV SUPER	27/09/2021	Bt Super For Life	Superannuation contributions	\$ 142.78			
Direct Debit Total					\$	108,020.75		

Credit Card Purchases

Chq/EFT/DD	Date	Name	Description	Invoice Amount	Payment Total	Type	Funding
CEO & EMCCS		GENERAL Credit Card Purchases					
548	21/09/2021	General Credit Card Purchases			\$ 6,211.21		PF
549	02/08/2021	General Credit Card Purchases	ADMIN - TRAINING & DEVELOPMENT - Quest Innaloo - Parking DOT Training (B Dorrington)	23.24			
550	30/08/2021	General Credit Card Purchases	CHCP - INFORMATION SYSTEMS - Xero - Xero Subscription September	26.00			
551	27/08/2021	General Credit Card Purchases	NO01 2019 HOLDEN COLORADO - Shire of Narrogin - New Vehicle Registration	374.45			
552	28/07/2021	General Credit Card Purchases	MEMBERS - PRINTING & STATIONERY - Officeworks - A3 Folders for Council Chambers	79.11			
553	02/08/2021	General Credit Card Purchases	CHCSP - ADVERTISING & PROMOTIONS - Facebook - Facebook Post Boost	18.17			
554	06/08/2021	General Credit Card Purchases	CHCP - RECRUITMENT - Seek - Seek Advertisement Homecare 'Scheduler Position	324.50			
555	06/08/2021	General Credit Card Purchases	CHCP - RECRUITMENT - Seek - Seek Advertisement Homecare 'Registered Nurse'	324.50			
556	06/08/2021	General Credit Card Purchases	MEMBERS - CIVIC FUNCTIONS, REFRESHMENTS & RECEPTIONS - Officeworks - Certificate Frames for Citizenship Ceremony & Hole Punch	278.26			
557	10/08/2021	General Credit Card Purchases	ROADM - ROAD MAINTENANCE - Wholesale SMS - Credit Top Up (Road Closures)	357.50			
558	10/08/2021	General Credit Card Purchases	MEMBERS - CIVIC FUNCTIONS, REFRESHMENTS & RECEPTIONS - R U OK Merchandise - R U OK Day Merchandise	895.53			
559	18/08/2021	General Credit Card Purchases	FIRE PREVENTION/BURNING/CONTROL - Wholesale SMS - Monthly SMS Charges	17.60			
560	06/08/2021	General Credit Card Purchases	INFORMATION SYSTEMS - Gogo Messages - Greeting Messages Admin & Homecare	151.80			
561	19/08/2021	General Credit Card Purchases	ROADM - ROAD MAINTENANCE - Wholesale SMS - Credit Top Up (Road Closures)	357.50			
562	19/08/2021	General Credit Card Purchases	ADMIN - TRAINING & DEVELOPMENT - WALGA - Registration Fee for Aboriginal Engagement & Reconciliation Forum (D Stewart)	140.00			
563	31/08/2021	General Credit Card Purchases	INVEST - BANK FEES AND CHARGES - NAB - Interest Charges August 2021	0.55			
564	09/08/2021	General Credit Card Purchases	CHSP - CUSTOMER SERVICES EXPENSES - Golden Carers - 12 Month Subscription	74.95			
565	10/08/2021	General Credit Card Purchases	ANIMAL - EXPENSED MINOR ASSET PURCHASES - Apple Store - iPhone 11 (N White)	1079.00			
566	12/08/2021	General Credit Card Purchases	COMMUNITY - RECRUITMENT - Seek - Seek Advertisement (CDSO)	313.50			
567	16/08/2021	General Credit Card Purchases	SAN - TRAINING & DEVELOPMENT - Event & Conference Co - Registration for Waste & Recycling Conference (EMDRS & SEHO)	1299.20			
568	20/08/2021	General Credit Card Purchases	NO01 2019 HOLDEN COLORADO - Shire of Narrogin - Plate Change NO01 to 1HGW039	30.50			
569	27/08/2021	General Credit Card Purchases	NGN13362 2016 TRAILER - Shire of Narrogin - New Vehicle Registration	45.35			

Chq/EFT/DD	Date	Name	Description	Invoice Amount	Payment Total	Type	Funding
570 DD6898.2	22/09/2021	General Credit Card Purchases			\$ 210.00		
571 DSAUG1121	27/08/2021	General Credit Card Purchases	ADMIN - TRAINING & DEVELOPMENT - Goomaling Tavern - LGIS Golf Day Accomodation (D Stewart, N White & C Allinson)	210.00			
572 DD6898.3	23/09/2021	General Credit Card Purchases			\$ 213.17		F
573 FLAUG0421	09/08/2021	General Credit Card Purchases	CHCP - CLIENT PURCHASES - Grab Rail, Shower Head & Hose	213.17			
Credit Card Total					\$6,634.38		

Trust Total					\$0.00		

Chq/EFT/DD	Date	Name	Description	Invoice Amount	Payment Total	Type	Funding
------------	------	------	-------------	----------------	---------------	------	---------

ABBREVIATIONS		Cheque Total (Less TD)	\$542.15	0.06%
PF	Partially Funded	Term Deposits (TD)		
I		EFT Total*	\$444,340.02	50.96%
F	Funded	Payroll Total*	\$312,338.46	35.82%
L	Local Supplier	Direct Debit Total	\$108,020.75	12.39%
R	Recoverable	Credit Card Total	\$6,634.38	0.76%
		Trust Total	\$0.00	0.00%
			\$871,875.76	100.00%
		Total (Less Term Deposits)	\$871,875.76	
	* Please note Payroll totals	Local Suppliers	\$144,992.22	16.63%
		Employees	\$312,338.46	35.82%
		Combined Total	\$457,330.68	52.45%

11.3.2 MONTHLY FINANCIAL REPORTS – SEPTEMBER 2021

File Reference	12.8.1
Disclosure of Interest	Neither the Author nor Authorising Officer have any Impartiality, Financial or Proximity Interest that requires disclosure.
Applicant	Nil
Previous Item Numbers	Nil
Date	18 October 2021
Author	Manisha Barthakur – Senior Finance Officer- Strategic
Authorising Officer	Alex Mulenga – Manager Corporate Services
Attachments	1. Monthly Financial Report for the period ended 30 September 2021.

Summary

In accordance with the Local Government Financial Management Regulations (1996), Regulation 34, the Shire is to prepare a monthly Statement of Financial Activity for notation by Council.

Background

Council is requested to review the September 2021 Monthly Financial Reports.

Consultation

Consultation has been undertaken with Executive Manager Corporate and Community Services.

Statutory Environment

Local Government (Financial Management) Regulations 1996, Regulation 34 applies.

Policy Implications

Nil

Financial Implications

All expenditure has been approved via adoption of the 2021/22 Annual Budget or resulting from a Council resolution.

Strategic Implications

Shire of Narrogin Strategic Community Plan 2017-2027	
Objective	4. Civic Leadership Objective (Continually enhance the Shire's organisational capacity to service the needs of a growing community)
Outcome:	4.1 An efficient and effective organisation

Comment/Conclusion

The September 2021 Monthly Financial Report is presented for review.

Voting Requirements

Simple Majority

OFFICERS' RECOMMENDATION AND COUNCIL RESOLUTION 1021.009

Moved: Cr Fisher

Seconded: Cr Alexander

That with respect to the Monthly Financial Reports for September 2021, Council note the Reports as presented.

CARRIED 9/0

MONTHLY FINANCIAL REPORT
(Containing the Statement of Financial Activity)
FOR THE PERIOD ENDED 30 SEPTEMBER 2021



LOCAL GOVERNMENT ACT 1995
LOCAL GOVERNMENT (FINANCIAL MANAGEMENT) REGULATIONS 1996

TABLE OF CONTENTS

Monthly Summary Information	2 - 3
Statement of Financial Activity	4
Significant Accounting Policies	5
Adjusted Net Current Assets	6
Material Variances	7
Receivables	8
Capital Acquisitions	9-12
Cash Backed Reserves	13

STATEMENT OF FINANCIAL ACTIVITY
FOR THE PERIOD ENDED 30 SEPTEMBER 2021

STATUTORY REPORTING PROGRAMS

	Ref Note	Adopted Annual Budget	Amended Annual Budget	YTD Budget (a)	YTD Actual (b)	Var. \$ (b)-(a)	Var. % (b)-(a)/(a)	Var.
		\$	\$	\$	\$	\$	%	
Opening Funding Surplus(Deficit)		2,394,166	2,394,166	2,394,166	2,394,166	0	0%	
Revenue from operating activities								
General Purpose Funding - Rates		5,117,093	5,117,093	5,117,093	5,118,465	1,372	0%	
General Purpose Funding - Other Governance		1,406,907	1,406,907	315,272	412,228	96,955	31%	▲
Law, Order and Public Safety		5,060	5,060	1,455	10	(1,445)	(99%)	▼
Health		353,275	353,275	159,137	6,428	(152,710)	(96%)	▼
Education and Welfare		19,950	19,950	4,988	1,222	(3,765)	(75%)	▼
Housing		2,034,744	2,034,745	514,050	603,929	89,879	17%	▲
Community Amenities		8,364	8,363	2,060	1,018	(1,042)	(51%)	▼
Recreation and Culture		1,133,155	1,133,155	789,220	936,652	147,432	19%	▲
Transport		66,916	66,916	4,044	17,559	13,515	334.2%	▲
Economic Services		284,138	284,138	69,444	184,639	115,196	166%	▲
Other Property and Services		365,849	365,849	91,437	83,577	(7,860)	(9%)	▼
		161,900	161,900	34,775	30,509	(4,266)	(0)	▼
		10,957,350	10,957,350	7,102,976	7,396,237	293,261	4%	
Expenditure from operating activities								
General Purpose Funding		(322,483)	(322,483)	(82,157)	(41,057)	41,100	50%	▲
Governance		(696,879)	(696,879)	(176,789)	(91,691)	85,099	48%	▲
Law, Order and Public Safety		(969,586)	(969,585)	(259,707)	(254,224)	5,483	2%	▲
Health		(303,363)	(303,363)	(81,374)	(58,375)	22,999	28%	▲
Education and Welfare		(1,571,410)	(1,571,411)	(416,932)	(468,731)	(51,799)	(12%)	▼
Housing		(35,823)	(35,823)	(7,040)	(7,925)	(885)	(13%)	▼
Community Amenities		(1,540,165)	(1,540,165)	(399,558)	(271,288)	128,270	32%	▲
Recreation and Culture		(3,213,503)	(3,213,503)	(827,925)	(575,561)	252,364	30%	▲
Transport		(3,869,121)	(3,869,127)	(3,868,899)	(765,349)	3,103,550	80%	▲
Economic Services		(832,006)	(832,006)	(832,006)	(159,762)	672,244	81%	▲
Other Property and Services		(148,508)	(148,508)	(115,288)	(291,469)	(176,181)	(153%)	▼
		(13,502,847)	(13,502,853)	(7,067,676)	(2,985,433)	4,082,243		
Operating activities excluded from budget								
Add back Depreciation		3,274,599	3,274,599	1,637,300	480,650	(1,156,649)	(71%)	▼
Adjust (Profit)/Loss on Asset Disposal	12	108,822	108,822	65,811	0	(65,811)	(100%)	▼
Adjust Employee Benefits Provision (Non-Current)		180	180	0	0	0		
Adjust Deferred Pensioner Rates (Non-Current)		0	0	0	0	0		
Movement in Leave Reserve (Added Back)		0	0	0	16	16	100%	
Adjust Rounding		0	0	0	0	0		
Amount attributable to operating activities		3,232,270	3,232,264	4,132,577	7,285,636	3,153,059		
Investing Activities								
Non-Operating Grants, Subsidies and Contributions		1,731,740	3,337,571	291,913	219,840	(72,073)	(25%)	▼
Land and Buildings	11	(2,526,000)	(2,526,000)	(277,500)	(118,680)	158,820	57%	▲
Plant and Equipment	11	(1,402,000)	(2,394,100)	(171,000)	(1,141)	169,859	99%	▲
Furniture and Equipment	11	(68,000)	(68,000)	0	0	0	100%	
Infrastructure Assets - Roads	11	(2,056,540)	(2,056,540)	0	(10,480)	(10,480)	100%	
Infrastructure Assets - Footpaths	11	(58,000)	(58,000)	0	0	0	100%	
Infrastructure Assets - Road Drainage	11	(30,000)	(30,000)	0	0	0	100%	
Infrastructure Assets - Parks and Gardens	11	(225,000)	(225,000)	0	0	0	100%	
Infrastructure Assets - Aerodromes	11	(99,554)	(99,554)	0	0	0	100%	
Infrastructure Assets - Other	11	(732,650)	(758,375)	(4,000)	(43,388)	(39,388)	(985%)	▼
Infrastructure Assets- Bridges	12	0	(588,000)	0	0	0		
Proceeds from Disposal of Assets	12	407,000	407,000	0	0	(0)	100%	
Proceeds from Sale of Investments		0	0	0	0	0		
Amount attributable to investing activities		(5,059,004)	(5,058,998)	(160,587)	35,671	196,258		
Financing Activities								
Proceeds from New Debentures	13	500,000	500,000	0	0	(0)	100%	
Repayment of Debentures	13	(206,412)	(206,412)	(28,188)	(9,374)	18,814	201%	▲
Transfer from Reserves	10	4,170,391	4,170,391	0	0	(0)	(100%)	▼
Transfer to Reserves	10	(2,637,245)	(2,637,245)	0	(179)	(179)	(100%)	▼
Amount attributable to financing activities		1,826,734	1,826,734	(28,188)	(9,554)	18,634		
Closing Funding Surplus(Deficit)	3	0	0	3,943,803	7,311,754	0	3,367,951	

KEY INFORMATION

▲ ▼ Indicates a variance between Year to Date (YTD) Budget and YTD Actual data as per the adopted materiality threshold.

Refer to Note 2 for an explanation of the reasons for the variance.

The material variance adopted by Council for the current year is \$15,000 or 10% whichever is the greater.

This statement is to be read in conjunction with the accompanying Financial Statements and notes.

**NOTES TO THE STATEMENT OF FINANCIAL ACTIVITY
FOR THE PERIOD ENDED 30 SEPTEMBER 2021**

**EXPLANATION OF
MATERIAL VARIANCES**

The material variance thresholds are adopted annually by Council as an indicator of whether the actual expenditure or revenue varies from the year to date. The material variance adopted by Council for the current year is an Actual Variance exceeding 10% and a value greater than \$15,000.

Reporting Program	Var. \$	Var. %	Var.	Timing/ Permanent	Explanation of Variance
	\$	%			
Revenue from operating activities					
General Purpose Funding - Other	96,955	31%	▲	Timing	Variance due to timing of receipt of Financial Assistance Grant for first quarter.
Law, Order and Public Safety	(152,710)	(96%)	▼	Timing	Timing of Receipt of \$135k fire; and timing of bushfire subsidy under Emergency Service Levy.
Education and Welfare	89,879	17%	▲	Timing	Variance of 90k due to timing of the CHCP Govt revenue.
Community Amenities	147,432	19%	▲	Timing	Variance due to timing of income commercial collection charges (sanitation-other) of 165k.
Transport	115,196	166%	▲	Timing	Variance due to receipt of Direct Road Grant (operational) of 154k from MRWA earlier than envisaged in budget.
Expenditure from operating activities					
General Purpose Funding	41,100	50%	▲	Timing	Variance due to timing of expenses related to debt collection and rates administration.
Governance	85,099	48%	▲	Timing	Variance due to timing of various overhead allocations admin allocated, audit fees, insurance & consulting fees.
Health	22,999	28%	▲	Timing	Timing of health inspection and admin costs.
Education and Welfare	(51,799)	(12%)	▼	Timing	Variance due to timing of Homecare expenses- CHSP and CHCP.
Community Amenities	128,270	32%	▲	Timing	Variance due to timing of expenditure related to waste management 85k, town planning and other community expenses of 10k, other community expenses of 20k such as maintenance of public toilets, buildings .
Recreation and Culture	252,364	30%	▲	Timing	Variance due to timing of NRLC utility expense of 50k; public hall and civic centre of 20k; 110k variance in parks and gardens maintenance expense and variance of 68k due to the timing of expenses related to other cultural events and activities.
Transport	3,103,550	80%	▲	Timing	Variance due to timing of maintenance expenses on roads, streets, bridges.
Economic Services	672,244	81%	▲	Timing	Variance mainly due to timing of expenses related to building control and maintenance of 40k; tourism promotion activities (mainly caravan park) of 10k.
Other Property and Services	(176,181)	(153%)	▼	Timing	Variance mainly due to the payment of annual software license and insurance costs early in the financial year.
Investing Activities					
Non-operating Grants, Subsidies and Contributions	(72,073)	(25%)	▼	Timing	Variance due to timing of MRWA Maintenance grant received earlier than budgeted.
Capital Acquisitions	268,331	59%	▲	Timing	Various capital expenditure (eg Railway Station project) progressing slower than expected and road plant purchases have been affected by global shortages.
Financing Activities					
Repayment of Debentures	18,814	201%	▲	Timing	Variance due to timing of loan repayments for NRLC, Halls and TOUR activities.

KEY INFORMATION

▲▼ Indicates a variance between Year to Date (YTD) Budget and YTD Actual data as per the adopted materiality threshold.

▲ Favourable variance

▼ Unfavourable variance

This statement is to be read in conjunction with the accompanying Financial Statements and notes.

**MONTHLY FINANCIAL REPORT
FOR THE PERIOD ENDED 30 SEPTEMBER 2021**

**MONTHLY SUMMARY
INFORMATION**

PREPARATION TIMING AND REVIEW

Date prepared: All known transactions up to reporting period.
Prepared by: Manager Corporate Services
Reviewed by: Executive Manager Corporate & Community Services

BASIS OF PREPARATION

REPORT PURPOSE

This report is prepared to meet the requirements of *Local Government (Financial Management) Regulations 1996 , Regulation 34* . Note: The statements and accompanying notes are prepared based on all transactions recorded at the time of preparation and may vary due to transactions being processed for the reporting period after the date of preparation.

BASIS OF ACCOUNTING

This statement comprises a special purpose financial report which has been prepared in accordance with Australian Accounting Standards (as they apply to local governments and not-for-profit entities and to the extent they are not in-consistent with the *Local Government Act 1995* and accompanying regulations), Australian Accounting Interpretations, other authoritative pronouncements of the Australian Accounting Standards Board, the *Local Government Act 1995* and accompanying regulations. Accounting policies which have been adopted in the preparation of this financial report have been consistently applied unless stated otherwise.

Except for cash flow and rate setting information, the report has been prepared on the accrual basis and is based on historical costs, modified, where applicable, by the measurement at fair value of selected non-current assets, financial assets and liabilities.

THE LOCAL GOVERNMENT REPORTING ENTITY

All Funds through which the Council controls resources to carry on its functions have been included in this statement. In the process of reporting on the local government as a single unit, all transactions and balances between those funds (for example, loans and transfers between Funds) have been eliminated.

SIGNIFICANT ACCOUNTING POLICIES

GOODS AND SERVICES TAX

Revenues, expenses and assets are recognised net of the amount of GST, except where the amount of GST incurred is not recoverable from the Australian Taxation Office (ATO). Receivables and payables are stated inclusive of GST receivable or payable. The net amount of GST recoverable from, or payable to, the ATO is included with receivables or payables in the statement of financial position. Cash flows are presented on a gross basis. The GST components of cash flows arising from investing or financing activities which are recoverable from, or payable to, the ATO are presented as operating cash flows.

CRITICAL ACCOUNTING ESTIMATES

The preparation of a financial report in conformity with Australian Accounting Standards requires management to make judgements, estimates and assumptions that effect the application of policies and reported amounts of assets and liabilities, income and expenses. The estimates and associated assumptions are based on historical experience and various other factors that are believed to be reasonable under the circumstances; the results of which form the basis of making the judgements about carrying values of assets and liabilities that are not readily apparent from other sources. Actual results may differ from these estimates.

ROUNDING OFF FIGURES

All figures shown in this statement are rounded to the nearest dollar.

**MONTHLY FINANCIAL REPORT
FOR THE PERIOD ENDED 30 SEPTEMBER 2021**

**MONTHLY SUMMARY INFORMATION
GRAPHS**

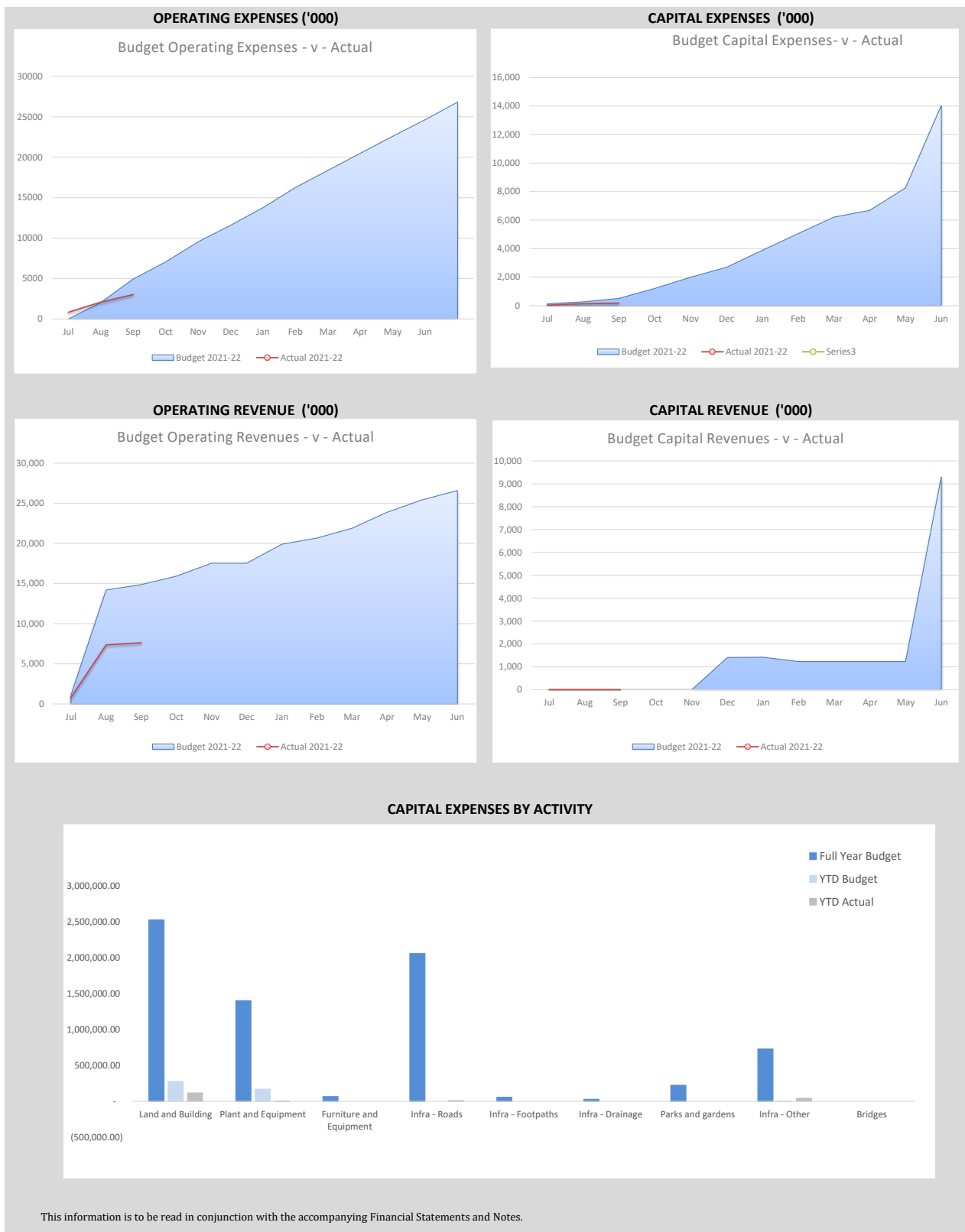

**NOTES TO THE STATEMENT OF FINANCIAL ACTIVITY
FOR THE PERIOD ENDED 30 SEPTEMBER 2021**

SIGNIFICANT ACCOUNTING POLICIES

CURRENT AND NON-CURRENT CLASSIFICATION

In the determination of whether an asset or liability is current or non-current, consideration is given to the time when each asset or liability is expected to be settled. The asset or liability is classified as current if it is expected to be settled within the next 12 months, being the Council's operational cycle. In the case of liabilities where Council does not have the unconditional right to defer settlement beyond 12 months, such as vested long service leave, the liability is classified as current even if not expected to be settled within the next 12 months. Inventories held for trading are classified as current even if not expected to be realised in the next 12 months except for land held for resale where it is held as non current based on Council's intentions to release for sale.

EMPLOYEE BENEFITS

The provisions for employee benefits relates to amounts expected to be paid for long service leave, annual leave, wages and salaries and are calculated as follows:

(i) Wages, Salaries, Annual Leave and Long Service Leave
(Short-term Benefits)

The provision for employees' benefits to wages, salaries, annual leave and long service leave expected to be settled within 12 months represents the amount the City has a present obligation to pay resulting from employees services provided to balance date. The provision has been calculated at nominal amounts based on remuneration rates the City expects to pay and includes related on-costs.

(ii) *Annual Leave and Long Service Leave (Long-term Benefits)*

The liability for long service leave is recognised in the provision for employee benefits and measured as the present value of expected future payments to be made in respect of services provided by employees up to the reporting date using the project unit credit method. Consideration is given to expected future wage and salary levels, experience of employee departures and periods of service. Expected future payments are discounted using market yields at the reporting date on national government bonds with terms to maturity and currency that match as closely as possible, the estimated future cash outflows. Where the City does not have the unconditional right to defer settlement beyond 12 months, the liability is recognised as a current liability.

PROVISIONS

Provisions are recognised when: The council has a present legal or constructive obligation as a result of past events; it is more likely than not that an outflow of resources will be required to settle the obligation; and the amount has been reliably estimated. Provisions are not recognised for future operating losses. Where there are a number of similar obligations, the likelihood that an outflow will be required in settlement is determined by considering the class of obligations as a whole. A provision is recognised even if the likelihood of an outflow with respect to any one of item included in the same class of obligations may be small.

INVENTORIES

Inventories are measured at the lower of cost and net realisable value. Net realisable value is the estimated selling price in the ordinary course of business less the estimated costs of completion and the estimated costs necessary to make the sale.

**NOTES TO THE STATEMENT OF FINANCIAL ACTIVITY
FOR THE PERIOD ENDED 30 SEPTEMBER 2021**

**OPERATING ACTIVITIES
RECEIVABLES**

Rates Receivable	31 Jul 21	30 Sep 21	Receivables - General	Current	30 Days	60 Days	90+ Days	Total
	\$	\$		\$	\$	\$	\$	\$
Opening Arrears Previous Years	495,899	476,999	Receivables - General	25,615	1,606	7,188	4,649	39,058
Levied this year	3,175,827	3,238,638	Percentage	66%	4%	18%	12%	
Movement in Excess Rates	0	0						
Domestic Refuse Collection Charges	476,713	493,769						
Domestic Services (Additional)	3,164	3,744						
Commercial Collection Charge	0	45,171	Balance per Trial Balance					
Commercial Collection Charge (Additional)	43,178	45,850	Rates Pensioner Rebate Claims					36,330
Total Rates and Rubbish (YTD)	5,452,101	5,695,912	GST Input					87,102
Less Collections to date	(5,471,001)	(1,031,726)	Provision For Doubtful Debts					(75,000)
Net Rates Collectable	476,999	5,141,185	Total Receivables General Outstanding					87,490
% Collected	90.24%	18.11%	Amounts shown above include GST (where applicable)					
Pensioner Deferred Rates		(180,497)						
Pensioner Deferred ESL		(8,464)						
Total Rates and Rubbish, ESL, Excess Rates		4,952,225						

KEY INFORMATION

Trade and other receivables include amounts due from ratepayers for unpaid rates and service charges and other amounts due from third parties for goods sold and services performed in the ordinary course of business.

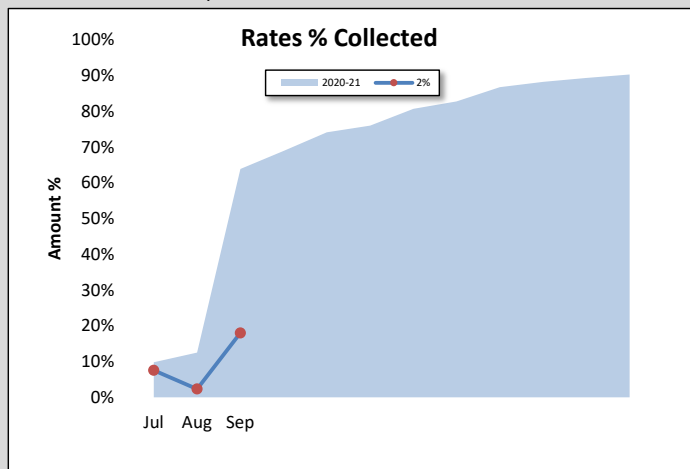

Collected

18%

Rates Due

\$4,952,225

SIGNIFICANT ACCOUNTING POLICIES

Trade and other receivables include amounts due from ratepayers for unpaid rates and service charges and other amounts due from third parties for goods sold and services performed in the ordinary course of business. Receivables expected to be collected within 12 months of the end of the reporting period are classified as current assets. All other receivables are classified as non-current assets. Collectability of trade and other receivables is reviewed on an ongoing basis. Debts that are known to be uncollectible are written off when identified. An allowance for doubtful debts is raised when there is objective evidence that they will not be collectible.

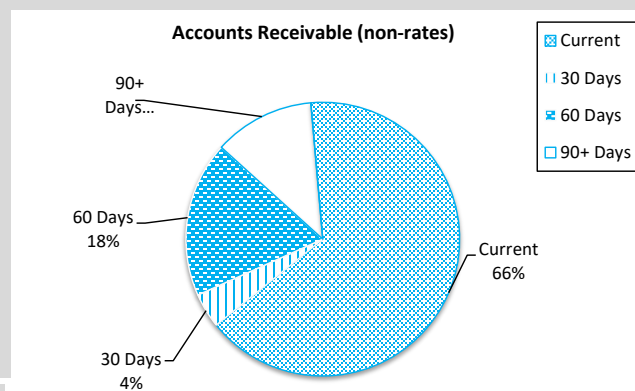

Debtors Due

\$87,490

Over 30 Days

34%

Over 90 Days

12%

NOTES TO THE STATEMENT OF FINANCIAL ACTIVITY
FOR THE PERIOD ENDED 30 SEPTEMBER 2021

OPERATING ACTIVITIES
ADJUSTED NET CURRENT ASSETS

	Last Years Closing	This Time Last Year	Year to Date Actual
	30 Jun 2021	30 Sep 2020	30 Sep 2021
	\$	\$	\$
Adjusted Net Current Assets			
Current Assets			
Cash Unrestricted	2,240,052	6,306,907	2,541,035
Cash Restricted - Reserves	4,960,977	4,083,830	4,961,324
Cash Restricted - Bonds/Deposits	30,003	22,872	30,069
Receivables - Rates and Rubbish, ESL, Excess Rates	418,639	1,960,701	4,952,225
Receivables - Other	165,702	80,038	210,875
Inventories	9,960	17,676	24,745
	7,825,332	12,472,024	12,720,273
Less: Current Liabilities			
Payables	(125,875)	(406,094)	(281,681)
Loan Liability	(197,212)	(164,768)	(398,926)
Provisions	(705,287)	(711,328)	(527,252)
	(1,028,373)	(1,282,190)	(1,207,858)
Net Current Asset Position	6,796,959	11,189,834	11,512,416
Less: Cash Restricted	(4,960,977)	(4,083,830)	(4,961,324)
Add Back: Component of Leave Liability not Required to be funded	360,972	360,583	361,003
Add Back: Current Loan Liability	197,212	164,768	398,926
Adjustment for Trust Transactions Within Muni	0	(6,386)	734
Net Current Funding Position	2,394,166	7,624,968	7,311,754

SIGNIFICANT ACCOUNTING POLICIES

Please see page 5 for information on significant accounting policies relating to Net Current Assets.

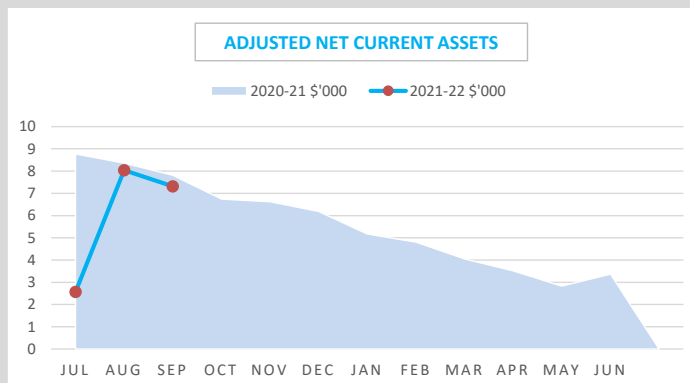

KEY INFORMATION

The amount of the adjusted net current assets at the end of the period represents the actual surplus (or deficit if the figure is a negative) as presented on the Rate Setting Statement.

Year YTD Actual

Surplus(Deficit)

\$7.31 M

This Time Last Year

Surplus(Deficit)

\$7.62 M

**NOTES TO THE STATEMENT OF FINANCIAL ACTIVITY
FOR THE PERIOD ENDED 30 SEPTEMBER 2021**

**INVESTING ACTIVITIES
CAPITAL ACQUISITIONS**

Capital Acquisitions	Adopted Budget	Current Budget	YTD Budget	YTD Actual Total	YTD Budget Variance
	\$	\$	\$	\$	\$
Land and Buildings	2,526,000	2,526,000	277,500	118,680	158,820
Plant & Equipment	1,402,000	2,394,100	171,000	1,141	169,859
Furniture & Equipment	68,000	68,000	0	(0)	0
Roads	2,056,540	2,056,540	0	10,480	(10,480)
Footpaths	58,000	58,000	0	0	0
Road Drainage	30,000	30,000	0	0	0
Infrastructure- Bridges	0	588,000			
Other Infrastructure	732,650	758,381	4,000	43,388	(39,388)
Parks and Gardens	225,000	225,000	0	0	0
Aerodromes	99,554	99,554	0	0	0
Bridges	0	0	0	0	0
Capital Expenditure Totals	7,197,744	8,803,575	452,500	173,689	278,811

SIGNIFICANT ACCOUNTING POLICIES

All assets are initially recognised at cost. Cost is determined as the fair value of the assets given as consideration plus costs incidental to the acquisition. For assets acquired at no cost or for nominal consideration, cost is determined as fair value at the date of acquisition. The cost of non-current assets constructed by the local government includes the cost of all materials used in the construction, direct labour on the project and an appropriate proportion of variable and fixed overhead. Certain asset classes may be revalued on a regular basis such that the carrying values are not materially different from fair value. Assets carried at fair value are to be revalued with sufficient regularity to ensure the carrying amount does not differ materially from that determined using fair value at reporting date.

KEY INFORMATION

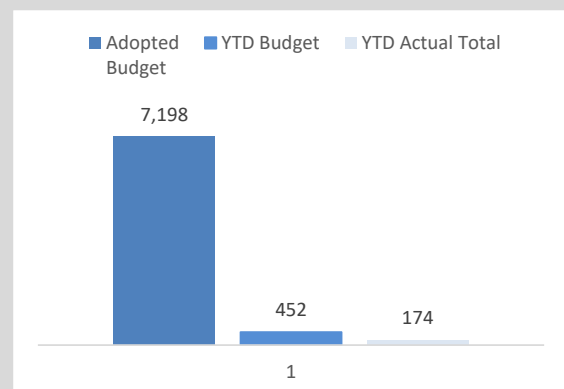

Acquisitions	Current Annual Budget	Current Budget	YTD Actual	% Spent
	\$7.2 M	\$8.8 M	\$.17 M	2%

To be read in conjunction with Strategic Projects Tracker

NOTES TO THE STATEMENT OF FINANCIAL ACTIVITY
FOR THE PERIOD ENDED 30 SEPTEMBER 2021INVESTING ACTIVITIES
CAPITAL ACQUISITIONS (CONTINUED)

% of Completion		Level of completion indicator, please see table at the end of this note for further detail.						
		Account Number	JOB	Adopted Budget	Current Budget	YTD Budget	YTD Actual	YTD Variance Under(Over)
				\$	\$	\$	\$	\$
Capital Expenditure								
Land and Buildings								
0.00		Hacc-Jessie house	4080360	BC052	900,000	900,000	0	0
0.00		Staff Housing	4090150	BC100	500,000	500,000	0	0
		Smith St Public toilets(Coles Carpark)	4100850	BC132	0	0	151	(151)
0.00		Town Hall (Federal St) Building Capital	4110160	BC156	30,000	30,000	7,500	7,500
0.00		Town Hall (Federal St) Fire Panel replacement	4110160	BC155	25,000	25,000	0	0
0.90		Town Hall Parapet Wall concrete Capping	4110160	BC180	20,000	20,000	20,000	18,000
0.00		NRLC Building Cap-Architectural Planning Study Concept Plan	4110260	BC165	20,000	20,000	0	0
0.00		Heritage- Laptop Upgrade for heritage Court House Museum	4110650	PE061	2,000	2,000	500	500
0.01		ANZAC war memorial repair & restoration	4110660	BC203	50,000	50,000	0	600
0.00		Fitout of Railway Station Building	4110660	BC207	50,000	50,000	0	0
0.00		Museum Restoration as per conservation Report	4110660	BC201	60,000	60,000	0	0
0.02		COM AMEN - Building (Capital) - CBD Ablution Upgrades	4100850	BC267	110,000	110,000	55,000	2,276
0.00		NRLC Building Capital 2018-19	4110260	BC161	40,000	40,000	0	0
0.00		Library - Stage 2	4110560	IO080B	20,000	20,000	0	0
0.19		Railway Station Resortation COVID recovery project	4110660	BC202	389,000	389,000	194,500	74,247
0.08		Caravan Park- Renewal Development including reseal	4130260	BC237	310,000	310,000	0	23,405
					2,526,000	2,526,000	277,500	118,680
								158,820
Plant and Equipment								
0.00		Acquisition of Incident Control Vehicle	4050255	PA950	0	881,900	0	0
0.00		Acquisition of General Rescue Utility	4050255	PA951	0	110,200	0	0
0.00		CHCP- new Mitsubishi Outlander P10	4080455	PA010B	38,000	38,000	38,000	0
0.00		CHCP- new Toyota Camry P15	4080455	PA015B	28,000	28,000	28,000	0
0.00		CHCP- new fleet vehicle	4080455	PA071A	25,000	25,000	25,000	0
0.00		NGN219 CATS Vehicle 2021	4080750	PA014H	25,000	25,000	25,000	0
0.00		NGN00 EMDRS Vehicle 2021(1)	4100655	PA002L	55,000	55,000	0	0
0.00		NRLC-Manual Pool Vacuum	4110255	PE071	5,000	5,000	0	0
0.00		NRLC-Capital Emergency Reparis eg - Pool Filters-YMCA	4110255	PE072	96,000	96,000	0	0
0.00		NRLC-Capital Emergency Reparis eg - Pool Liner-YMCA	4110255	PE073	80,000	80,000	0	0
0.00		NRLC-Capital Emergency Reparis eg - Boiler-YMCA	4110255	PE074	75,000	75,000	0	0
0.00		ONO EMTRS Vehicle 2021 (1)	4120350	PA700L	55,000	55,000	0	0
0.00		Multi Tyre Roller (p8517)	4120350	PA8517	170,000	170,000	0	0
0.00		Flocon (p8215) Roadsealing - Trade old Flocon and purchase new	4120350	PA8215	350,000	350,000	0	0
0.00		Toro Lawn Mower (p59)	4120350	PA059A	35,000	35,000	0	0
0.00		Leading Hand Parks 4*4 vehicle (p21)	4120350	PA021B	35,000	35,000	0	0
0.00		MO Vehicle (p967)	4120350	PA967H	55,000	55,000	55,000	0
0.00		Construction Foreman 4x4 Vehicle (p8164)	4120350	PA8164B	45,000	45,000	0	0
0.00		Maintenance Foreman 4x4 Vehicle (p26)	4120350	PA026C	45,000	45,000	0	0
0.00		Parks Utility (p17)	4120350	PA017B	30,000	30,000	0	0
0.00		Building Surveyor Vehicle (p6)	4130350	PA006C	30,000	30,000	0	0
0.00		CEO Vehicle (p1)	4140585	PA001K	70,000	70,000	0	0
0.00		ONgn Emccs Vehicle 2019(2)	4140585	PA005K	55,000	55,000	0	0
1.00		NGN 0 MLC Vehicle 2018	4140655	PA004D	0	0	0	0

NOTES TO THE STATEMENT OF FINANCIAL ACTIVITY
FOR THE PERIOD ENDED 30 SEPTEMBER 2021INVESTING ACTIVITIES
CAPITAL ACQUISITIONS (CONTINUED)

% of Completion

Level of completion indicator, please see table at the end of this note for further detail.

		Account Number	JOB	Adopted Budget	Current Budget	YTD Budget	YTD Actual	YTD Variance Under(Over)
				1,402,000	2,394,100	171,000	1,141	169,859
		Furniture and Equipment						
1.00		Governance Furniture & Equipment Replacements	FE028	0	0	0	(0)	0
		Admin Building CCTV	FE035	11,000	11,000	0	0	0
0.00		Altus HR system	FE101	57,000	57,000	0	0	0
				68,000	68,000	0	(0)	0
		Infrastructure - Roads						
0.00		Wandering Road - Stabilise Defects	IR332	92,996	92,996	0	0	0
0.00		Leak St - New Seal over gravel	IR108	22,574	22,574	0	0	0
0.00		Chipper St - New Seal over gravel	IR106	21,410	21,410	0	0	0
0.00		Quigley st- New Seal over gravel	IR088	22,950	22,950	0	0	0
0.00		Narrogin Valley Rd - New Seal over gravel	IR212	139,916	139,916	0	0	0
0.00		Chomley Rd - Gravel re sheet	IR213	75,658	75,658	0	0	0
0.00		Spriggs Rd - Gravel re sheet	IR258	99,498	99,498	0	0	0
0.00		Cannell Rd - Gravel re sheet	IR336	161,230	161,230	0	0	0
0.00		Booth St - Gravel re sheet	IR065	25,060	25,060	0	0	0
0.00		Marrumucking Rd - Gravel re sheet	IR261	100,648	100,648	0	0	0
0.00		Congelin Narrogin Rd	R2R202	30,395	30,395	0	0	0
0.00		Florence Ave	R2R110	4,245	4,245	0	0	0
0.00		Goldsmith St	R2R053	3,520	3,520	0	0	0
0.00		Lavator St	R2R283	60,245	60,245	0	0	0
0.00		Normans Lake Siding Rd Renewal (R2R)	R2R255	65,125	65,125	0	0	0
0.00		Narrogin-Harrismith Road - Renewal (Local) (R2R)	R2R331	44,720	44,720	0	0	0
0.00		Ried Rd Renewal (R2R)	R2R333	48,845	48,845	0	0	0
0.00		Sagar St	R2R086	4,195	4,195	0	0	0
0.00		Scadden St	R2R070	21,355	21,355	0	0	0
0.00		Tarwonga Rd	R2R204	35,845	35,845	0	0	0
0.00		Tuhoy St	R2R127	2,355	2,355	0	0	0
0.00		Wald St	R2R113	3,255	3,255	0	0	0
0.00		Earl St	R2R002B	51,000	51,000	0	0	0
		Wagin-Wickepin Road - Renewal (Rural) (RRG)	RRG207	550,899	550,899	0	10,276	(10,276)
		Narrogin Harrismith - Stabilise defects	RRG331	236,601	236,601	0	0	0
0.00		Tarwonga Road Black Spot	RBS204	132,000	132,000	0	0	0
				2,056,540	2,056,540	0	10,480	(10,480)
		Infrastructure - Footpaths						
		Ensign St Footpath	IF003	50,000	50,000	0	0	0
		Concrete Paths For Wilbur Park	IF053	8,000	8,000	0	0	0
				58,000	58,000	0	0	0
		Infrastructure - Drainage						
0.00		Drainage Easement Falcon St	ID000	30,000	30,000	0	0	0
				30,000	30,000			

NOTES TO THE STATEMENT OF FINANCIAL ACTIVITY
FOR THE PERIOD ENDED 30 SEPTEMBER 2021INVESTING ACTIVITIES
CAPITAL ACQUISITIONS (CONTINUED)

% of Completion		Level of completion indicator, please see table at the end of this note for further detail.							
		Account Number	JOB	Adopted Budget	Current Budget	YTD Budget	YTD Actual	YTD Variance Under(Over)	
				30,000	30,000	0	0	0	
		Infrastructure - Bridges							
		Tarwonga Rd Bridge 4551	4120181	IB204	0	192,000	0	0	
0.00		Whinbin Rock Rd Bridge 3125	4120181	IB205	0	396,000	0	0	
				0	588,000	0	0	0	
		Infrastructure - Other							
0.80		TWIS Dams	4100350	IO078	51,500	51,500	0	41,131	(41,131)
0.02		Cemetery Upgrade	4100860	IO026	138,960	138,960	0	2,257	(2,257)
		LED Lighting Upper Great Southern Hockey Association	4110265	IO164	330,000	330,000	0	0	0
		May St Stormwater Catchment Dam	4110365	IO180	169,190	169,190	0	0	0
		Public Arts projects identified by Townscape committee	4110860	IO113	25,000	25,000	0	0	0
0.00		Projects NEXIS (Capital)	4100860	IO150	8,000	8,000	4,000	0	4,000
0.00		Acquisition of Fast Fill Trailer	4050155	PA952	0	7,000	0	0	0
0.00		Narrogin Central BFB 120,000L Water Tank	4050165	IO134	0	8,919	0	0	0
0.00		Nomans Lake BFB 110,000L Water Tank	4050165	IO135	0	9,812	0	0	0
0.00		Water Pump For Depot Tanks - 3 Phase/ 3inch Transfer Pump	4120466	PE081	10,000	10,000	0	0	0
1.00		Caravan Park Resealing, Line Marking	4130265	IO081	0	0	0	0	0
				732,650	758,381	4,000	43,388	(39,388)	
		Infrastructure - Parks & Gardens							
0.00		Electric BBQ For Highbury near Tennis Courts	4110360	IO124	10,000	10,000	0	0	0
0.00		Parks Naming Project	4110360	IO128	15,000	15,000	0	0	0
0.00		Walk Cycle & Mountain Bike Trails Projects	4110360	IO129	200,000	200,000	0	0	0
				225,000	225,000	0	0	0	
		Infrastructure - Aerodromes							
		RADS Grant Narrogin Airport Patient Transfer Apron	4120460	BC220	69,554	69,554	0	0	0
		Narrogin airport-Patient transfer facility	4120460	BC221	30,000	30,000	0	0	0
				99,554	99,554	0			
		Grand Total			7,197,744	8,803,575	452,500	173,689	278,811

NOTES TO THE STATEMENT OF FINANCIAL ACTIVITY
FOR THE PERIOD ENDED 30 SEPTEMBER 2021

OPERATING ACTIVITIES
CASH AND INVESTMENTS

Cash Backed Reserve

Reserve Name	Opening Balance	Current Budget Interest Earned	Actual Interest Earned	Current Budget Transfers In (+)	Actual Transfers In (+)	Current Budget Transfers Out (-)	Actual Transfers Out (-)	Current Budget Closing Balance	Actual YTD Closing Balance
	\$	\$	\$	\$	\$	\$	\$	\$	\$
Refuse	575,351	280	41	38,737	0	23,848	0	590,520	575,392
CAT Vehicle Replacement Building	8,492	0	0	8,000	0	10,000	0	6,492	8,492
Employee Entitlement	370,750	180	41	0	0	196,000	0	174,930	370,791
Plant, Vehicle & Equipment	360,581	180	31	0	0	0	0	360,761	360,612
Economic Development	472,420	230	34	425,000	0	677,000	0	220,650	472,453
NRLC	227,022	110	19	0	0	200,000	0	27,132	227,041
Tourism & Area Promotion	241,743	120	24	100,120	0	251,000	0	90,983	241,767
HACC	78,521	30	6	0	0	0	0	78,551	78,527
CHCP	448,109	134	41	0	0	448,243	0	896,486	448,150
CHSP	566,113	280	18	759,634	0	994,907	0	331,120	566,131
IT & Office Equipment	464,195	230	27	1,223,070	0	873,384	0	814,111	464,222
Road Construction	26,311	10	6	0	0	20,000	0	6,321	26,318
Asset Valuation	335,003	160	29	0	0	0	0	335,163	335,032
Unspent Grants and Contributions	31,844	10	2	0	0	0	0	31,854	31,846
Landcare	563,029	280	16	0	0	376,435	0	186,874	563,045
Narrogin Airport	92,363	40	8	0	0	25,000	0	67,403	92,372
Water Reuse Schemes	40,171	20	0	15,000	2	0	0	55,191	40,173
Bridges	22,145	0	0	17,500	0	35,000	0	4,645	22,145
	17,500	10	0	48,000	0	39,574	0	25,936	17,500
	4,941,663	2,304	345	2,635,061	2	4,170,391	0	4,305,123	4,942,010

KEY INFORMATION

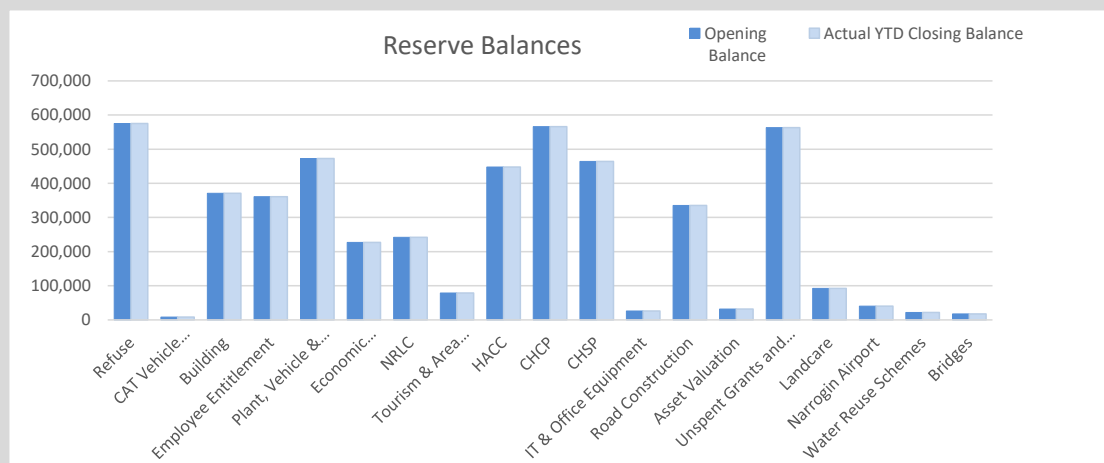

**NOTES TO THE STATEMENT OF FINANCIAL ACTIVITY
FOR THE PERIOD ENDED 30 SEPTEMBER 2021**

BUDGET AMENDMENTS

Amendments to original budget since budget adoption. Surplus/(Deficit)

Date	GL / Job Number	Description	Council Resolution	Classification	Non Cash Adjustment	Increase in Available Cash	Decrease in Available Cash	Amended Budget Running Balance
22/09/2021	PA950	Acquisition of Incident Control Vehicle	0921.006	Capital Expenditure			(881,900)	(881,900)
22/09/2021	PA951	Acquisition of General Rescue Utility	0921.006	Capital Expenditure			(110,200)	(992,100)
22/09/2021	3050202	ESL - SES Capital Grant GEN	0921.006	Capital Income		992,100		0
22/09/2021	PA952	Acquisition of Fast Fill Trailer	0921.006	Capital Expenditure			(7,000)	(7,000)
22/09/2021	IO134	Narrogin Central BFB 120,000L Water Tank	0921.006	Capital Expenditure			(8,919)	(15,919)
22/09/2021	IO135	Nomans Lake BFB 110,000L Water Tank	0921.006	Capital Expenditure			(9,812)	(25,731)
22/09/2021	5050152	FIRE - Grants GEN	0921.006	Capital Income		25,731		0
22/09/2021	IB205	Whinbin Rock Rd Bridge 3125	0921.006	Capital Expenditure			(192,000)	(192,000)
22/09/2021	IB204	Tarwonga Rd Bridge 4551	0921.006	Capital Expenditure			(396,000)	(588,000)
22/09/2021	3120112	ROADC - Other Grants - Roads/Streets GEN	0921.006	Capital Income		588,000		0

Shire of Narrogin
Strategic Projects 2021/22

For the Period Ended 30 September 2021

Project Progress	
Complete	
On Track	
Off Track	
In Trouble	

Item #	Account Number	GL / Job	Project Description	1/07/2021	30/09/2021	Responsible Officer		1st Quarter Jul- Sep	2nd Quarter Oct - Dec	3rd Quarter Jan - Mar	4th Quarter Apr - Jul	Comment
				2020/21 Current Budget	Total Committed Expenditure							
Governance												
Members of Council												
1	4040250	FE035	Admin Building CCTV	11,000.01	11,358.50	Frank Ludovico						On Track - Started (Project Commenced)
Education & Welfare												
Home and Community Care (HACC)												
Commonwealth Home Care Packages (CHCP)												
3	4080360	BC052	Relocation of Home & Community Care	900,000.00	29,355.00	Frank Ludovico						On Track
4	4080455	PA010B	Trade NGN847 Mitsubishi Outlander (P10)	38,000.00	13,305.10	Frank Ludovico						Purchase Order issued August 2021
5	4080455	PA015B	Replacement for Caddy NGN1155 (P15)	28,000.00	3,349.50	Frank Ludovico						Purchase Order issued August 2021
6	4050355	PA014H	NGN219 CATS Vehicle 2021	25,000.00	-	Frank Ludovico						Off track - Purchase Order issued October 2021
7	4080455	PA071A	Purchase new Fleet vehicle (CHCP)	25,000.00	21,758.59	Frank Ludovico						Purchase Order issued August 2021
Housing												
7	4090150	BC100	Staff Housing Building (Capital)	500,000.01	-	Dale Stewart						On Track
Community Amenities												
Other Community Amenities												
8	4100850	BC267	Smith Street Ablution Upgrade	109,999.98	101,718.63	Azhar Awang						Construction commenced - On Track as per schedule
9	4100350	IO078	TWIS Dams	51,500.01	41,131.25	Torre Evans						Completed (Payment may not be made)
Cemetery												
1	4100860	IO026	Cemetery Upgrade	138,960.00	2,256.91	Torre Evans						Started - On Track
Recreation & Culture												
Public Halls, Civic Centres												
13	4110160	BC155	Town Hall Fire Panel Replacement	24,999.99	-	Azhar Awang						Purchase Order to be issued - On Track
14	4110160	BC180	Parapet Wall Concrete Capping Town Hall	20,000.01	18,000.00	Torre Evans						Completed
15	4110160	BC150	Town Hall Stage Rigging	30,000.00	-	Torre Evans						On Track
Narrogin Regional Leisure Centre												
16	4110260	BC165	Architectural Planning Study Concept Plan NRLC	19,999.98	-	Azhar Awang						Not Started
17	4110260	BC161	NRLC Building Capital 2018-19	40,000.02	-	Azhar Awang						Seeking quotes
18	4110255	PE071	Manual Pool Vacuum	5,000.00	-	Azhar Awang						With YMCA Management
19	4110255	PE072	Capital Emergency Reparis eg - Pool Filters-YMCA	96,000.03	-	Azhar Awang						Not Started - only when required
20	4110255	PE073	Capital Emergency Reparis eg - Pool Liner-YMCA	80,000.01	-	Azhar Awang						
21	4110255	PE074	Capital Emergency Reparis eg - Boiler-YMCA	74,999.97	-	Azhar Awang						
22	4110265	IO164	LED Lighting Upper Great Southern Hockey Association	330,000.03	-	Azhar Awang						Not Started
Other Recreation & Sport												
1	4110360	IO124	Electric BBQ For Highbury near Tennis Courts	9,999.99	-	Torre Evans						Not Started - On Track
2	4110360	IO128	Parks Naming Project	15,000.00	-	Torre Evans						Not Started
3	4110360	IO129	Walk Cycle & Mountain Bike Trails Projects	199,999.98	-	Azhar Awang						Funds received, MLC to action plan (Not Started)
3	4110365	IO180	May St Stormwater Catchment Dam	169,190.01	-	Torre Evans						Not started, waiting for confirmation from Minister for grant
Libraries												
27	4110560	IO080B	Library Expansion Project Planning	20,000.01	-	Frank Ludovico						Seeking an Architect - On Track
Heritage												
1	4110660	BC203	ANZAC War memorial repair & restoration	50,000.01	600.00	Azhar Awang						Structural report received - RFQ to commence
2	4110650	PE061	Heritage - Laptop Upgrade for Heritage Court House Museum	2,000.04	-	Azhar Awang						On Track
3	4110660	BC207	Fitout of Railway Station Building	50,000.01	-	Dale Stewart						
4	4110660	BC201	Museum Restoration as per conservation Report	60,000.00	-	Azhar Awang						Structural report received - RFQ to commence

Item #	Account Number	GL / Job	Project Description	2020/21 Current Budget	Total Committed Expenditure	Responsible Officer		1st Quarter Jul- Sep	2nd Quarter Oct - Dec	3rd Quarter Jan - Mar	4th Quarter Apr - Jul	Comment
1	4120460	BC220	Aerodrome Building (Capital)	69,554.01	-	Torre Evans	●					Not Started
2	4120460	BC221	Narrogin airport-Patient transfer facility	30,000.00	-	Torre Evans	●					
			Economic Services									
			Tourism & Area Promotion									
1	4130260	BC237	Caravan Park - Renewal Development	309,999.99	113,788.35	Torre Evans	●					Started, On Track
			Other Property & Services									
			Administration Overheads									
1	4140580	FE101	Purchase of Altus HR system	57,000.00	56,489.00	Frank Ludovico	●					Purchase Order issued for Installation in March 2022

80	TOTAL PROJECTS			7,197,744.06	1,926,036.41							
-----------	-----------------------	--	--	--------------	--------------	--	--	--	--	--	--	--

Capital Projects	7,197,744.06	1,926,036.41
Operational Projects	-	-
	7,197,744.06	1,926,036.41

Value of Original Budget of Completed Projects:	\$126,500.01	Total projects:	80
Value of Actuals of Completed Projects:	\$113,010.49	Total complete:	3
\$ Under / (Over) of Completed Projects:	\$13,489.52	% complete:	4%
Actual v's Budget of Completed Projects %:	89.34%		

11.4 OFFICE OF THE CHIEF EXECUTIVE OFFICER

11.4.1 ESTABLISHMENT OF COUNCIL COMMITTEES AND REFERENCE GROUPS

File Reference	13.3.2 & 15.1.1
Disclosure of Interest	Neither the Author nor Authorising Officer have any Impartiality, Financial or Proximity Interests that requires disclosure.
Applicant	Shire of Narrogin
Previous Item Numbers	None
Date	12 October 2021
Author	Dale Stewart – Chief Executive Officer
Authorising Officer	Dale Stewart – Chief Executive Officer
Attachments	1. Draft Terms of Reference Council Committees and Reference Groups

Summary

Council's consideration of the needs for various Committees and Working Groups, together with their Terms of Reference, is requested.

Background

The Local Government Act 1995 and Emergency Management Act 2005 requires the establishment of the following committees:

- Audit Committee; and
- Local Emergency Management Committee.

The legislation specifies various roles and duties of these committees which have been incorporated into the Terms of Reference previously resolved.

Legislation permits, but does not require, the establishment of committees for other purposes.

The Local Government Act 1995 also specifies the requirements for establishment of committees, appointment of members and deputies, tenure etc.

Comment

The draft document attached, incorporates the changes to composition, roles and scope of the committees and reference groups since the last full review considered at the October 2019 Council Meeting.

Other than the two committees noted, all others are at Council's discretion with the exception of the OSH Workplace Committee which reports to the CEO.

Committees under the Local Government Act may be delegated powers from Council, in which case, additional requirements are imposed on the committee and the members of the committee. The Terms of Reference for Committees and Reference Groups have been developed on the basis that no

delegation of powers are to be made to any committee. Delegations to Reference Groups are not permitted by the Act.

The Act does not specifically require that committee's establishment and terms of reference(s) are reviewed. Once established, the committee continues until disbanded by resolution of Council, and the committee's terms of reference continue until amended by resolution of Council.

However, as tenure for the members of a committee (including community members) (Section 5.11 of the Local Government Act 1995) is for a maximum of two years, concluding at each ordinary local government election, it is opportune to review the committees and working groups and their associated Terms of Reference for relevance and purpose(s).

The Local Government Act 1995 allows for committees to comprise a mix of:

- Elected members
- Employees
- Other persons.

Depending on the intended purpose of the committee, its composition may be restricted or have other rights, impacts and obligations.

The committees and reference groups proposed comprise of elected members and other persons as voting members only. The attendance of certain staff may be required for advice and support etc, but they generally should not have voting membership (in the opinion of the Administration).

The Terms of Reference provide for participation in the committee or reference group:

- by a representative of a specified organisation, and
- by members of the community at large, upon their application, and appointed by name by Council.

It is not uncommon to have members of the public with relevant experience as a member of the Audit Committee, but it is not required.

There is no legislative power for any committee or reference group to "co-opt" a person as a voting member, but may invite a person to speak or present to a meeting on a matter.

Only those members of a committee or reference group as appointed by Council may move, second, vote or have a right to speak. Only a deputy appointed by Council may act as a member of a committee, if the person they are the appointed deputy for is absent for the whole of the meeting.

Legislation generally provides that:

- the Shire President may exercise a right to be a member of any committee, ex-officio
- the committee itself is to elect its presiding person and deputy
- if an employee is to be a voting member of a Committee the CEO has the right to be that employee, ex-officio, or to nominate a specific employee to be a member.

Establishment of a committee, determination of membership and terms of reference is required to be by absolute majority.

Changes to a committee or reference group terms of reference or establishment may be made at any time by Council resolution.

The Administration proposes retaining all current existing advisory committees and reference groups and altering, slightly, the terms of reference of the Townscape Advisory Committee (to meet every two months, as opposed to every six weeks), the Australia Day & Honours Advisory Committee (replacing reference of the non-operating Ratepayers & Residents Association with the Narrogin Chamber of Commerce) and Community Chest Reference Group (dealing with guiding the Community Chest Grant Guidelines), as detailed in the attachment.

Review of the previous two years' agendas for the Townscape Advisory Committee, would indicate that the volume or timing of items only requires committee consideration or recommendation to warrant a frequency of bimonthly, or more often, if required.

Consultation

The Executive Management Team was consulted as to the make-up, functionality and frequency of the various Committees and Reference Groups.

Statutory Environment

Local Government Act 1995:

- Sections 5.8, 5.9, 5.10 and 5.11 – establishment and composition of committees
- Section 7.1A – requirement to establish an audit committee.

Emergency Management Act 2005 Section 38.

Unlike the requirement for the Council to appoint an Audit Committee and Emergency Management Committee, the Bushfires Act 1954, Section 67, provides that a Council may appoint a Bushfire Advisory Committee. Continuation of this important committee is recommended.

Policy Implications

Nil

Financial Implications

There are no relevant financial implications other than administrative.

This Council in its Annual Budget has elected to pay Elected Members an allowance annuity (paid quarterly in arrears) for attending Council and Committee Meetings (regardless of how many).

It should be noted however, that community members are not entitled to a meeting fee under the Local Government Act 1995 or Local Government Chief Executive Officers and Elected Members Determination No 1 of 2021.

Strategic Implications

Shire of Narrogin Strategic Community Plan 2017-2027		
Objective	2.	Social Objective (To provide community facilities and promote social interaction)
Outcome:	2.3	Existing strong community spirit and pride is fostered, promoted and encouraged
Strategy:	2.3.2	Engage and support community groups and volunteers

Objective	4.	Civic Leadership Objective (Continually enhance the Shire's organisational capacity to service the needs of a growing community)
Outcome:	4.1	An efficient and effective organisation
Strategy:	4.1.1	Continually improve operational efficiencies and provide effective services
Strategy:	4.1.2	Continue to enhance communication and transparency

Voting Requirements

Absolute Majority

OFFICERS' RECOMMENDATION AND COUNCIL RESOLUTION 1021.010

Moved: Cr Pomykala

Seconded: Cr Early

That with respect to Council Committees, Reference Groups, and dealing with Council Member, Committee Member or Candidate Code of Conduct Complaints, Council establish the following Committee and Working Groups and adopt the Terms of Reference and Standard Conditions as presented in Attachment 1.

1. Advisory Committees

- a. Audit Advisory Committee;
- b. Airport Advisory Committee;
- c. Local Emergency Management Committee;
- d. Australia Day and Honours Advisory Committee;
- e. Bush Fire Advisory Committee; and
- f. Townscape Advisory Committee.

2. Reference Groups

- a. Community Assisted Transport (CATS) Stakeholder Reference Group;
- b. Community Chest Grants Reference Group; and
- c. Roads Reference Group.

3. Council Member, Committee Member and Candidate Code of Conduct Complaints Authorisations.

**CARRIED 9/0
BY ABSOLUTE MAJORITY**



COUNCIL COMMITTEES and REFERENCE GROUPS

Establishment & Terms of Reference

Re-established 23 October 2019

(as at 11 March 2021)

[Proposed amendments October 2021](#)

History Summary

Item	Date	Action	Description
1	25 October 2016	Adopted	Resolution of Council 1016.166
2	20 December 2016	Amendment	Resolution of Council 1216.197 Terms of Reference for Australia Day & Honours Committee Changes incorporated: – <ul style="list-style-type: none"> - changes to title of the Awards throughout; - an additional category, to be consistent with the State Awards; and - reference to place of residence being removed as a criterion for nomination.
3	22 March 2017	New	Resolution of Council 0317.027 Adoption of Terms of Reference for establishment of Roads Reference Group.
4	27 September 2017	Amendment	Resolution of Council 0917.108 Amendment to Narrogin Airport Committee Membership
5	25 October 2017	Amendment	Resolution of Council 1017.123 Community Chest Reference Group and road Reference Group – no voting rights to Shire staff. Appointment of various delegates and Committee members and revocation of all previous appointments including those appointed pursuant to resolution 0917.108
6	26 September 2018	Amendment	Resolution of Council 0918.087 The Senior Officer responsible is changed from the Manager Leisure and Culture, to the Executive Manager Development and Regulatory Services.
7	28 November 2018	Amendment	Resolution of Council 1118.116 Narrogin Airport Committee – inclusion of Narrogin Gliding Club, Narrogin Flying Club, St John Ambulance to Committee Membership.
8	19 December 2018	Amendment	Resolution of Council 1218.128 Responsible Officer changed to Executive Manager DRS, Schedule 1.4 changes to advertising and nomination periods, Increase committee membership from 5 to 8, Increase quorum from 3 to 4, Increase community members from 0 to 3.
9	23 October 2019	Re-established	Resolution of Council 1019.012 Review and re-establishment of Committees in accordance with Local Government Act 1995 section 5.8 and re-appointment of members s.5.10 and 5.11, Bush Fires Act 1954, section 67 and Emergency Management Act 2005, section 38.
10	28 November 2019	Amendment	Resolution of Council 1119.017 Australia Day & Honours Committee clause 11e changed from: <i>Unsuccessful nominees may be re-nominated in future</i>

Item	Date	Action	Description
			<i>years; to read as: Unsuccessful nominees may be either recommended and / or re-considered in future years.</i>
11	25 March 2020	Amendment	Resolution of Council 0320.010 Townscape Advisory Committee – Role and Scope point 4 changed from “quarterly” meetings to “every six weeks”.
12	23 June 2020	Amendment	Resolution 0220.010 Community Chest Reference Group to include assessment of Landcare applications for recommendation to Council.
13	23 June 2020	Amendment	Resolution of Council 0420.010 (Part 7) Expand membership of LEMC to include a representative of the Dept. of Education.
14	30 September 2020	Amendment	Resolution of Council 0720.003 Townscape Advisory Committee – new role and scope, point 5, the Committee is to make recommendations to Council to applications for grants made by businesses pursuant to the Colour Palette and Sign Guide (CBD) Policy.
15	11 March 2021	New Committee of Council	Resolution of Council 0221.016 New Code of Conduct for Council Members, Committee Members and Employees – New Conduct Complaints Committee.
16	11 March 2021	Edited Appendix 1	Resolution of Council 0221.016 Replaced reference to the former Code of Conduct with the new Code of Conduct.

CONTENTS

History Summary

Section 1 - Committees of Council

- 1.1 Audit Advisory Committee
 - TOR Schedule 1.1 – Risk Management
- 1.2 Airport Advisory Committee
- 1.3 Local Emergency Management Committee
- 1.4 Australia Day and Honours Advisory Committee
 - TOR Schedule 1.4 – Honours and Awards Processes and Criteria
- 1.5 Townscape Advisory Committee
- 1.6 Bush Fire Advisory Committee
- 1.7 Code of Conduct Complaints Committee

Section 2 - Reference Groups

- 2.1 Community Assisted Transport Service (CATS) Stakeholder Reference Group
- 2.2 Community Chest Grants Reference Group
- 2.3 Roads Reference Group

Appendices

- Appendix 1 – Standard conditions for establishment of Council Committees
- Appendix 2 – Criteria for community members of Council Committees and Groups
- Appendix 3 – Other Shire established groups

Section 1 - Committees of Council

1.1 Audit Advisory Committee

Statutory context	Local Government Act 1995 – <ul style="list-style-type: none">• Part 7 – Audit Local Government (Audit) Regulations 1996 Appendix 1 – Standard conditions for establishment of Council Committees
Council context	Appendix 1 – Standard conditions for establishment of Council Committees
History	Established 25 October 2016 Reviewed 23 October 2019

Establishment

Objectives To exercise responsibility for the annual external audit and liaise with the local government's auditor so that Council can be satisfied with the performance of the local government in managing its financial affairs.

To assist Council in discharging its legislative responsibilities of controlling the local government's affairs, determining the local government's policies and overseeing the allocation of the local government's finances and resources.

To ensure openness in the local government's financial reporting and will liaise with the CEO to ensure the effective and efficient management of local government's financial accounting systems and compliance with legislation.

To facilitate –

- the enhancement and objectivity of internal and external financial reporting;
- effective management of financial and other risks and the protection of assets;
- compliance with laws and regulations as well as best practice in auditing;
- the coordination of the internal audit function with the external audit;
- the effective communication between the auditor, the CEO and the Council.

Membership

Composition resolved by Council		
Nomination of	No.	
Elected members, including ex-officio	9	
Employees, including ex-officio	0	
Other persons – Community at large	0	
- Specified organisations	0	
Total Membership	9	
Quorum	5	No additional criteria

Required staff attendance (non-voting) –

Primary	Secondary
Chief Executive Officer	
Exec. Manager Corporate & Community Services	Manager Finance <u>Corporate Services</u>

Meetings Appendix 1 – Standard conditions for establishment of Council Committees

Administrative Support

Senior Officer responsible	Executive Manager Corporate & Community Services
Initial contact person	Executive Manager Corporate & Community Services

Role and Scope of Committee

1. Audit –
 - a) Provide guidance and assistance to Council as to the carrying out the functions of the local government in relation to audits.
 - b) Develop and recommend to Council an appropriate process for the selection and appointment of a person as the local government’s auditor.
 - c) Develop and recommend to Council –
 - a list of those matters to be audited; and
 - the scope of the audit to be undertaken.
 - d) Recommend to Council the person or persons to be appointed as auditor.
 - e) Develop and recommend to Council a written agreement for the appointment of the auditor, which is to include –
 - the objectives of the audit;
 - the scope of the audit;
 - a plan of the audit;
 - details of the remuneration and expenses to be paid to the auditor; and
 - method/s to be used by the local government to communicate with, and supply information to, the auditor.
 - f) Meet with the auditor once in each year and provide a report to Council on the matters discussed and outcome of those discussions.
 - g) Liaise with the CEO to ensure that the local government does everything in its power to –
 - assist the auditor to conduct the audit and carry out his or her other duties under the Local Government Act 1995; and
 - ensure that audits are conducted successfully and expeditiously.
 - h) Examine the reports of the auditor after receiving a report from the CEO on the matters and –
 - determine if any matters raised require action to be taken by the local government; and
 - ensure that appropriate action is taken in respect of those matters.
 - i) Review the report prepared by the CEO on any actions taken in respect of any matters raised in the report of the auditor and presenting the report to Council for adoption prior to the end of the next financial year or 6 months after the last report prepared by the auditor is received, whichever is the latest in time.
 - j) Review the scope of the audit plan and program and its effectiveness.
 - k) Review the local government’s draft annual financial report, focusing on:
 - accounting policies and practices;
 - changes to accounting policies and practices;
 - the process used in making significant accounting estimates;
 - significant adjustments to the financial report (if any) arising from the audit process;
 - compliance with accounting standards and other reporting requirements;
 - significant variances from prior years.

- l) Consider and recommend adoption of the annual financial report to Council. Review any significant changes that may arise subsequent to any such recommendation but before the annual financial report is signed.
 - m) Address issues brought to the attention of the committee, including responding to requests from Council for advice that are within the parameters of the committee's terms of reference.
 - n) Seek information or obtain expert advice through the CEO on matters of concern within the scope of the committee's terms of reference following authorisation from the Council.
 - o) Review the Statutory Compliance Return and make a recommendation on its adoption to Council.
2. Risk Management –
- a) Oversight in the areas of risk management, internal control and legislative compliance in accordance with the Local Government (Audit) Regulations 1996 r.17.
 - b) Consider, approve and review the annual Internal Audit Plan
 - c) Advise Council on performance against the adopted Internal Audit Plan.
3. CEO support and advice –
- a) Provide the CEO with interim advice of a complex or confidential nature on request by the CEO.

– End of TOR

Notes

Reg. 17 Plan to be developed by EMCCS
Frequency – minimum two per annum, more as required.

TOR Schedule 1.1 – Risk Management

AUDIT ADVISORY COMMITTEE INTERNAL RISK MANAGEMENT REVIEW REPORT

Report prepared by **Executive Manager Corporate & Community Service**

Rating key: **A:** Acceptable **I:** Improvement required. **U:** Unacceptable, requires attention.

1. RISK MANAGEMENT			
a) The following considerations were based on the Department of Local Government & Communities Operational Guideline, No.09 dated September 2013:			
Considerations	Rating	Observation	Strategies
(1) Reviewing whether the local government has an effective risk management system and that material operating risks to the local government are appropriately considered.		•	Action required: •
(2) Reviewing whether the local government has a current and effective business continuity plan (including disaster recovery) which is tested from time to time.		•	Action required: •
(3) Assessing the internal processes for determining and managing material operating risks in accordance with the local government's identified tolerance for risk, particularly in the following areas: (a) potential non-compliance with legislation, regulations and standards and local government's policies; (b) important accounting judgements or estimates that prove to be wrong; (c) litigation and claims (d) misconduct, fraud and theft (e) significant business risks, recognising responsibility for general or specific risk areas, for example, environmental risk, occupational health and safety, and how they are managed by the local government.		•	Action required: •
(4) Obtaining regular risk reports, which identify key risks, the status and the effectiveness of the risk management systems, to ensure that identified risks are monitored and new risks are identified, mitigated and reported.		•	Action required: •
(5) Assessing the adequacy of local government processes to manage insurable risks and ensure the adequacy of insurance cover, and if applicable, the level of self-insurance.		•	Action required: •
(6) Reviewing the effectiveness of the local government's internal control system with management and the internal and external auditors.		•	Action required: •

(7) Assessing whether management has controls in place for unusual types of transactions and/or any potential transactions that might carry more than an acceptable degree of risk.		•	Action required: •
(8) Assessing the local government's procurement framework with a focus on the probity and transparency of policies, procedures & processes and whether these are being applied.		•	Action required: •
(9) Should the need arise, meeting periodically with key management, internal and external auditors, and compliance staff, to understand and discuss any changes in the local government's control environment.		•	Action required: •
(10) Ascertaining whether fraud and misconduct risks have been identified, analysed, evaluated, have an appropriate treatment plan which has been implemented, communicated, monitored and there is regular reporting and ongoing management of fraud and misconduct risks.		•	Action required: •]

2. INTERNAL CONTROL			
<p>a) Internal Control is a key component of a sound governance framework, in addition to leadership, long-term planning, compliance, resource allocation, accountability and transparency.</p> <p>b) Internal control systems involve policies and procedures that safeguard assets, ensure accurate and reliable financial reporting, promote compliance with legislation and achieve effective and efficient operations and may vary depending on the size and nature of the local government.</p> <p>c) Strategies to maintain sound internal controls are based on risk analysis of the internal operations of a local government.</p>			
<p>(1) Management Practices:</p> <p>(a) Separation of roles and functions, processing and authorisation:</p> <p>(i) integrity and ethics;</p> <p>(ii) documented policies & procedures, delegated authority, levels of responsibilities and authorities;</p> <p>(iii) audit practices;</p> <p>(b) Management operating style.</p> <p>(c) Human Resource management and practices:</p> <p>(i) volunteer management</p> <p>(ii) trained and qualified employees; and</p> <p>(iii) equity and diversity leadership.</p> <p>(d) HR Systems Control:</p> <p>(i) Induction Programs</p> <p>(ii) Recruitment</p> <p>(iii) Training</p> <p>(iv) Performance Management</p>		•	Action required: •

<p>(2) Information Management:</p> <p>(a) Data Management: Comparison of internal data with other or external sources of information, for example:</p> <p>(i) Geographical Information Systems (GIS); and</p> <p>(ii) Public Works Engineering Data (e.g.: <i>As constructed data</i>).</p> <p>(b) Control of approval of correspondence (documents, letters); and</p> <p>(c) Systems control: Security access, approval, version control.</p>		<ul style="list-style-type: none"> • 	<p>Action required:</p> <ul style="list-style-type: none"> •
<p>(3) Physical and Information Security: information system access and security, for example:</p> <p>(a) limitations on direct physical access to assets and records;</p> <p>(b) control of computer applications and information system standards;</p> <p>(c) limitations on access to make changes in data files and systems; and</p> <p>(d) testing the arithmetical accuracy and content of records.</p>		<ul style="list-style-type: none"> • 	<p>Action required:</p> <ul style="list-style-type: none"> •
<p>(4) Financial Management: integrity of financial systems, processes, controls, auditing, for example:</p> <p>(a) approval of financial transactions (records);</p> <p>(b) regular maintenance and review of financial control accounts and trial balances;</p> <p>(c) comparison and analysis of financial results with budgeted amounts;</p> <p>(d) report, review and approval of financial payments and reconciliations; and</p> <p>(e) comparison of the result of physical cash and inventory counts with accounting records.</p>		<ul style="list-style-type: none"> • 	<p>Action required:</p> <ul style="list-style-type: none"> •

3. LEGISLATIVE COMPLIANCE
 Local governments are required by legislation to complete a statutory compliance return (Compliance Audit Return or CAR) annually and have the return adopted by Council. The return is a checklist of a local government’s compliance with the requirements of the Act and its Regulations, concentrating on areas of compliance considered “high risk

<p>Legislative Compliance:</p> <p>(a) Statutory reporting timeframes are met;</p> <p>(b) Council and Executive Policy Positions are relevant and can be complied with;</p> <p>(c) Delegations are legislatively compliant, understood and complied with.</p>		<ul style="list-style-type: none"> • 	<p>Action required:</p> <ul style="list-style-type: none"> •
---	--	---	--

– End of Schedule

1.2 Airport Advisory Committee

Statutory context Appendix 1 – Standard conditions for establishment of Council Committees

Council context Appendix 1 – Standard conditions for establishment of Council Committees

History

Established	25 October 2016
Amendment	27 September 2017
Amendment	25 October 2017
Updated	28 November 2018
Reviewed	23 October 2019

Establishment

Objectives To advise Council on –

- airport development
- airport services
- airport infrastructure
- user and lessee management

Membership

Composition resolved by Council	
Nomination of	No.
Elected members, including ex-officio	4
Employees, including ex-officio	0
Other persons – Community at large	0
- Specified organisations	
Narrogin Gliding Club	1
Narrogin Flying Club	1
St John Ambulance	1
	7
Quorum	4

Required staff attendance (non-voting) –

Primary	Secondary
Exec Manager Technical & Rural Services	
Manager Operations	

Meetings Appendix 1 – Standard conditions for establishment of Council Committees

Committee's Administrative Support

Senior Officer responsible	Executive Manager Technical & Rural Services
Initial contact person	Executive Support Officer Technical & Rural Services

Role and Scope of Committee

1. To investigate, plan and report on options and proposals for airport development and expansion.
2. To review existing services (user access, navigation, emergency response etc.) and ensure highest practicable standard is maintained.
3. To monitor the physical infrastructure (runway, buildings, fencing, equipment etc.).
4. To provide a further avenue of communication and consultation between Council, users and lessees of land, or buildings, and advise Council on the management of facilities.

– End of TOR

Notes

1.3 Local Emergency Management Committee

Statutory context	Emergency Management Act 2005						
	Emergency Management Regulations 2006						
	State Emergency Management Directions						
	Appendix 1 – Standard conditions for establishment of Council Committees						
Council context	Appendix 1 – Standard conditions for establishment of Council Committees						
History	<table border="0"> <tr> <td>Established</td> <td>25 October 2016</td> </tr> <tr> <td>Reviewed</td> <td>23 October 2019</td> </tr> <tr> <td>Amended</td> <td>23 June 2020</td> </tr> </table>	Established	25 October 2016	Reviewed	23 October 2019	Amended	23 June 2020
Established	25 October 2016						
Reviewed	23 October 2019						
Amended	23 June 2020						

Establishment

Objectives To prepare and continuously monitor and review the Local Emergency Management arrangements for the Shire of Narrogin

Membership

Maximum membership of not more than 15, principally being the primary responders to any emergency. Others welcome to attend as Observers and to participate with the consent of the presiding person.

Composition resolved by Council		
Nomination of	No.	
Council members, including ex-officio	2	Committee Chairperson to be Cr.....
Employees, including ex-officio	0	
Other persons – Community at large	0	
- WA Police, OIC Narrogin	1	ex-officio – LEM Coordinator
- DFES, Narrogin Regional Officer	1	
- Narrogin Regional Hospital	1	
- Narrogin Volunteer Bush Fire Brigades	1	Chief BFCO or DCBFCO
- Narrogin VFRS Unit	1	
- Narrogin SES Unit	1	
- Water Corporation	1	
- Western Power, Narrogin	1	
- Dept of Communities Dept of Child Protection & Family Support	1	
- Dept of Primary Industry & Regional Development Dept of Agriculture and Food WA	1	
- Dept of Biodiversity, Conservation & Attractions - Parks & Wildlife Services Dept of Parks & Wildlife	1	
- Narrogin St John Ambulance Sub-centre	1	

- Dept of Education	1	
Total Membership	15	
Quorum	8	No additional criteria

Observers to be invited (non-voting) –

Organisation	Position
- Narrogin District Education Office	
- Main Roads WA, Narrogin	
- Great Southern SEMC Executive	
- YMCA Narrogin	
- Karinya Cottage Homes	
- Narrogin Home Care	
- Housing Authority	
- Salvation Army, Narrogin	
- Disability Services Commission	

Required staff attendance (non-voting) –

Primary	Secondary
Executive Manager Development & Regulatory Services	Executive Manager Technical & Rural Services
Senior Ranger	
Admin Officer, Em Mgmt	Admin Officer, Devt & Reg Serv

Meetings Appendix 1 – Standard conditions for establishment of Council Committees
Other than Presiding Member,

Presiding Member The EM Act s.38 specifies that the Chair is determined by the local government.

Administrative Support

Senior Officer responsible	Executive Manager Development & Regulatory Services
Initial contact person	Administration Officer, Local Emergency Management

Role and Scope of Committee

1. In accordance with Emergency Management Act s.38(2) the specified area of responsibility is the whole of the Shire of Narrogin.
2. To identify emergency risks or hazards in the community and arrange to establish, maintain and test the Local Emergency Management Arrangements established to mitigate the risks or hazards.
3. To encourage and maintain communication and joint exercises between all stakeholders.
4. To prepare and instil prevention, preparedness, response and recovery plans for a variety of identified risks or hazards preventing or minimising the effects of emergency events.
5. To increase the number and relative awareness of programmes through community awareness campaigns designed to make the community more resilient.

6. To undertake the Community Emergency Risk Management process.
7. To carry out other emergency management activities as directed by the State Emergency Management Committee or prescribed in the Emergency Management Regulations 2006.
8. To prepare and submit each financial year an annual report of its activities in accordance with the requirements of the State Emergency Management Committee.
9. To prepare an annual business plan in accordance with the requirements of the State Emergency Management Committee.
10. The Local Emergency Management Committee does not have the authority or power to commit the Shire of Narrogin to expenditure without the Shire's endorsement.

– End of TOR

Notes

The Committee does not have any operational authority for emergency events.

1.4 Australia Day and Honours Advisory Committee

Statutory context Appendix 1 – Standard conditions for establishment of Council Committees

Council context Appendix 1 – Standard conditions for establishment of Council Committees

History

Established	25 October 2016
Amended	20 December 2016
Amended	19 December 2018
Reviewed	23 October 2019

Establishment

Objectives To provide an avenue of communication/consultation between Council and the community for –

- Australia Day WA Citizen of the Year Awards; in each category determined by it;
- Shire of Narrogin Australia Day Awards; consistent with the Australia Day WA Citizen of the Year Awards eligibility criteria and such other local award deemed appropriate by the Shire;
- Shire of Narrogin Australia Day functions and events; and
- other Commonwealth, State or local awards or honours.

Membership

Composition resolved by Council	
Nomination of	No.
Elected members, including ex-officio	2
Employees, including ex-officio	0
Other persons – Community at large	3
- Lions, Narrogin	1
- Rotary, Narrogin	1
- Narrogin Residents & Ratepayers Assoc.	1
Total Membership	87
Quorum	4
	No additional criteria

Required staff attendance (non-voting) –

Primary	Secondary
Executive Manager Development & Regulatory Services	

Meetings Appendix 1 – Standard conditions for establishment of Council Committees

Administrative Support

Senior Officer responsible	Executive Manager Development & Regulatory Services
Initial contact person	Admin Support Officer, Development & Regulatory Services

Role and Scope of Committee

1. To promote the Australia Day, Australia Day WA Citizen of the Year Awards and Shire of Narrogin Australia Day Awards and make recommendations to Council based on nominations received from the community.
2. To recommend to Council nomination of community members for recognition in –
 - Australian Honours,
 - National or State Australia Day Awards,
 - Other recognition or honours considered appropriate
3. To consider community requests for Council support of nominations for Commonwealth or State awards or honours.
4. To promote the Shire's Australia Day event within the wider community with due consideration and respect for the needs and views of all members of the community.
5. To give consideration to; and make decisions regarding the venue, program/format, menu and layout of tables/seating and decorations.

– End of TOR

Notes

TOR Schedule 1.4 – Honours and Awards Processes and Criteria

1. The Australia Day WA Citizen of the Year Awards foster, recognise and celebrate significant contributions to community life and active citizenship in Shire of Narrogin in the following categories –
 - a) Citizen of the Year
 - b) Citizen of the Year (Youth)
 - c) Citizen of the Year (Senior)
 - d) Active Citizenship (Group or Event)
2. The Committee is to coordinate and consider –
 - a) community nominations for the Australia Day WA Citizen of the Year Awards;
 - b) Shire of Narrogin Awards consistent with the Australia Day Citizen of the Year Awards, and in exceptional circumstances, -other recognition as appropriate; and
 - c) in exceptional circumstances, any other Commonwealth, State or local award or honours.
3. The Shire will invite Australia Day WA Citizen of the Year Awards nominations from community groups and private citizens.
4. Australia Day WA Citizen of the Year Awards nominations will open on 1 September and close on 31 October.
5. Australia Day WA Citizen of the Year Awards nominations will be advertised –
 - a) in the Narrogin Observer in mid-August and again in mid-September, and
 - b) on the Shire's website and Facebook page
6. Late nominations for Awards will not be accepted.
7. Award recipients will be considered by the Australia Day and Honours Committee.
8. The Committee is to make its recommendations to the Council Meeting held in November whose decision will be final.
9. Nomination forms are to have a nominator as well as another person to support the nomination;
10. The award recipients will be judged to have shown active citizenship and –
 - a) Made significant contribution to the local community.
 - b) Demonstrated leadership on a community issue resulting in the enhancement of community life.
 - c) Made a significant initiative which has brought about positive change and added value to community life.
 - d) Demonstrated inspiring qualities as a role model for the community.
11. Eligibility Criteria –
 - a) A person who does not reside ~~within the~~within the Shire of Narrogin is eligible to ~~receive an~~receive award
 - b) Awards may be granted posthumously in recognition of recent achievements.
 - c) Groups of people will not normally be eligible except when meeting the criteria for a community group.
 - d) A person cannot receive the same award ~~twice, but~~twice but can be considered for another award.
 - e) Unsuccessful nominees may be either recommended and / or re-considered in future years.
 - a) Self-nominations are not eligible.
 - b) Sitting members and employees of Commonwealth, State and Local Government are not eligible for nomination relating to their service as an elected member or ~~employee, but~~employee but may be considered for nomination in their private capacity.
12. Awards will be presented at the Australia Day Community Event on 26 January annually.
13. Awards and Honours other than Australia Day WA Citizen of the Year Awards may be considered by the Committee at any time throughout the year, following the general principles and procedures above, for presentation at an appropriate function.

1.5 Townscape Advisory Committee

Statutory context Appendix 1 – Standard conditions for establishment of Council Committees

Council context Appendix 1 – Standard conditions for establishment of Council Committees

History	Established	25 October 2016
	Amended	26 September 2018
	Reviewed	23 October 2019
	Amended	24 March 2020
	Amended	28 July 2020

Establishment

Objectives To recommend to Council proposals to improve the physical infrastructure of the Narrogin and Highbury townsites, and throughout the district with a specific focus on:

- aesthetic presentation of the area,
- access and facilities for elderly and people with disabilities,
- designing out crime or anti-social behaviours.

Membership

Composition resolved by Council		
Nomination of	No.	
Elected members, including ex-officio	2	
Employees, including ex-officio	0	
Other persons – Community <ul style="list-style-type: none"> ○ at large 	4	Specific interest to be sought – <ul style="list-style-type: none"> ○ Indigenous representative (1) ○ Expertise in disability or aged sectors (1)
- Highbury District Community Council	1	
- Narrogin Chamber of Commerce	1	
- Arts Narrogin	1	
Total Membership	9	
Quorum	5	Quorum reduced to 4 if one or more vacancies exist in Committee membership, for the period of any vacancy only.

Required staff attendance (non-voting) –

Primary	Secondary
Executive Manager Technical & Rural Services	

Meetings Appendix 1 – Standard conditions for establishment of Council Committees

Administrative Support

Senior Officer responsible	Executive Manager Technical & Rural Services
Initial contact person	Administration Support Officer, Development & Regulatory Services

Role and Scope of Committee

1. To make recommendations to Council for Budget purposes in relation to –
 - The adopted Townscape Plans for Highbury and Narrogin Townsites;
 - Disability and aged access to, and movement in, public facilities and places; and
 - Road Infrastructure design matters.
2. To advise Council on proposals referred to the Committee by the Administration concerning the impact on the character of the precinct, including its impact upon heritage structures, significant natural features and landmarks including, but not limited to –
 - a) The quality of architectural design including its relationship to the adjoining development;
 - b) The relationship with and impact on the broader public realm and streetscape;
3. To ensure that issues that are referred to the Committee by the Administration are given due consideration with respect to in planning, design, implementation and maintenance of the built and natural environment.
4. To meet every ~~six weeks~~ two months or more if required to deal with matters referred to it by the Administration.
5. To make recommendations to Council with respect to any applications for grants made by businesses pursuant to the Colour Palette and Sign Guide (CBD) Policy.

– End of TOR

Notes

- Local Government Act 1995 s.5.15 – Council may reduce quorum if there would not otherwise be a quorum –
- Regardless of number vacancies, quorum cannot be reduced to less than 4 without specific Council approval.

1.6 Bush Fire Advisory Committee

Statutory context Appendix 1 – Standard conditions for establishment of Council Committees

Council context Appendix 1 – Standard conditions for establishment of Council Committees

History

Established	23 October 2019
Amended	23 October 2019
Reviewed	23 October 2019

Establishment

Objectives To advise the local government regarding all matters relating to the preventing, controlling and extinguishing of bush fires, the planning of the layout of fire-breaks in the district, prosecutions for breaches of this Act, the formation of bush fire brigades and the grouping thereof under group brigade officers, the ensuring of co-operation and co-ordination of bush fire brigades in their efforts and activities, and any other matter relating to bush fire control whether of the same kind as, or a different kind from, those specified in this subsection.

Membership

Composition resolved by Council	
Nomination of	No.
Elected members, including ex-officio	1
Employees, including ex-officio	0
<ul style="list-style-type: none"> o Bush Fire Control Officers 	21
Total Membership	22
Quorum	12

Required staff attendance (non-voting) –

Primary	Secondary
Executive Manager Development & Regulatory Services	

Meetings Appendix 1 – Standard conditions for establishment of Council Committees

Administrative Support

Senior Officer responsible	Executive Manager Development & Regulatory Services
Initial contact person	Senior Ranger

Role and Scope of Committee

1. To advise the local government regarding all matters relating to the preventing, controlling and extinguishing of bush fires, the planning of the layout of fire-breaks in the district, prosecutions for breaches of this Act, the formation of bush fire brigades and the grouping thereof under group brigade officers, the ensuring of co-operation and co-ordination of bush fire brigades in their efforts and activities, and any other matter relating to bush fire control whether of the same kind as, or a different kind from, those specified in this subsection.

– End of TOR

Notes**BFAC**

Intended to hold two meetings annually –

- first – in March/April, to review the past fire season, consider Shire budget and ESL grant application, and
- second – in about September, to consider the coming season, any matters or preparations needed, recommendations regarding fire control officers, administrative arrangements etc

1.7 Code of Conduct Complaints ~~Committee~~Authorisations & Panel

Statutory context Local Government (Model Code of Conduct) Regulations 2021; Clause 11 (3), authorise the following persons to receive Division 3 complaints and withdrawals of same, relating to Council Members, Committee Members and Candidates (that become Council Members)

Appendix 1 – Standard conditions for establishment of Council Committees

Council context Appendix 1 – Standard conditions for establishment of Council Committees

History Established 24 February 2021

Establishment

Objectives Complaints regarding alleged breaches of the Model Code in Division 3 are managed by the local council as the decision-making body of the local governments. The division also provides a process for responding to alleged breaches. The emphasis is on education and development, rather than punitive sanctions, with the aim of establishing or restoring positive working relationships and avoiding further breaches. Failure to comply with this Division may give rise to a complaint regarding the conduct of a council member, committee member or candidate, which may lead to the council making a formal finding of a breach and requiring remedial action by the individual.

Membership

Composition resolved by Council		
Nomination of	No.	
The Shire President with respect to complaints made by anyone, excluding the Shire President;	1	
The Deputy Shire President with respect to complaints made by the Shire President, excluding those made about the Deputy Shire President;	1	
The Deputy Shire President with respect to complaints about the Shire President excluding those made by the Deputy Shire President; and	1	
A committee panel comprising all of the Council Members , excluding the Shire President and Deputy Shire President, with respect to complaints about the Deputy Shire President made by the Shire President. <u>Quorum: 4</u>	7	<u>Decisions to be made by a majority decision of the membership (ie 4)</u>
Total Membership		
Quorum	4	

Required staff attendance (non-voting) –

Primary	Secondary
Nil	

Meetings Appendix 1 – Standard conditions for establishment of Council Committees

Administrative Support

Senior Officer responsible	Nil <u>Chief Executive Officer</u>
Initial contact person	Nil <u>Chief Executive Officer</u>

Section 2 - Reference Groups

Reference Groups are not Committees of Council and exist as a forum to –

- advise staff,
- facilitate exchange of ideas and
- discuss the matters assigned.

Establishment of each Reference Group is similar to Council Committees for the sake of ~~consistency~~, ~~but consistency but~~ are not subject to the legislative constraints of a Committee. Where possible and appropriate, the Standard Conditions for Committees should be followed.

A Reference Group has no decision making authority whatsoever. Action may only be initiated within the scope of responsibility given to an officer of Council, or by a staff member following Council decision.

2.1 Community Assisted Transport Service (CATS) Stakeholder Reference Group

Statutory context Appendix 1 – Standard conditions for establishment of Council Committees

Council context Appendix 1 – Standard conditions for establishment of Council Committees

History Established 25 October 2016
Reviewed 23 October 2019

Establishment

Objectives A working group to provide advice regarding the management and coordination of the Community Assisted Transport Service.

Membership

Composition resolved by Council	
Nomination of	No.
Elected members, including ex-officio	1
Employees –	0
Other persons – Community at large	0
- Narrogin Lions Club (foundation member)	1
- Narrogin Revheads (foundation member)	1
- Shire of Wagin	1
- Shire of Cuballing	1
- Narrogin & District Senior Citizens	1
- Volunteer driver representative	1
Total Participation	7

Required staff attendance (non-voting) –

Primary	Secondary
Exec. Manager Corporate & Community Services	Manager Finance
Manager HomeCare	HomeCare Admin Supervisor

Administrative Support

Senior Officer responsible	Manager HomeCare
Initial contact person	Manager HomeCare

Role and Scope

1. To provide feedback and advice on the strategic direction to Council and relating to –
 - a) how to operate the CATS program in a more sustainable manner.
 - b) how to better promote the CATS program.
 - c) fee structure.
 - d) how to attract additional funding opportunities.
 - e) how to attract volunteers e.g. drivers/carers.
 - f) raising of issues regarding the service to clients by the stakeholders.
 - g) the type of motor vehicle to be used.
 - h) how to expand the CATS program.

- i) recommend an alternative management/ownership of the CATS program, if required.
2. To provide a further avenue of communication between Council and the community groups which operate or contribute to the Service.

– End of TOR

Notes

The CATS Stakeholder Reference Group membership was originally formed from the ongoing financial contributors and service providers to the CATS program. Membership was dependent on –

- continuing financial contributions of over \$1,000 per annum, and/or
- the provision of services to facilitate the service.

At Council meeting 25 October 2016, it was clarified that as foundation members, Narrogin Revheads and Narrogin Lions should remain permanent members of the Reference Group, without obligation to meet the contribution criteria.

2.2 Community Chest Grants Reference Group

Statutory context Appendix 1 – Standard conditions for establishment of Council Committees

Council context Appendix 1 – Standard conditions for establishment of Council Committees

History

Established	25 October 2016
Amended	25 October 2017
Reviewed	23 October 2019
Amended	23 June 2020

Establishment

Objectives A working group to review applications for Council assistance, prior to Officer's report to Council on suggested allocations from Budget.

Membership

Composition resolved by Council	
Nomination of	No.
Elected members, including ex-officio	3
Employees, including ex-officio	0
Other persons – Community at large	0
- Specific organisations	0
Total Participation	3

President
Elected Member x 23

Required staff attendance (non-voting) –

Primary	Secondary
Chief Executive Officer	Executive Manager Corporate & Community Services

Administrative Support

Senior Officer responsible	Chief Executive Officer
Initial contact person	Admin Support Officer, Development & Regulatory Services

Role and Scope of Committee

- To –
 - review applications from community groups for assistance from the annual Budget allocation made by Council;
 - review and assess applications for Landcare projects from the Landcare Reserve Fund;
 - b)c) to provide guidance to the Chief Executive Officer on the Grant & Acquittal Guidelines to be utilised by the Administration in marketing, promoting and conditions related to the grants; and
 - e)d) make recommendations to Council with respect to parts a) and b) through the Senior Officer responsible.

– End of TOR

2.3 Roads Reference Group

Statutory context Appendix 1 – Standard conditions for establishment of Council Committees and Reference Groups

Corporate context Appendix 1 – Standard conditions for establishment of Council Committees and Reference Group

History

Established	22 March 2017
Amended	25 October 2017
Reviewed	23 October 2019

Establishment

Objectives A working group to enhance communication between elected members and Technical & Rural Services staff –for

- information exchange
- discussion of technical issues.

Meeting frequency Quarterly –

- August – review roadworks program and recommended timetable
- November – progress review
- February – progress review, consider priorities for Budget consideration
- May – progress review, confirm Budget priorities for consideration

Membership

Composition resolved by Council		
Nomination of	No.	
Elected members	3	Elected members x 3
Employees, including ex-officio	0	
Other persons – Community at large	0	
- Specific organisations	0	
Total Participation	3	

Required staff attendance (non-voting) –

Primary	Secondary
Executive Manager Technical & Rural Services	
Manager Operations	
Technical Officer	

Administrative Support

Senior Officer responsible	Executive Manager Technical & Rural Services
Initial contact person	Technical Officer

Role and Scope

1. To –
 - a) review progression of the road works program;
 - b) ensure issues of concern to resident and users of the Shire's road network are discussed;
 - c) provide feedback regarding roadworks priorities for annual budget consideration;
 - d) consider priorities for roadworks consistent with Roads Asset Management Plan; and
 - e) make recommendations to Council through the Senior Officer responsible.
 - f) Consider requirements of Work Crew to implement road programs (plant).

– End of TOR

Appendices

Appendix 1 – Standard conditions for establishment of Council Committees

Unless otherwise specified in the establishment of a Committee or Reference Group, the following standard conditions apply to all.

Matters will only be listed if varying from these Standard Conditions

Statutory context	<p>The majority of Committees are established under the Local Government Act 1995 –</p> <ul style="list-style-type: none">- s.5.8 to s.5.18 – Committees and their meetings.- s.5.19 to s.5.25 – Matters affecting Council and Committee meetings.- s.5.59 to s.5.90 – Financial interests, declarations, gifts etc. <p>Also refer to Local Government (Administration) Regulations 1996 –</p> <ul style="list-style-type: none">- r.4 to r.14B – Committees and committee meetings. <p>Shire of Narrogin Meeting Procedures Local Law 2016, unless otherwise provided for by the Act or Regulations.</p> <p>Some committees, but not all, have statutory functions. If so, general references to legislative requirements are given.</p>
Council context	<p>From time to time, Council may adopt specific policies that affect the Committee or provide direction.</p> <p>Compliance with the Shire of Narrogin Code of Conduct for Council Members, Committee Members and Candidates is mandatory, as required by the Act and Regulations.</p>
History	<p>First established Last amended</p>
Establishment	
Objectives	<p>Brief outline of Council's objectives for the Committee.</p>
Authority	<p>Unless provided for by the Act or Regulations, the Committee has an advisory role only, and has no delegated authority to implement actions or activity unless authorised by Council.</p>
Financial Interests	<p>The Act requires all members of the Committee comply with the interest provisions of the Act –</p> <ul style="list-style-type: none">- financial – both direct and indirect interests which impact the member;- proximity – development adjoining or affecting the member;- declarations – written declaration to be made to CEO or presiding members;- gifts – to be notified to CEO within 10 days of receipt or promise of gift.
Working Parties	<p>The Act does not permit the establishment of a sub-Committee, however, the Committee may request that a member or several members consider a particular matter.</p>

Code of Conduct The Act requires compliance with the Code of Conduct for Council Members, Committee Members and Candidates adopted by the Shire of Narrogin.

Membership

Composition The Act requires that a Committee have a membership of at least 3 people.

A vacancy does not reduce the number of positions on the Committee, unless Council resolves by absolute majority. The number of members must be stipulated by Council, and cannot be varied by the Committee. Should there be less members than the number resolved by Council, the position is considered vacant, however, the quorum required is not affected.

The Committee is to comprise of –

- Council members, including ex-officio as permitted by the Act.
- Employees, as resolved by Council, including ex-officio as permitted by the Act. The role of member includes the obligation to vote and is separate from the administrative support function of the Committee.
- Other persons, i.e. community members, either named or by position within an external organisation.

If notified to Council when Committee is established, the President and CEO may exercise separate rights to be a member or nominate another elected member or employee to be a member of the Committee.

The TOR for a Committee does not over-ride a Council resolution.

Members	Council members	As stipulated in the resolution establishing the Committee by absolute majority, or subsequent decision, and including any ex-officio member.
	Employees	As stipulated in the resolution establishing the Committee by absolute majority, or subsequent decision, and including any ex-officio member.
	Other persons	From the community or specific organisation, as stipulated in the resolution establishing the Committee by absolute majority, or subsequent decision.

Only appointed members of a Committee may vote. Generally, staff will not be voting members of a Committee, but have an advisory and support role only. However, there may be exceptions and these will be noted in the individual Committee's Terms of Reference.

Nomination of a member may be –

- by name, in which case the person holds membership until removed, whether a resident, employee or not; or
- by position, in which case the person holding the specific position.

Where a member is appointed by position, a person acting in that position automatically has membership. If the person chooses to delegate the membership to another person within their organisation, this must be notified to the CEO. The person delegated does not automatically become the deputy member.

Deputy members The Act defines “deputy member” as a person appointed by Council authorised to act for a Committee member in that person’s unavailability.

Only the person initially present at the meeting may participate, i.e. “tag teaming” by leaving a meeting, allowing the other to participate and vote, is not permitted.

Where a deputy member is appointed by position, a person acting in that position automatically has membership. Where the person chooses to delegate the membership to another person within their organisation, this must be notified to the CEO.

Vacancies The Act requires that members and deputy members be approved by absolute majority of Council.

The Committee is not permitted to co-opt ~~members, but~~ members but may invite a person or organisation to make a presentation or deputation.

Tenure The Act stipulates membership of the Committee is until –

- the person no longer holds the office by virtue of which they were appointed,
- the person resigns by notice in writing to the presiding member or the CEO,
- the person’s term of appointment expires or is removed by Council, or otherwise become vacant,
- the committee is disbanded or term for which it was established expires.

Generally, Council will only appoint an elected member or community member to the same committee for a maximum of 3 consecutive terms (i.e. 6 years).

Consistent with the provisions of the Act s.2.25(4) applying to Council members, Council may remove a Committee member who has been absent for 3 consecutive meetings.

Payments Meeting fees are not paid. In some instances, reimbursement for actual expenses incurred in attending a Committee meeting may be permitted. Refer to CEO.

Meetings

Frequency May be specified by Council, but generally as required and determined by the Committee.

Presiding Member The Act requires that the presiding member be selected by the Committee.

Procedures In accordance with Shire of Narrogin Meeting Procedures Local Law.

Deputations In accordance with Shire of Narrogin Meeting Procedures Local Law.

Quorum The Act stipulates 50% of the designated membership of the Committee whether the position is vacant or not, must be present.

Where the membership is an odd number, the quorum is 50% and rounded up, e.g. quorum for a membership of 9 is 5.

In some circumstances, Council is permitted by absolute majority to give prior approval for a specific meeting to reduce the quorum required.

Voting	<p>All recommendations are to be by simple majority of Committee members present, The Presiding Members should announce the result of the vote, e.g. 3/1, or 4/0 etc..</p> <p>The Act requires that all Committee members present at the meeting –</p> <ul style="list-style-type: none"> • must vote, and • must vote in such a way that their vote is not secret, i.e. either on the voices or by show of hands. <p>Therefore the following are not permitted –</p> <ul style="list-style-type: none"> • proxy voting – submission of a written vote by another person); • abstaining from voting – those present are required by the Act to vote; • secret ballot or drawing of lots or similar. <p>In the case of equality of voting, the presiding member is to exercise a casting vote.</p> <p>Observers do not have a right to speak, but may address the meeting at discretion of the presiding member, and are not permitted to vote.</p>
Agendas	To be available 3 days prior to meeting, to Committee members and the public.
Minutes	To be available 5 days after the meeting to Committee members and the public. The Act requires that the minutes of Committee meetings are submitted to Council for noting and to the following Committee meeting for confirmation.
Recommendations	All decisions of the committee are recommendations to Council, and are not to be actioned until authorised by Council, unless the senior officer has existing authority, responsibility or discretion to do so.

Administrative Support

Senior Officer	<p>Has responsibility for the Committee, overseeing its general operation in accordance with these standard conditions or specific variation as authorised by Council, and ensuring the Committee's minutes are presented to Council.</p> <p>The role does not confer any right to vote.</p>
Contact	<p>Provides administrative support for the Committee at the direction of the senior office.</p> <p>The role does not confer any right to vote.</p>

Role and Scope of Committee

Detailed terms of reference will be given of what is expected of the Committee.

– End of Standard Conditions for TOR

Notes

General notes for guidance, not forming part of the establishment or terms of reference of the Committee.

TOR Schedule 0.1 – Title

Any Schedule will provide detailed instructions or guidance on how the role and responsibilities of the Committee are to be implemented.

– End of Schedule

Appendix 2 – Criteria for community members of Council Committees and Groups

A number of Committees have members from specific community organisations or from the community at large.

For these Committees, Council will seek to appoint community members so that the Committee meetings will consist of members and deputy members having –

- a) demonstrated expertise and knowledge in the particular area of Committee responsibility;
- b) relevant skills and experience to provide independent advice;
- c) current participation with an organisation having similar objectives would be well regarded,
- d) diverse backgrounds and experience, while remaining relevant to the Committee's functions.

Preference will be given to residents who have a detailed knowledge of the district, enabling Committee members to make a positive contribution towards the community.

Non-residents may be appointed by Council, if suitable candidates cannot be established from the community or if it is determined there is specific need or advisability.

Community members of specific organisations will be invited for –

- a) Local Emergency Management Committee
- b) Australia Day and Honours Advisory Committee
- c) Townscape Advisory Committee
- d) Community Assisted Transport Service Stakeholder Reference Group

In addition, community members at large will be sought for –

- a) Australia Day and Honours Advisory Committee
- b) Townscape Advisory Committee

Appendix 3 – Other Shire established groups

Although the following are groups established by the Shire, they do not report to Council but exist to support the function of

Occupational Health and Safety Committee

Responsible to – CEO

Established under the Occupational Safety and Health Act, the Committee is workplace based, with workplace representatives, is responsible to the employer (i.e. CEO), and has statutory obligations.

11.4.2 COUNCIL COMMITTEES AND REFERENCE GROUPS PARTICIPATION AND DELEGATES TO EXTERNAL ORGANISATIONS

File Reference	13.3.2 & 15.1.1
Disclosure of Interest	Neither the Author nor Authorising Officer have any Impartiality, Financial or Proximity Interests that requires disclosure.
Applicant	Shire of Narrogin
Previous Item Numbers	None
Date	13 October 2021
Author	Dale Stewart – Chief Executive Officer
Authorising Officer	Dale Stewart – Chief Executive Officer
Attachments 1. Council Committees and Reference Groups – Participation and Delegates to External Organisations (to Oct 2021)	

Summary

Council's consideration for membership of Council established Committees and Reference Groups and delegates to external organisations is requested.

Background

The Local Government Act 1995 and Emergency Management Act 2005 require the establishment of the following committees and specify some membership requirements:

- Audit Committee – must have a minimum of three council members, and the majority of the committee must be council members
- Local Emergency Management Committee – must include the local emergency management coordinator.

While other legislation does not specify a maximum tenure, the Local Government Act 1995 Section 5.11 stipulates that tenure of committee membership is only to the next local government ordinary elections (ie; a maximum of 2 years).

For consistency, it is suggested that all memberships be reviewed.

Comment

The Local Government Act allows for committees to comprise a mix of:

- Elected members
- Employees
- Other persons.

Depending on the intended purpose of the committee, its composition may be restricted or have other rights, impacts and obligations.

The committees and reference groups proposed comprise of elected members and other persons as voting members only. The attendance of certain staff may be required for advice and support etc, but they do not have voting membership.

The Terms of Reference provide for participation in several committees and reference groups –

- by a representative of a specified organisation, and
- by members of the community at large, upon their application, and appointed by name by Council.

It is not uncommon to have members of the public with relevant experience as a member of the Audit Committee, but it is not required.

The committees and reference groups proposed to include persons other elected members in their membership are:

- Airport Advisory Committee –
 - Specified organisations (3)
- Local Emergency Management Committee (LEMC) –
 - Specified organisations (13)
- Australia Day and Honours Advisory Committee –
 - Specified organisations (3)
 - Community at large (3)
- Townscape Advisory Committee –
 - Specified organisations (3)
 - Community (4) – two at large, two with special focus if possible
- Community Assisted Transport Service Stakeholder Reference Group –
 - Specified organisations (6)
- Bush Fire Advisory Committee (BFAC)
 - Bush Fire Control Officers.

There is no legislative power for any committee or reference group to “co-opt” a person as a voting member, but may invite a person to present to a meeting on a matter, or to speak to the matter with the consent of the presiding person.

Only those members of a committee or reference group as appointed by Council may move, second, vote or have a right to speak. Only a deputy appointed by Council may act as a member of a committee, if the person they are the appointed deputy for is absent for the whole of the meeting.

It is suggested that:

- each specified organisation be requested to confirm their representative to the relevant committee or reference group; and
- the community be invited to nominate for the Australia Day and Honours Committee and the Townscape Advisory Committee.

Appointment of members of a committee is required to be by absolute majority.

External organisations are those over which Council does not exercise control (establishment, dissolution etc). Appointment as a Council delegate to these organisations entitles the elected member to claim travel costs etc in accordance with adopted policy. A deputy delegate appointed may only claim travel if attending due to the absence of the delegate.

Appointment of delegates to Council reference groups and external organisations may be made by simple majority.

Changes to committee or reference group membership may be made at any time as a result of resignation, Council resolution etc.

Consultation

The Executive Management Team was consulted in the development of the Report.

Statutory Environment

- Local Government Act 1995 –
 - Sections 5.8 and 5.9 – establishment and composition of committees
 - Section 5.10 – appointment of committee members
 - Section 5.11A – deputy committee members
 - Section 5.11 – committee membership tenure
 - Section 7.1A – audit committee membership, excludes employees or representative of CEO
- Emergency Management Act 2005 Section 38 – membership to include local emergency coordinator.
- Bush Fires Act 1954 Section 67.

Policy Implications

Nil

Financial Implications

There are no relevant financial implications other than administrative.

This Council in its Annual Budget, has elected to pay Elected Members an allowance annuity (paid quarterly in arrears) for attending Council and Committee Meetings (regardless of how many).

It should be noted however, that community members are not entitled to a meeting fee under the Local Government Act 1995 or Local Government Chief Executive Officers and Elected Members Determination No 1 of 2021.

Strategic Implications

Shire of Narrogin Strategic Community Plan 2017-2027	
Objective	2. Social Objective (To provide community facilities and promote social interaction)
Outcome:	2.3 Existing strong community spirit and pride is fostered, promoted and encouraged
Strategy:	2.3.2 Engage and support community groups and volunteers
Objective	4. Civic Leadership Objective (Continually enhance the Shire's organisational capacity to service the needs of a growing community)
Outcome:	4.1 An efficient and effective organisation
Strategy:	4.1.1 Continually improve operational efficiencies and provide effective services
Strategy:	4.1.2 Continue to enhance communication and transparency

Voting Requirements

1. Simple Majority required for the procedural motions
2. Absolute Majority required for the committee delegate appointments.

OFFICERS' RECOMMENDATION AND COUNCIL RESOLUTION

PROCEDURAL MOTION

Moved: Cr Alexander

Seconded: Broad

That standing orders be suspended to enable discussion in relation to item 11.4.2.

CARRIED 9/0

OFFICERS' RECOMMENDATION AND COUNCIL RESOLUTION

PROCEDURAL MOTION

Moved: Cr Seale

Seconded: Cr Fisher

That standing orders be reinstated to enable a motion to be considered.

CARRIED 9/0

OFFICERS' RECOMMENDATION AND COUNCIL RESOLUTION 1021.011

Moved: Cr Seale

Seconded: Cr Early

That with respect to membership on Council Committees and Reference Groups and delegates to external organisations, Council:

1. Request the organisations as specified in the Committee and Reference Groups Establishment to confirm their desired continued participation and nominee;
2. Seek public applications for membership for the Australia Day and Honours Advisory Committee and Townscape Advisory Committee; and
3. Make the following appointments as members and deputy members of committees:

Committee	Member/s	Deputy/s
Audit Advisory Committee (9 elected members)	President L Ballard	n/a
	Cr T Alexander	
	Cr G Broad	
	Cr J Early	
	Cr M Fisher	
	Cr R McNab	
	Cr J Pomykala	
	Cr B Seale	
Airport Advisory Committee (4 elected members, 3 organisations)	President L Ballard	Cr Early
	Cr Wiese	n/a
	Cr Fisher	
	Cr Alexander	
	Narrogin Gliding Club	
	Narrogin Flying Club	
	St John Ambulance	
Local Emergency Management Committee (2 elected members, 12 organisations)	Cr Seale	President L Ballard
	Cr Broad	n/a
	WA Police OIC Narrogin <i>ex-officio (LEM Coordinator)</i>	
	Dept Fire & Emergency Services Narrogin Regional Officer	
	Narrogin Regional Hospital WACHS Operations Manager Southern Wheatbelt or delegate	
Narrogin Volunteer Bush Fire Brigades CBFCO or DCBFCO		

	Narrogin VFRS Unit Captain	
	Narrogin SES Unit Manager or delegate	
	Water Corporation	
	Western Power	
	Dept of Primary Industry & Regional Development	
	Dept of Biodiversity, Conservation & Attractions - Parks & Wildlife Services Regional Manager or delegate	
	Narrogin St John Ambulance Sub- Centre	
	Dept of Education	
Australia Day and Honours Advisory Committee (2 elected members, 3 organisations, 3 community at large)	Cr Early	Cr McNab
	President Ballard	Cr Fisher
	Narrogin Lions Club President or delegate	n/a
	Narrogin Rotary Club President or delegate	
	Narrogin Chamber of Commerce President or delegate	
	Community Member	
	Community Member	
	Community Member	
Townscape Advisory Committee (2 elected members, 3 organisations, 2 community at large, 2 community special focus)	Cr Pomykala	Cr Alexander
	Cr Early	
	Highbury District Community Council President or delegate	n/a
	Narrogin Chamber of Commerce Chairperson or delegate	
	Arts Narrogin Chair or delegate	
	Community Member	
	Community Member	
	Community Member (special focus)	

	Community Member (special focus)	
Bush Fire Advisory Committee (1 elected member, 21 Fire Control Officers)	President Ballard	Cr Seale
	All registered Fire Control Officers	n/a

4. Make the following appointments as members and deputy members of reference groups:

Reference Group	Member/s	Deputy/s
Community Assisted Transport Service (CATS) Stakeholder Reference Group (suggest 1 elected member)	Cr Broad	Cr Fisher
	Narrogin Lions Club	n/a
	Narrogin Revheads	
	Shire of Wagin	
	Shire of Cuballing	
	Narrogin & District Senior Citizens	
Volunteer driver representative		
Community Chest Grants Reference Group (suggest 3 elected members)	President Ballard	Cr Seale
	Cr Wiese	Cr McNab
	Cr Pomykala	
Roads Reference Group (suggest 3 elected members)	Cr Broad	Cr McNab
	Cr Wiese	
	Cr Fisher	

5. Make the following appointments as delegates and deputy delegates to external organisations;

External Organisation	Delegate/s	Deputy/s (if desired)
Development Advisory Panel must be elected members	President Ballard	Cr Seale
	Cr Broad	Cr Wiese
Central Country Zone WALGA must be elected members	President Ballard	Cr Wiese
	Cr Broad	
Wheatbelt South Regional Road Group (& Narrogin Sub-Group) must be elected members	Cr Broad	Cr Pomykala
	Cr Fisher	
Dryandra Country Visitors Centre	Cr Alexander	Cr Early

Narrogin Cottage Homes Committee	Cr Broad	Vacant
Regional Waste Management Group	President Ballard	Cr Early
Dryandra Voluntary Regional Organisation of Councils	President Ballard	Cr Fisher
District Health Advisory Committee (of WACHS)	Cr Alexander	Cr Seale
Narrogin Community Support Organisation	Cr Seale	Cr Alexander

**CARRIED 9/0
BY ABSOLUTE MAJORITY**



COUNCIL COMMITTEES REFERENCE GROUPS EXTERNAL ORGANISATIONS

Membership | Deputies | Representatives

To be read in conjunction with the Establishment and Terms of Reference

**All membership of committees prior to 2019 elections
are terminated, in accordance with
Local Government Act 1995 section 5.11**

History Summary

Date	Action	Description
25 October 2017	Adopted	Community Chest Reference Group and Roads Reference Group be altered, by only allowing voting rights for elected members, and not officers of the local government.
26 September 2018	Amended	Senior Officer Responsible Townscape Committee changed to Executive Manager Development & Regulatory Services.
13 December 2018	Amended	Resignation of G Ballard from Townscape Committee.
27 February 2019	Amended	Appointment of Ms G Kami and Mrs V Chadwick to Townscape Committee.
28 October 2019	Adopted	Res 1019.013 – Post election review and nomination of elected members to Committees, Reference Groups and external organisations.
20 December 2019	Amended	Res 1219.009 – Townscape Advisory Committee and Australia Day and Honours Advisory Committee membership updated.
3 August 2020	Amended	Cr Murray Fisher and Cr Brian Seale added to District Health Advisory Council of WA Country Health Service.
15 March 2021	Amended	Res 0221.016 New Committee – Code of Conduct Complaints Committee.

Council Committee Members & Deputy Members

Council committees are those where Council does exercise control (establishment, dissolution etc).

Appointed – 23 October 2019

Concluding – October 2021

Committee	Member/s	Deputy/s
Audit Advisory Committee (9 elected members)	President L Ballard	n/a
	Cr Wiese, Deputy President	
	Cr G Ballard	
	Cr Bartron	
	Cr Broad	
	Cr Early	
	Cr Fisher	
	Cr Lushey	
	Cr Seale	

Committee	Member/s	Deputy/s
Airport Advisory Committee (4 elected members, 3 organisations)	President L Ballard	Cr G Ballard
	Cr Lushey	
	Cr Wiese, Deputy President	
	Cr Fisher	
	Narrogin Gliding Club	n/a
	Narrogin Flying Club	
	St John Ambulance	

Committee	Member/s	Deputy/s
Local Emergency Management Committee (2 elected members, 12 organisations)	Cr Bartron	Cr Broad
	Cr Seale	
	WA Police – OIC Narrogin <i>ex-officio (LEM Coordinator)</i>	n/a
	Dept Fire & Emergency Services – Narrogin Regional Officer	
	Narrogin Regional Hospital – WACHS Operations Manager Southern Wheatbelt or delegate	
	Narrogin Volunteer Bush Fire Brigades – CBFCO or DCBFCO	
	Narrogin VFRS Unit – Captain	
	Narrogin SES Unit – Manager or delegate	
	Water Corporation	
	Western Power	
	Dept of Child Protection & Family Support	
	Dept of Agriculture & Food WA	
	Dept of Parks & Wildlife – Regional Manager or delegate	
Narrogin St John Ambulance Sub-Centre		

Committee	Member/s	Deputy/s
Australia Day and Honours Advisory Committee (2 elected members, 3 organisations, 3 community)	Cr Seale	Cr Fisher Cr Early
	President L Ballard	
	Narrogin Lions Club – President or delegate	n/a
	Narrogin Rotary Club – President or delegate	
	Narrogin Residents & Ratepayers Assoc – President or delegate	
	Community Member – Mrs M Atkins	
	Community Member – Mrs C Mahony	
Community Member – Mr L Riley		

Committee	Member/s	Deputy/s
Townscape Advisory Committee (2 elected members, 3 organisations, 2 community, 2 community special focus)	Cr Bartron	Cr Seale
	Cr Early	
	Highbury District Community Council – President or delegate	n/a
	Narrogin Chamber of Commerce – Chairperson or delegate	
	Arts Narrogin – Chair or delegate	
	Community Member – Ms G Kami	
	Community Member – Ms D Broad	
	Community Member (special focus – aged & disabled) – Mrs V Chadwick	
Community Member (special focus – indigenous)		

Committee	Member/s	Deputy/s
Bush Fire Advisory Committee (1 elected member, 21 Fire Control Officers)	President L Ballard	Cr Seale
	All registered Fire Control Officers	n/a

Committee	Member/s	Deputy/s
Code of Conduct Complaints Committee (All Elected Members – refer to Terms of Reference for Committee composition under complaint circumstances)	Shire President or	n/a
	Deputy Shire President or	n/a
	All remaining Elected Members excluding the Shire President and Deputy Shire President	n/a

Council Reference Groups

Reference groups are those where Council does exercise control (establishment, dissolution etc).

Appointed – 23 October 2019

Concluding – October 2021

Reference Group	Member/s	Deputy/s
Community Assisted Transport Service (CATS) Stakeholder Reference Group (1 elected member)	Cr Bartron	Cr Broad
	Narrogin Lions Club	n/a
	Narrogin Revheads	
	Shire of Wagin	
	Shire of Cuballing	
	Narrogin & District Senior Citizens	
	Volunteer driver representative	

Reference Group	Member/s	Deputy/s
Community Chest Grants Reference Group (3 elected members)	Cr Seale	Cr Lushey Cr Fisher
	Cr Wiese	
	President L Ballard	

Reference Group	Member/s	Deputy/s
Roads Reference Group (3 elected members)	Cr Wiese	Cr Fisher
	Cr Broad	
	Cr G Ballard	

External Organisations: Council Representatives & Deputy Representatives

External organisations are those where Council does not exercise control (establishment, dissolution etc).

Commencing - 23 October 2019

Concluding – October 2021

External Organisation	Delegate/s	Deputy/s
Development Advisory Panel must be elected member	President L Ballard Cr G Ballard	Cr Wiese Cr Seale
Central Country Zone WALGA must be elected member	President L Ballard Cr Wiese	Cr G Ballard
Wheatbelt South Regional Road Group (& Narrogin Sub-Group) must be elected member	Cr Broad President L Ballard	Cr Wiese
Dryandra Country Visitors Centre	Cr Seale	Cr Early
Narrogin Cottage Homes Committee	Cr Wiese	
Regional Waste Management Group	President L Ballard	Cr Fisher
Dryandra Voluntary Regional Organisation of Councils	President L Ballard	Cr Lushey
Narrogin Community Support Organisation	Cr Seale	
District Health Advisory Council (Southern)	Cr Fisher	Cr Seale

11.4.3 ORDINARY COUNCIL MEETING SCHEDULE

File Reference	13.3.8
Disclosure of Interest	Neither the Author nor Authorising Officer have any Impartiality, Financial or Proximity Interests that requires disclosure.
Applicant	Nil
Previous Item Numbers	Nil
Date	11 October 2021
Author	Dale Stewart – Chief Executive Officer
Authorising Officer	Dale Stewart – Chief Executive Officer
Attachments	Nil

Summary

Council is presented with the proposed Ordinary Council meeting dates for the 2022 calendar year as per the requirements of the Local Government (Administration) Regulations 1996.

Background

Each year, as per the requirements of the Regulations, Council is presented with the proposed meeting dates for the following calendar year so that advertising can occur to inform the residents and allow Councillors and staff to plan for the meetings.

Council currently meets on the fourth Wednesday of the month with the Ordinary Council meeting commencing at 7:00 pm, with a meal for Elected Members, the Executive Management Team and support staff required, commencing at 6:00 pm.

Consultation

The matter has been discussed with the Shire President and Elected Members prior to 16 October biennial election, however, has not been canvassed with the newly elected members.

The scheduling of dates and times of a regular meeting on a Wednesday, commencing at 7:00pm, and typically concluding at 9:00pm, might not suit everyone, however, is designed to:

- accommodate the majority where practical;
- allow for the greatest participation of both Elected Members and the public, including business owners and those that are employed in 'day jobs';
- have a regular time and date to in order to facilitate scheduling other activities and to maximise Elected Members and community participation; and
- not conflict and coordinate in as with local nearby governments, such that regional meetings can be more easily scheduled where required.

The Council is free to set the frequency of meetings, whichever day of the week it prefers and, indeed, the start time it prefers. It should, however, be cognoscente of staff costs associated with non-traditional work hours for support staff required, and set-up and preparation requirements.

Statutory Environment

Sections of the Acts, Regulations and/or Local Laws that apply to this item include:

- Local Government Act 1995, Local Government Act 1995, Sections 5.3 and 5.25 (1)(g); and
- Local Government (Administration) Regulations 1996, Regulation 12.

Regional local governments in WA generally meet on a monthly basis with the exception of January and cannot be more than 3 months apart.

A local government is required to give local public notice of any change to the date, time or place of scheduled Council Meetings pursuant to regulation, and the scheduled times, at least once per calendar year.

Policy Implications

There are no policy implications that relate.

Financial Implications

There are no financial implications, other than advertising expenses contained in the Council's Budget.

Strategic Implications

Shire of Narrogin Strategic Community Plan 2017-2027		
Objective	4.	Civic Leadership Objective (Continually enhance the Shire's organisational capacity to service the needs of a growing community)
Outcome:	4.1	An efficient and effective organisation
Strategy:	4.1.1	Continually improve operational efficiencies and provide effective services
Strategy:	4.1.2	Continue to enhance communication and transparency

Comment/Conclusion

It is proposed that Council, for the 2022 year, continue to hold its Ordinary Council meetings on the fourth Wednesday of the month commencing at 7:00 pm except for the month of January where no meeting is generally required or facilitated and December, where the meeting be held on the second Wednesday due to its proximity to Christmas.

It is also proposed that Council align the Briefing Session meetings and facilitate these meetings on the second Wednesday of the month at 6:00 pm except for the month of January where no meeting is planned.

Voting Requirements

Simple Majority

OFFICERS' RECOMMENDATION AND COUNCIL RESOLUTION 1021.012

Moved: Cr Broad

Seconded: Cr Pomykala

That with respect to the Ordinary Council Meeting Schedule for calendar year 2022, Council:

1. Endorse the following Ordinary Council meeting dates for the 2022 calendar year, being the fourth Wednesday of each month, commencing at 7:00 pm, other than January, where no meeting is held and December, where one meeting is held on the second Wednesday, due to the impact of Christmas.

January (Nil)	27 July
23 February	24 August
23 March	28 September
27 April	26 October
25 May	23 November
22 June	14 December

2. Advertise the schedule of Council Meeting dates in the Narrogin Observer, prior to the new calendar year, on the Shire of Narrogin website and on social media.
3. Request the Chief Executive Officer to convene these meetings, together with Confidential Council Monthly Briefing Sessions, on the second Wednesday evening commencing at 6:00 pm for those months, bar January and December.

CARRIED 9/0

11. ELECTED MEMBERS' MOTIONS OF WHICH PREVIOUS NOTICE HAS BEEN GIVEN

Nil

12. NEW BUSINESS OF AN URGENT NATURE APPROVED BY THE PERSON PRESIDING OR BY DECISION OF THE MEETING

Nil

13. CLOSURE OF MEETING

There being no further business to discuss, the Presiding Member declared the meeting closed at 9.24 pm and, pursuant to resolution 1020.012 of 27 October 2020, reminded Councillors of the next Ordinary Meeting of the Council, scheduled for 7.00 pm on Wednesday, 24 November 2021, at this same venue.



89 Earl Street, Narrogin
Correspondence to:
PO Box 1145, Narrogin WA 6312
T (08) 9890 0900
E enquiries@narrogin.wa.gov.au
W www.narrogin.wa.gov.au