



AGENDA

ORDINARY COUNCIL MEETING

22 SEPTEMBER 2020

NOTICE OF ORDINARY MEETING OF COUNCIL

Dear Elected Member & Community Members

Pursuant to resolution 1219.010 of the meeting held 18 December 2019, an Ordinary Meeting of the Shire of Narrogin will be held on Tuesday, 22 September 2020, in the Shire of Narrogin Council Chambers, 89 Earl Street, Narrogin, commencing at 7:00 pm.

A handwritten signature in black ink, appearing to read 'Dale Stewart'.

Dale Stewart
Chief Executive Officer

Acknowledgement of Noongar People

The Shire of Narrogin acknowledges the Noongar people as traditional custodians of this land and their continuing connection to land and community. We pay our respect to them, to their culture and to their Elders past and present.

Naatj ngiyen Birdiya Gnarojin kep unna nidja Noongar Moort ngaala maya nidja boodjera baarlap djoowak karlerl koolark. Ngalak niny ngullang karnan balang Bibolman baalap borong koora wer boorda.

Electronic copies of minutes and agendas are available for download from the Shire of Narrogin website www.narrogin.wa.gov.au

Alternative formats are also available upon request, including large print, electronic format (disk or emailed), audio or Braille



Shire of
Narrogin
Love the life

STRATEGIC COMMUNITY PLAN

SNAPSHOT

2017-27

VISION

A leading regional economic driver and a socially interactive and inclusive community.

MISSION

Provide leadership, direction and opportunities for the community.

KEY PRINCIPLES

In achieving the Vision and Mission, we will set achievable goals and work with the community to maintain a reputation of openness, honesty and accountability. In doing so we will:

- Respect the points of view of individuals and groups;
- Build on existing community involvement;
- Encourage community leadership;
- Promote self-reliance and initiative;
- Recognise and celebrate achievement;
- Support the principles of social justice; and
- Acknowledge the value of staff and volunteers.

OUR VALUES

Care with Trust & Teamwork

Caring - We display kindness and concern for one another and our community

Accountability - We accept responsibility for our actions and outcomes

Respect - We treat everyone how we would like to be treated

Excellence - We go the extra mile to deliver outstanding services

Trust - We share without fear of consequences

Team Work - We work together for a common goal

ECONOMIC

Support growth and progress, locally and regionally...

Growth in revenue opportunities

- Attract new industry, business, investment and encourage diversity whilst encouraging growth of local business
- Promote Narrogin and the Region
- Promote Narrogin's health and aged services including aged housing

Increased Tourism

- Promote, develop tourism and maintain local attractions

An effective well maintained transport network

- Maintain and improve road network in line with resource capacity
- Review and implement the Airport Master Plan

Agriculture opportunities maintained and developed

- Support development of agricultural services

Shire of Narrogin

SOCIAL

Provide community facilities and promote social interaction...

Provision of youth services

- Develop and implement a youth strategy

Build a healthier and safer community

- Support the provision of community security services and facilities
- Advocate for mental health and social support services
- Continue and improve provision of in-home care services

Existing strong community spirit and pride is fostered, promoted and encouraged

- Develop and activate Sport and Recreation Master Plan
- Engage and support community groups and volunteers
- Facilitate and support community events
- Provide improved community facilities (eg library/recreation)
- Encourage and support continued development of arts and culture

Cultural and heritage diversity is recognised

- Maintain and enhance heritage assets
- Support our Narrogin cultural and indigenous community

A broad range of quality education services and facilities servicing the region

- Advocate for increased education facilities for the region
- Advocate for and support increased education services

Agenda Ordinary Council Meeting 22/09/2020

ENVIRONMENT

Conserve, protect and enhance our natural and built environment...

A preserved natural environment

- Conserve, enhance, promote and rehabilitate the natural environment

Effective waste services

- Support the provision of waste services

Efficient use of resources

- Increase resource usage efficiency

A well maintained built environment

- Improve and maintain built environment

CIVIC

Continually enhance the Shire's organisational capacity to service the needs of a growing community...

An efficient and effective organisation

- Continually improve operational efficiencies and provide effective services
- Continue to enhance communication and transparency

An employer of choice

- Provide a positive, desirable workplace

Page | 3 FCEO027

DISCLAIMER

Council and Committee agendas, recommendations, minutes and resolutions are subject to confirmation by the Council or Committee and therefore, prior to relying on them, one should refer to the subsequent meeting of Council or the Committee with respect to their accuracy.

No responsibility whatsoever is implied or accepted by the Shire of Narrogin for any act, omission or statement or intimation occurring during Council/Committee meetings or during formal/informal conversations with staff.

The Shire of Narrogin disclaims any liability for any loss whatsoever and howsoever caused arising out of reliance by any person or legal entity on any such act, omission or statement or intimation occurring during Council/Committee meetings or discussions. Any person or legal entity who acts or fails to act in reliance upon any statement does so at that person's or legal entity's own risk.

In particular and without derogating in any way from the broad disclaimer above, in any discussion regarding any planning application or application for a license, any statement or limitation or approval made by a member or officer of the Shire of Narrogin during the course of any meeting is not intended to be and is not taken as notice of approval from the Shire of Narrogin. The Shire of Narrogin warns that anyone who has an application lodged with the Shire of Narrogin must obtain and should only rely on WRITTEN CONFIRMATION of the outcome of the application, and any conditions attaching to the decision made by the Shire of Narrogin in respect of the application.

Please note that meetings may be recorded for minute taking purposes.

CONTENTS

Agenda Item	Page
1. OFFICIAL OPENING/ANNOUNCEMENT OF VISITORS	6
2. RECORD OF ATTENDANCE/APOLOGIES/APPROVED LEAVE OF ABSENCE	6
3. DECLARATION OF INTEREST BY ELECTED MEMBERS AND COUNCIL EMPLOYEES IN MATTERS INCLUDED IN THE MEETING AGENDA	6
4. RESPONSE TO PREVIOUS PUBLIC QUESTIONS TAKEN ON NOTICE	7
5. PUBLIC QUESTION TIME	7
6. APPLICATIONS FOR LEAVE OF ABSENCE	7
7. CONFIRMATION OF MINUTES OF PREVIOUS MEETINGS	7
8. ANNOUNCEMENTS BY THE PERSON PRESIDING WITHOUT DISCUSSION	7
9. PETITIONS, DEPUTATIONS, PRESENTATIONS OR SUBMISSIONS	7
10. MATTERS WHICH REQUIRE DECISIONS	8
10.1 DEVELOPMENT AND REGULATORY SERVICES	8
10.1.1 PROPOSED PEDESTRIAN ACCESS WAY CLOSURE – CLOUGH PLACE/LOCK STREET, NARROGIN	8
10.1.2 POTENTIAL RELOCATION OF A FIRE TRUCK TO Highbury Townsite	13
10.2 TECHNICAL AND RURAL SERVICES	17
10.2.1 LANDCARE PROJECT FUNDING APPLICATIONS	17
10.2.2 FUTURE DEVELOPMENT OF ABLUTIONS AT LOT 103 SMITH STREET	51
10.3 CORPORATE AND COMMUNITY SERVICES	70
10.3.1 SCHEDULE OF ACCOUNTS PAID – AUGUST 2020	70
10.3.2 PROPOSED RATING POLICY – CONTIGUOUS LAND USE	72
10.3.3 REQUEST FOR CONTIGUOUS RATING OF LOT 3 DELLAR STREET AND LOTS 4, 922 & 923 MAY STREET, NARROGIN	82
10.4 OFFICE OF THE CHIEF EXECUTIVE OFFICER	95
10.4.1 COMMUNITY CHEST GRANT APPLICATIONS	95
11. ELECTED MEMBERS' MOTIONS OF WHICH PREVIOUS NOTICE HAS BEEN GIVEN	269
12. NEW BUSINESS OF AN URGENT NATURE APPROVED BY THE PERSON PRESIDING OR BY DECISION OF THE MEETING	270
13. CLOSURE OF MEETING	270

**ORDINARY COUNCIL MEETING
22 SEPTEMBER 2020**

1. OFFICIAL OPENING/ANNOUNCEMENT OF VISITORS

The Presiding Member, President Ballard, declared the meeting open at 7:00 pm.

2. RECORD OF ATTENDANCE/APOLOGIES/APPROVED LEAVE OF ABSENCE

Elected Members (Voting)

Mr L Ballard – Shire President (Presiding Member)
Cr T Wiese – Deputy Shire President
Cr M Fisher
Cr G Broad
Cr C Bartron
Cr J Early
Cr B Seale
Cr G Ballard

Staff

Mr D Stewart – Chief Executive Officer
Mr A Awang – Executive Manager Development & Regulatory Services
Mr T Evans – Executive Manager Technical & Rural Services
Mr F Ludovico – Executive Manager Corporate & Community Services
Ms C Thompson – Executive Assistant

Leave of Absence

Cr S Lushey

Apologies

Absent

Visitors

3. DECLARATION OF INTEREST BY ELECTED MEMBERS AND COUNCIL EMPLOYEES IN MATTERS INCLUDED IN THE MEETING AGENDA

Name	Item No	Interest	Nature

4. RESPONSE TO PREVIOUS PUBLIC QUESTIONS TAKEN ON NOTICE

Nil

5. PUBLIC QUESTION TIME

6. APPLICATIONS FOR LEAVE OF ABSENCE

The next meeting is scheduled for 27 October 2020.

7. CONFIRMATION OF MINUTES OF PREVIOUS MEETINGS

7.1 Ordinary Council Meeting

OFFICERS' RECOMMENDATION

That the minutes of the Ordinary Council Meeting held on 25 August 2020 be confirmed as an accurate record of the proceedings.

8. ANNOUNCEMENTS BY THE PERSON PRESIDING WITHOUT DISCUSSION

9. PETITIONS, DEPUTATIONS, PRESENTATIONS OR SUBMISSIONS

Nil

10. MATTERS WHICH REQUIRE DECISIONS

10.1 DEVELOPMENT AND REGULATORY SERVICES

10.1.1 PROPOSED PEDESTRIAN ACCESS WAY CLOSURE – CLOUGH PLACE/LOCK STREET, NARROGIN

File Reference	28.7.2
Disclosure of Interest	Neither the Author nor Authorising Officer have any Impartiality, Financial or Proximity Interests that requires disclosure.
Applicant	Shire of Narrogin
Previous Item Numbers	Nil
Date	10 September 2020
Author	David Johnston – Planning Officer
Authorising Officer	Azhar Awang – Executive Manager Development and Regulatory Services
Attachments	1. Locality Plan 2. Advertising Plan

Summary

Council is requested to advertise the proposed closure of the Pedestrian Access Way (PAW) between Clough Place and Lock Street, in order to formalise the closure of the existing PAW that has been in place since 2003 as indicated by Landgate's aerial photograph.

The PAW is bordered by Lots 57 and 56 (No. 6 and 8) Clough Place, Narrogin and Lots 35 and 36 (No. 72 and 70) Lock Street, Narrogin.

Background

The Administration recently became aware of an unauthorised use and effective closure of the PAW between Clough Place and Lock Street. The PAW has been fenced at each end and divided into two sections, one connecting to Lot 35 (No. 72) Lock Street and the other to Lot 56 (No. 8) Clough Place.

The section of PAW connected to Lot 56 (No. 8) Clough Place contains an unauthorised carport structure. The owner of the property has indicated if the PAW closure goes ahead, they would like to keep the carport in place. The Shire will be seeking a retrospective application upon closure of the PAW.

Comment

Council is requested to advertise the proposed closure of the PAW between Clough Place and Lock Street, Narrogin in accordance with the Land Administration Act 1997 Section 52. The subject PAW is approximately 60 metres long and 3 metres wide with a total area of approximately 176 m².

Services

There is a street light at the northern boundary of the PAW. The closure will require the approval from the relevant service authorities as part of the formal advertising process. There are no other visible services in the PAW, however this will be ascertained during the formal advertising process through the relevant service authorities.

Pedestrian Movements

The closure will have no impact on pedestrian movements as the PAW has been closed for a number of years and does not provide the desired pedestrian connectivity to other community facilities within the surrounding area.

Consultation

Consultation has been undertaken with the owner of the lot with the carport who has advised that the laneway was closed by the Shire in approximately 2002/2003. The Administration has been unable to verify this statement from the Shire's records.

If the Officers' recommendation is supported, letters inviting comment will be sent to:

- Land owners adjoining the subject PAW;
- Department of Planning Lands and Heritage;
- Western Power;
- Water Corporation; and
- Telstra.

The proposal will also be advertised in the Narrogin Observer for a period of 30 days in accordance with section 52 of the Land Administration Act 1997.

On this occasion given the PAW has been effectively closed for many years, the Administration's view is that a sign advising of the proposed closure erected at either end of the PAW is not required.

Statutory Environment

The following legislation is relevant to the proposal:

Land Administration Act 1997 Section 52 – local government may request the Minister for Lands to acquire a laneway subject to compliance with the requirements of the Land Administration Regulations 1998 in regulation 6.

Policy Implications

Nil

Financial Implications

There are costs associated with the laneway closure such as advertising, administration, and land valuation that may not be recovered. These costs are predominantly administrative in nature and relatively minor. As the sale of the land is between the Crown (ie Department of Planning Lands and Heritage) and the land owners, proceeds of the land sale do not come to the Shire of Narrogin.

Strategic Implications

Shire of Narrogin Strategic Community Plan 2017-2027		
Objective	3.	Environment Objective (Conserve, protect and enhance our natural and built environment)
Outcome:	3.4	A well maintained built environment
Strategy:	3.4.1	Improve and maintain built environment

Voting Requirements

Simple Majority

OFFICERS' RECOMMENDATION

That with respect to the proposed PAW closure between Lots 57 and 56 (No. 6 and 8) Clough Place, Narrogin and Lots 35 and 36 (No. 72 and 70) Lock Street, Narrogin, Council resolve the following:

1. Prior to proceeding with the formal closure of the PAW, the CEO is to obtain written agreement from the participating adjoining land owners to bear all costs associated with the closure of the PAW, including, land valuation, surveying and transfer of land.
2. Subject to condition 1 above:
 - a. Pursuant to the requirements of the Transfer of Land Act and Land Administration Act, the Shire of Narrogin advertise its intent to close the PAW between Lots 57 and 56 (No. 6 and 8) Clough Place, Narrogin and Lots 35 and 36 (No. 72 and 70) Lock Street, Narrogin;
 - b. Invite submissions from relevant service authorities;
 - c. Request a land valuation from Landgate (Valuer General); and
 - d. Upon the closing date of submissions, the matter be reported to Council including all submissions received during the submission period for Council's further consideration.

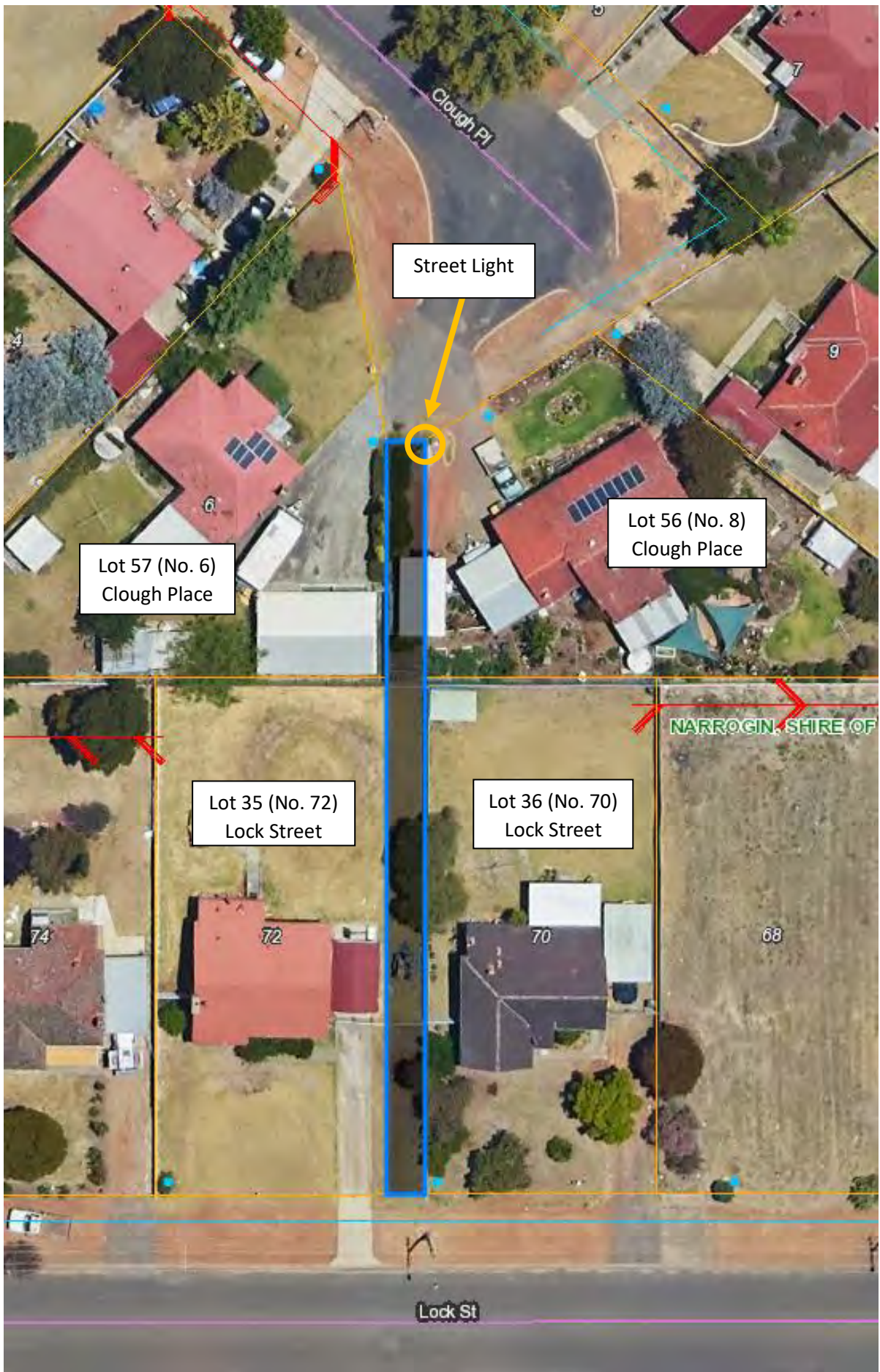

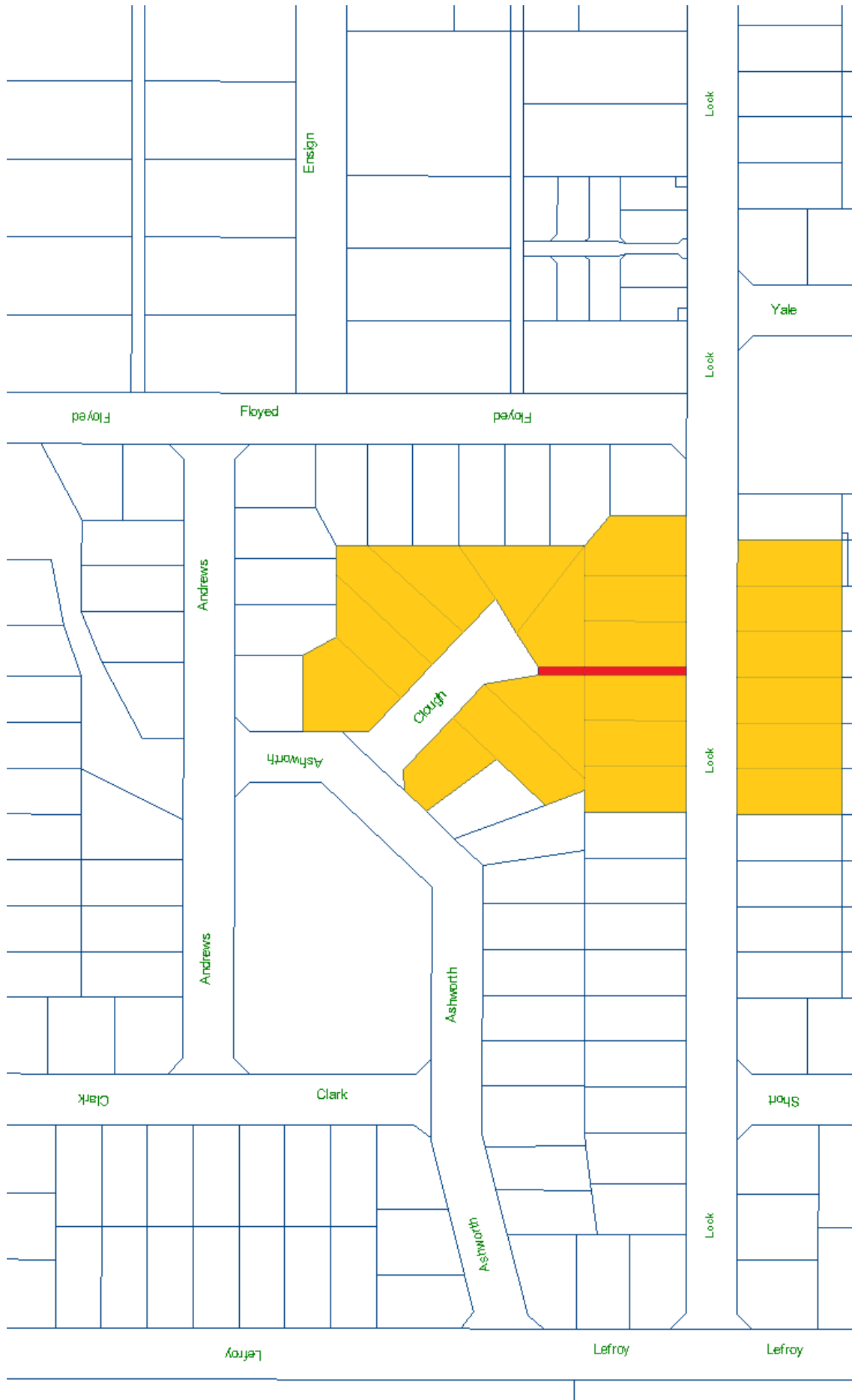

10.1.2 POTENTIAL RELOCATION OF A FIRE TRUCK TO HIGHBURY TOWNSITE

File Reference	9.8.5
Disclosure of Interest	Neither the Author nor Authorising Officer have any Impartiality, Financial or Proximity Interests that requires disclosure.
Applicant	Shire of Narrogin
Previous Item Numbers	Nil
Date	7 September 2020
Author	Azhar Awang – Executive Manager Development and Regulatory Services
Authorising Officer	Dale Stewart – Chief Executive Officer
Attachments	

Summary

Council's consideration is requested in regards to the potential relocation of one of the 3.4 Fire Trucks to Highbury Townsite.



Background

On 22 January 2020, the Shire's Chief Executive Officer (CEO) wrote to all the Fire Control Officers in the Shire for feedback on the relocation of one of the 3.4 Fire Trucks, which is owned and managed by the Shire, and is currently operated by the Narrogin Central Volunteer Bush Fire Brigade.

The Shire currently has two (2) 3.4 Fire Trucks which are located in the Narrogin townsite, adjacent to the Town Brigade's Fire and Rescue Services. The proposal is to locate one of the 3.4 single cab Isuzu fire trucks to the Highbury Townsite so that it can service areas to the south, east and west of the Shire

in the event of a bushfire. The proposal is also to construct a purpose-built shed adjacent to the Highbury townsite toilets on the Great Southern Highway.

The Shire received six (6) responses, two (2) in favour and four (4) against the proposal.

On 17 June 2020, the submissions received were tabled at the Bush Fire Advisory Committee. The issues and concerns raised during the submission period were in the number and ability of existing volunteers in Highbury to adequately operate the Fire Truck and respond to a fire event when required.

Comment

Bushfire Brigades

The Shire has ten (10) Brigades, which are operated by the Shire's Bush Fire Brigade volunteers.

The 3.4 Fire Trucks are Bush Fire vehicles and not for structure firefighting purposes and therefore will not be able to attend to or fight any structure fires in the Highbury townsite. This activity can only be performed by the Town's Fire and Rescue Brigades and Red Trucks who are trained for such purposes.

Submissions

The concerns expressed by some of the Brigades regarding the relocation of one of the Fire Trucks to Highbury Townsite can be summarised as follows:

- The idea of locating the Fire Truck is sound, but the practicality will make it difficult to achieve successfully.
- The responsibility for manning the truck will fall on too few people as there wouldn't be many people in close proximity to Highbury allowing for quick deployment.
- Brigades such as Nomans Lake are too far away to be of any help.
- Considering there is a reasonable investment required by ratepayers for the shed it would have to be guaranteed to work.
- One possibility going forward would be to provide training in the operation of these trucks to people outside of Narrogin allowing them to be able to get a truck if required especially if there aren't enough numbers in town.
- The relocation of one of the 3.4 Fire Trucks from its present location of Narrogin to Highbury not in the best interest of the operation of firefighting and would prefer an additional unit to be bought and located at Highbury.
- The location of a bush fire truck in Highbury would not be able to be used for structural fires, where Narrogin Fire and Rescue man and operate both of the 3.4 and are fully qualified and trained for both structural and bush fires.
- The Highbury District should have a bush fire truck and all efforts to get one should be pursued. There has been significant efforts to obtain a fire truck over the past years but unfortunately this has not been successful.
- Currently the operation with two trucks based in Narrogin is working quite successfully where they handle both types of fires within the Narrogin town site, the Shire and surrounding districts where necessary.
- Having staff to maintain Fire Trucks, response time to other areas will be slower.
- Should be trying to get another Fire Truck for Highbury not relocate.
- While we give this proposal 'in principle' support, bearing in mind the future location of a possibly volatile business in close proximity to the Highbury townsite, we would much prefer to see an additional truck bought and located there, rather than a relocated one.

- While we appreciate that the Highbury community have discussed this matter and feel confident that they can commit to housing, maintaining and manning a truck situated in their townsite, we do have some grave concerns about it. It is a big commitment having people with the necessary skills and experience available to man the truck when required. This would necessitate having their employers on board to enable the volunteers to leave at a moment's notice when needed.
- The truck would need to be available to attend most fires in the Narrogin Shire and beyond, not just locally. Although we have great confidence in the local brigades' ability to man the unit, we are concerned that this would lessen the overall number of farm units in attendance, as the volunteers manning the shire fire truck would no longer be able to take their own units to the fire. Experience shows that we need them both.
- We believe that our Shire has become severely undermanned with units due to its current demographics. As larger properties have expanded at the expense of smaller farms, we now have fewer small farms and personnel located in our district.
- There are also numerous hobby farms which are often not inhabited permanently or not able to supply and man a fire unit.
- It would therefore be our preference to keep the current status quo with all trucks being based in Narrogin. We would encourage the shire to continue to lobby for further trucks for our Shire, with the possibility of one being housed in Highbury in the future.

Currently the existing Fire Trucks are being well maintained and operated by the Central Brigades and regularly attend Bush Fire emergency call outs.

As there are not enough personnel to adequately maintain and operate the Fire Truck, if it was to be located in the Highbury townsite, it is recommended that the Fire Truck be kept at its existing location.

Furthermore, according to the Brigades, it takes approximately the same time, from the time of receiving the emergency call and for volunteers to respond and attend the fire and therefore will not improve the overall response time if the Fire Truck is to be located in Highbury townsite.

The Brigades have indicated that most of the volunteers are not trained to drive and operate the fire trucks. At the BFAC meeting it was recommended that the Administration staff liaise with DFES to ensure that FCO's and other interested Brigade members are trained to operate the Shire's Fire Trucks at the commencement of each fire season.

Consultation

Letters were sent by the Chief Executive Officer to all Fire Control Officers seeking comments and the Chief Executive Officer presented the submissions to the Bush Fire Brigade Committee meeting on 17 June 2020 for consideration. At that meeting the outcome was that it was noted that Administration staff were to liaise with DFES staff to ensure that all FCO's are offered training on the Shire's Fire Trucks at the commencement of each fire season.

Statutory Environment

Nil

Policy Implications

Nil

Financial Implications

The Shire previously allocated \$30,000 in the 2019/2020 for the supply and construction of a shed to house the Fire Truck. This has not progressed and no funds have been allocated in this year's Budget for the Fire Shed due to the above process and discussions.

Strategic Implications

Shire of Narrogin Strategic Community Plan 2017-2027		
Objective	2.	Social Objective (To provide community facilities and promote social interaction)
Outcome:	2.2	Build a healthier and safer community
Strategy:	2.2.1	Support the provision of community security services and facilities
Outcome:	2.3	Existing strong community spirit and pride is fostered, promoted and encouraged
Strategy:	2.3.2	Engage and support community groups and volunteers

Voting Requirements

Simple Majority

OFFICERS' RECOMMENDATION

That, with respect to the potential relocation of a Fire Truck to the Highbury townsite, Council:

1. Not support the relocation of either of the Shire's 3.4 Bushfire Trucks;
2. Request that the Chief Executive Officer liaise with DFES to ensure that all Fire Control Officers and other interested Brigade members have the opportunity to be trained to operate the Shire's Bushfire Trucks at the commencement of each fire season; and
3. Write to all the Fire Control Officers on the above outcome.

10.2 TECHNICAL AND RURAL SERVICES

10.2.1 LANDCARE PROJECT FUNDING APPLICATIONS

File Reference	15.1.2
Disclosure of Interest	Neither the Author nor Authorising Officer have any Impartiality, Financial or Proximity Interests that requires disclosure.
Applicant	Shire of Narrogin
Previous Item Numbers	Nil
Date	15 September 2020
Author	Loriann Bell – Administrative Support Officer
Authorising Officer	Dale Stewart – Chief Executive Office
Attachments	<ol style="list-style-type: none">1. Landcare Project Funding Applications2. Landcare Project Funding Guidelines

Summary

Applications were invited from residents within the Shire of Narrogin, to apply for Shire Landcare Project Funding for the purpose of purchasing native vegetation to rehabilitate degraded land within the Shire. The Guidelines require applicants to match the grant dollar for dollar.

Two applications from rural Shire residents have been received by the Administration for Landcare Project Funding. The Administration requests the Council to support the recommendation by the Community Chest Grants Reference Group, and approve the request for funding.

Background

At the Ordinary Council Meeting held 25 February 2020, with respect for the Landcare Reserve Fund application process, Council resolved to:

“Approve the process to be modelled on the current Shire of Narrogin Community Chest Grant funding process.

Authorise the Chief Executive Officer to formulate and implement a Landcare Project funding process including guidelines, selection criteria and all templates required and be made available on the Shire’s website in keeping with the concepts included in this report for the approval of the Reference Group; and

Amend the Terms of Reference for the Community Chest Reference Group to include assessment of Landcare applications for recommendation to Council”.

Subsequently the above resolution was carried out.

Advertising for Round 1 Landcare Project Funding was advertised via the Shire’s website, Shire’s Facebook and in the local paper – Narrogin Observer.

Round one applications were invited from 15 July 2020 and closed 31 August 2020.

Comment

The Administration received two applications for Landcare Project Funding. Applications were as follows:

- 1) Mr A Borthwick – 1733 Yilliminning Rd Boundain, 6312. Property name: ‘Cranstoun’.

Mr Borthwick’s application requested Landcare Project funding for the amount of \$3,547.90.

Mr Borthwick’s property covers a total area of 1,400 hectares with 10 acres that will undergo rehabilitation through native tree planting.

Several types of native plants have been purchased to rehabilitate the land effected by salinity that is evident on the parts of the property. A total amount of 5,497 native plants have been purchased for the project due to be completed in November 2020. The applicant is seeking reimbursement for the native plants purchased.

The total project cost is estimated to be \$6,697.90. The applicant has indicated they will contribute \$3,150 in in-kind and donated labour and materials.

- 2) Mr K Quartermaine – 875 Yilliminning Rd, Narrogin Valley, 6312.

Mr Quartermaine’s application requested Landcare Project funding for the amount of \$5,000.

Approximately 6 hectares of property have undergone planting with native plants with another 7.76 hectares of creek line due to be planted in 2020 (see Attachment 2).

Over 7,000 native seedlings will be planted to rehabilitate salt effected land along the Blackwood catchment on his property, which will prevent further erosion and salinity of productive land. The applicant is seeking reimbursement for the native plants purchased.

The total project cost is estimated at \$13,728, the applicant has indicated their cash contribution of \$8,728.

The assessment criteria for Landcare Funding applications states that retrospective funding will not be supported. Both applicants have identified that they have already purchased native plants for their Landcare rehabilitation projects in July and August 2020.

It is the Administration’s opinion that the Council support both applications on this occasion, as the inaugural invitation period was during optimal winter planting conditions i.e. July/August. Considering the application submission timeline and subsequent Reference Group meeting and referral to Council, and if approved, these two applicants would be restricted with the purchase and planting identified in the applications in the current planting season.

Supporting documentation is provided by both applicants in Attachment 1.

The members of the Reference Group discussed the dates for advertising this funding opportunity, and noted that due to the timing of planning, budgeting and planting, they agreed that the Guidelines be amended to reflect one round of grants to be advertised in February. Details are in Recommendation 2 of 2.

Consultation

Consultation has been undertaken with the:

- Community Chest Grants Reference Group
- Chief Executive Officer
- Executive Manager Technical and Rural Services
- Mr Andrew Borthwick – Applicant
- Mr Kieran Quartermaine – Applicant

The grants were advertised in July and August 2020 closing on 31 August in the Narrogin Observer, the Shire's Facebook page and via direct communication to community and sporting groups.

Statutory Environment

Nil

Policy Implications

Council Policy 1.14 Community Engagement Policy relates and has been considered.

Financial Implications

The 2020/21 Budget has an allocation of \$25,000 for Environmental Landcare Community Projects. If Council approve both applications with a total combined value of \$8,547.90 then there would be a balance of \$18,420.15 for Round 2 of the Landcare Project Funding grants.

Strategic Implications

Shire of Narrogin Strategic Community Plan 2017-2027		
Objective	3.	Environment Objective (Conserve, protect and enhance our natural and built environment)
Outcome:	3.1	A preserved natural environment
Strategy:	3.1.1	Conserve, enhance, promote and rehabilitate the natural environment

Voting Requirements

Simple Majority

OFFICERS' AND REFERENCE GROUP RECOMMENDATION 1 OF 2

That, with respect to the Landcare Project Fund Round 1, the Community Chest Reference Group recommend that Council approve the applications subject to the listed conditions:

1. Mr Borthwick \$1,773.95 being 50% of the cost of \$3,547.90 to purchase native vegetation; and
2. Mr Quartermaine \$4,806 being 50% of the cost of \$9,612 to purchase native vegetation.

Conditions:

- a) The Applicants will provide the administration with copies of paid invoices for native vegetation related to the project, and submit a tax invoice (plus GST if applicable) for the amount of the approved grant; and
- b) The Applicants are to acquit the grant by 31 December 2020 and present copies of paid invoices and receipts related to the purchase of native vegetation and submit to the Administration together with photographs of the completed project
- c) Upon satisfying condition (a) and (b) the Shire will reimburse to the applicant the amount of the approved granted funds.

OFFICERS' AND REFERENCE GROUP RECOMMENDATION 2 OF 2

That, with respect to the Landcare Project Fund Guidelines, the members of the Community Chest Reference Group recommend to Council that the Guidelines be amended to reflect one round of grants per year, to be advertised in February.

11.6.4 IEM 2021216

LANDCARE PROJECT FUND APPLICATION FORM (FTRS004)



Shire of
Narrogin
Love the life

89 Earl Street
PO Box 1145
Narrogin WA 6312

(08) 9890 0900

www.narrogin.wa.gov.au
enquiries@narrogin.wa.gov.au

CASHIER HOURS:
8:30am – 4:30pm
MONDAY- FRIDAY

The Shire of Narrogin provides funding assistance through the Landcare Project Fund, to rural applicants within the Shire of Narrogin for the purchase of native vegetation for planting on their property. Funding is available up to a maximum of \$5,000.

Applications should be submitted to the Shire by the closing date. Grants must be acquitted within the financial year of approval.

1. APPLICANT DETAILS

Name of Applicant

AG & MF BORTHWICK / ANDREW BORTHWICK

Property Address

[Redacted]

Phone

[Redacted]

Mobile

[Redacted]

Email

[Redacted]

Do you have an ABN?

Yes No

ABN

14 415 967 455

Are you registered for GST?

Yes No

2. PREVIOUS LANDCARE PROJECT FUNDING.

Have you received Landcare Project funding previously?

Yes	<input checked="" type="radio"/> No
-----	-------------------------------------

If yes, please tell us what year, a brief description of the project and the amount of Landcare Project funds received.

3. PROJECT DETAILS

Please provide the dollar amount being requested. (max \$5,000)

\$3547.90 EX GST

On what lot(s) or location(s) numbers are the trees being planted? (please specify Lot/Location/Street number)

WILLIAMS LOCATION 4830

Are you the owner of the property?

<input checked="" type="radio"/> Yes	<input type="radio"/> No
--------------------------------------	--------------------------

If No, who is the owner?

--

Do you have the owner's permission to undertake this project?

<input checked="" type="radio"/> Yes	<input type="radio"/> No
--------------------------------------	--------------------------

Please provide a brief description of your project for which you are applying for funds. (maximum of 100 words)

'CRANSTOWN' (PROPERTY NAME) HAS A LOW LYING AREA PRONE TO FLOODING AND SALT SCALDS. FOR OVER 40 YEARS OF REVENGING, WATER CONTROL AND PLANTING TREES AND SHRUBS HAS STARTED TO OVERCOME THE DEGRADATION OF THESE AREAS. THIS IS AN ONGOING PROJECT.

How will your project benefit the land and environment?

PAST EXPERIENCE INDICATE WITH CAREFUL SELECTION OF PLANT SPECIES THAT WILL THRIVE IN THESE AREAS, WILL PROVIDE GROUND COVER, REDUCE WATER TABLE LEVELS AND ENCOURAGE OTHER SPECIES OF VEGETATION TO THRIVE IN THIS ENVIRONMENT

Estimated project start date.

JULY 2020

Estimated project completion date.

NOVEMBER 2020

4. PROJECT BUDGET

Please use the sample budget below as a guide to calculate income and expenditure in the Detailed Project Budget on Page 4. Applicant/in-kind labour is to be calculated at \$25 per hour.

Example Budget

INCOME		EXPENDITURE <i>(please attach copies of quotes for cash expenditure)</i>	
Amount of approved Landcare Project Funds	\$2,500	Materials: Purchase of Australian Native vegetation (ie trees and shrubs)	\$7,000
Applicant's cash contribution	\$4,500	Applicants in-kind expenditure labour 300 hours @ \$25 p/h \$7,500 fencing 50m @ \$10 p/m \$500	\$8,000
Applicants in-kind contribution <i>(please list items .i.e .labour/ materials/equipment/machinery/wages)</i>	\$7,500		
Other grants or cash donations	Nil		
Donations - materials <i>(please list items .i.e fencing/irrigation/plants)</i>	\$500		
Total *Income	\$15,000	Total *Expenditure	\$15,000

*Income and *Expenditure amounts must be equal

Detailed Project Budget

INCOME		EXPENDITURE (please attach copies of quotes for cash expenditure)	
Amount of approved Landcare Project Funds	\$ 3547.90	Materials: Purchase of Australian Native vegetation (ie trees and shrubs)	\$ 3547.90
Applicant's cash contribution	\$	Applicants in-kind expenditure	\$
		LABOUR 2 x 25 HRS x \$25/HR	1250.00
		TREE PLANTER	400.00
		TRACTOR	500.00
Applicants in-kind contribution (please list items .i.e .labour/ materials/equipment/machinery/wages)	\$ 2150.00		
Other grants or cash donations	\$		
Donations - materials (please list items .i.e fencing/irrigation/plants)	\$ 1000.00	FENCING	1000.00
Total *Income	\$ 6697.90	Total *Expenditure	\$ 6697.90

*Total Income and Expenditure should be equal

* ALL INCOME = EXPENDITURE EX GST

Declaration by applicant

I declare that I am authorised to submit this application and that the information presented is correct to the best of my knowledge.

Print Name

ANDREW BORTHWICK

Signature



Date

13.8.2020

The Trustee for the Parnell Family Trust

ABN: 11 720 757 331

PO Box 24

Tincurrin 6361

Phone: 08 9883 2024

Email: nursery@parnellsnursery.com.au

Supplied To: Borthwick AG & MF
1733 Yilliminning Rd
Boundain

Invoice Date: 30/07/2020
Invoice #: 12381
Page : 1 / 1
Due Date: 06 Aug 2020

ABN: 14 415 967 455

TAX INVOICE

Description	Unit Price \$	Quantity	Ex.GST	GST	Total (inc GST)
Seedling Invoice Saltbush and Broombush 2020	0.50	5483	2,741.50	274.15	3,015.65 Dr
			2,741.50	274.15	
			Total (inc GST):		\$3,015.65 Dr

PAID

11.8.2020

Please tear off this section And return with payment to:-

For Direct Debit

CTB Narrogin
BSB 066522
Acc 10039919

The Trustee for the Parnell Family Trust
PO Box 24
Tincurrin 6361

Invoice Date: 30/07/2020
Invoice Number: 12381
Invoice Total: \$3,015.65 Dr
Due Date: 06 Aug 2020
Supplied To: Borthwick AG & MF



Andrew Borthwick
 Attention: AG & MF Borthwick
 [REDACTED]
 NARROGIN WA 6312

Invoice Date
 05 Aug 2020
 Invoice Number
 N20355
 Reference

Due Date:
 12 Aug 2020

TAX INVOICE

LISA 0429 371 076
 DUSTIN 0427 371 075

Quantity	Description	Unit Price (ex)	GST	Amount (ex)
14.00	Anameka Fodder Shrub (72x)	57.60	80.64	806.40
1.00	Delivery of Seedlings will be invoiced separately	0.00	0.00	0.00
2.00	Ripper Tips for Tree Planter	150.00	30.00	300.00
Subtotal				1,106.40
Total GST 10%				110.64
Invoice Total				1,217.04
Amount Paid				0.00
BALANCE				1,217.04

Due Date: 12 Aug 2020
 Bank Details: McCreery Business Trust
BSB: 036 177 Account: 155 950
 Reference: Borthwick

A \$10 late payment fee will be applied
 each fortnight after due date

PAID

11.8.2020



Search "Chatfields"
 on Facebook

McCreery Business Trust t/as Chatfield's Tree Nursery & Chatfield Engineering
 PO Box 1 Tammin WA 6409
 Dustin 0427371075 Lisa 0429371076 info@chatfields.com.au www.chatfields.com.au
NBN 62 263 249 273



LANDCARE PROJECT FUNDING GUIDELINES (FTRS003)



89 Earl Street
PO Box 1145
Narrogin WA 6312

(08) 9890 0900

www.narrogin.wa.gov.au
enquiries@narrogin.wa.gov.au

CASHIER HOURS:
8:30am – 4:30pm
MONDAY- FRIDAY

The Shire of Narrogin provides funding assistance through the Landcare Project Fund, to rural applicants within the Shire of Narrogin, for the purchase of native plants planting on their property. Funding is available up to a maximum of \$5,000.

Round 1 opens 15 July closes 31 August
Round 2 opens 1 February closes 28 February

What will be funded

- Purchase costs of Australian native plants i.e. trees and shrubs.

What will not be funded

- Deficit funding or retrospective funding.
- Recurrent expenditure (i.e. salaries and operational costs).
- Proposals where alternative sources of funding are available.
- Maintenance, repairs or upgrades to machinery, equipment, fencing or other property infrastructure or assets.
- Maintenance, repairs or upgrades to buildings or property which are the property of the State Government.

Eligibility

- Organisations and individuals are eligible to apply for funding.
- No individual application shall receive in excess of \$5,000 project funding.
- The project must demonstrate the benefit, improvement and outcomes that will be achieved for land rehabilitation or regeneration.
- Projects are required to be completed and acquitted within the financial year of the funding approval.
- Organisations or individuals who have failed to acquit previously received Landcare Project funding within the required timeframe may be ineligible to apply.
- Applications should be submitted using the Application Form, with copies of quotes attached.
- Applications should be addressed to the above and received by the closing date.

Assessment criteria

- Demonstrated capacity to manage and be accountable for the funds and the project.
- Demonstrated cash contribution to the proposed project.
- Funding will be available for the supply of native vegetation ie trees or shrubs to improve salt effected, eroded and other land areas in need of rehabilitation.
- Funding is not available for fencing, however projects demonstrating that the applicant will be supplying and erecting fencing for new vegetation will be viewed favourably.
- Funding will only be available for land outside Narrogin and Highbury town sites, and within the Shire of Narrogin, with no minimum lot size.
- Copies of quotes for materials and services to deliver the project must be provided;
- Provision of a detailed cash project budget showing expenditure and income including project amount requested.
- Demonstrate the extent of and the contribution in cash or in-kind by the applicant.
- Projects that commit to matching dollar for dollar support will be viewed favourably.
- Applications that can demonstrate that materials will be purchased using local businesses will be viewed favourably.
- Compliance with all acquittal requirements for any previous Shire funding received.
- Compliance with appropriate Local Laws, Policies, Acts, Regulations and Standards.

Applicants are encouraged to contact the Shire's Technical Support Officer (Technical and Rural Services) by email to enquiries@narrogin.wa.gov.au or by telephoning 9890 0900 to discuss their project, or to obtain a copy of the Application Form. Alternately an Application Form can be downloaded [here](#).

LANDCARE PROJECT FUND APPLICATION FORM (FTRS004)



89 Earl Street
PO Box 1145
Narrogin WA 6312

(08) 9890 0900

www.narrogin.wa.gov.au
enquiries@narrogin.wa.gov.au

CASHIER HOURS:
8:30am – 4:30pm
MONDAY- FRIDAY

The Shire of Narrogin provides funding assistance through the Landcare Project Fund, to rural applicants within the Shire of Narrogin for the purchase of native vegetation for planting on their property. Funding is available up to a maximum of \$5,000.

Applications should be submitted to the Shire by the closing date. Grants must be acquitted within the financial year of approval. A copy of the Acquittal Form can be downloaded [here](#).

1. APPLICANT DETAILS

Name of Applicant

Keiran Quartermaine

Property Address

[REDACTED]

Phone

[REDACTED]

Mobile

[REDACTED]

Email

[REDACTED]

Do you have an ABN?

Yes No

ABN

533 41 552 293

Are you registered for GST?

Yes No

2. PREVIOUS LANDCARE PROJECT FUNDING.

Have you received Landcare Project funding previously?

Yes No

If yes, please tell us what year, a brief description of the project and the amount of Landcare Project funds received.

3. PROJECT DETAILS

Please provide the dollar amount being requested. (max \$5,000)

\$5000

On what lot(s) or location(s) numbers are the trees being planted? (please specify Lot/Location/Street number)

Williams loc 4285 @ 875 YILLIMINNING ROAD
NARROGIN VALLEY 6312. (BOUNDAIN)

Are you the owner of the property?

Yes No

If No, who is the owner?

Do you have the owner's permission to undertake this project?

Yes No

Please provide a brief description of your project for which you are applying for funds. (maximum of 100 words)

An ongoing regeneration program of saltland at the beginning of the blackwood catchment. Already completed 6ha @ 875 YILLIMINNING ROAD NARROGIN VALLEY (photo attached). 2020 we are planting 7.76 ha of creekline which we have recently fenced off. (photo attached).

How will your project benefit the land and environment?

covering the banks & creekline (now salty) will eliminate severe erosion & further salty-waterlogging of existing productive land.

(photo attached)

Estimated project start date.

28/7/2020

Estimated project completion date.

9/8/2020

4. PROJECT BUDGET

Please use the sample budget below as a guide to calculate income and expenditure in the Detailed Project Budget on Page 4. Applicant/in-kind labour is to be calculated at \$25 per hour.

Example Budget

INCOME		EXPENDITURE <i>(please attach copies of quotes for cash expenditure)</i>	
Amount of approved Landcare Project Funds	\$2,500	Materials: Purchase of Australian Native vegetation (ie trees and shrubs)	\$7,000
Applicant's cash contribution	\$4,500	Applicants in-kind expenditure labour 300 hours @ \$25 p/h \$7,500 fencing 50m @ \$10 p/m \$500	\$8,000
Applicants in-kind contribution <i>(please list items .i.e .labour/ materials/equipment/machinery/wages)</i>	\$7,500		
Other grants or cash donations	Nil		
Donations - materials <i>(please list items .i.e fencing/irrigation/plants)</i>	\$500		
Total *Income	\$15,000	Total *Expenditure	\$15,000

*Income and *Expenditure amounts must be equal

Detailed Project Budget

INCOME		EXPENDITURE (please attach copies of quotes for cash expenditure)	
Amount of requested Landcare Project Funds	\$ 5000	Materials: Purchase of Australian Native vegetation (ie trees and shrubs)	\$ 9612
Applicant's cash contribution	\$	Applicants in-kind expenditure	\$
		Contract labour (attached bill)	535
		Fencing 1.58 km @ \$2.50	2645
		2x WORKMAN WAGES @ 18hrs @ \$26	936
Applicants in-kind contribution (please list items .i.e .labour/ materials/equipment/machinery/wages)	\$ Nil		-
Other grants or cash donations	\$ Nil		-
Donations - materials (please list items .i.e fencing/irrigation/plants)	\$ Nil		-
Total *Income	\$ Nil	Total *Expenditure	\$ 13728

*Total Income and Expenditure should be equal

Declaration by applicant

I declare that I am authorised to submit this application and that the information presented is correct to the best of my knowledge.

Print Name

KEIRAN QUARTERMAINE

Signature

Date

5/8/2020.



CARANOO

Carlton Springs - KJ & RE Quartermaine

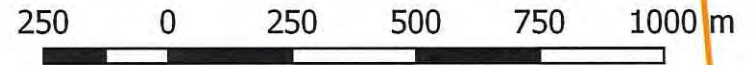
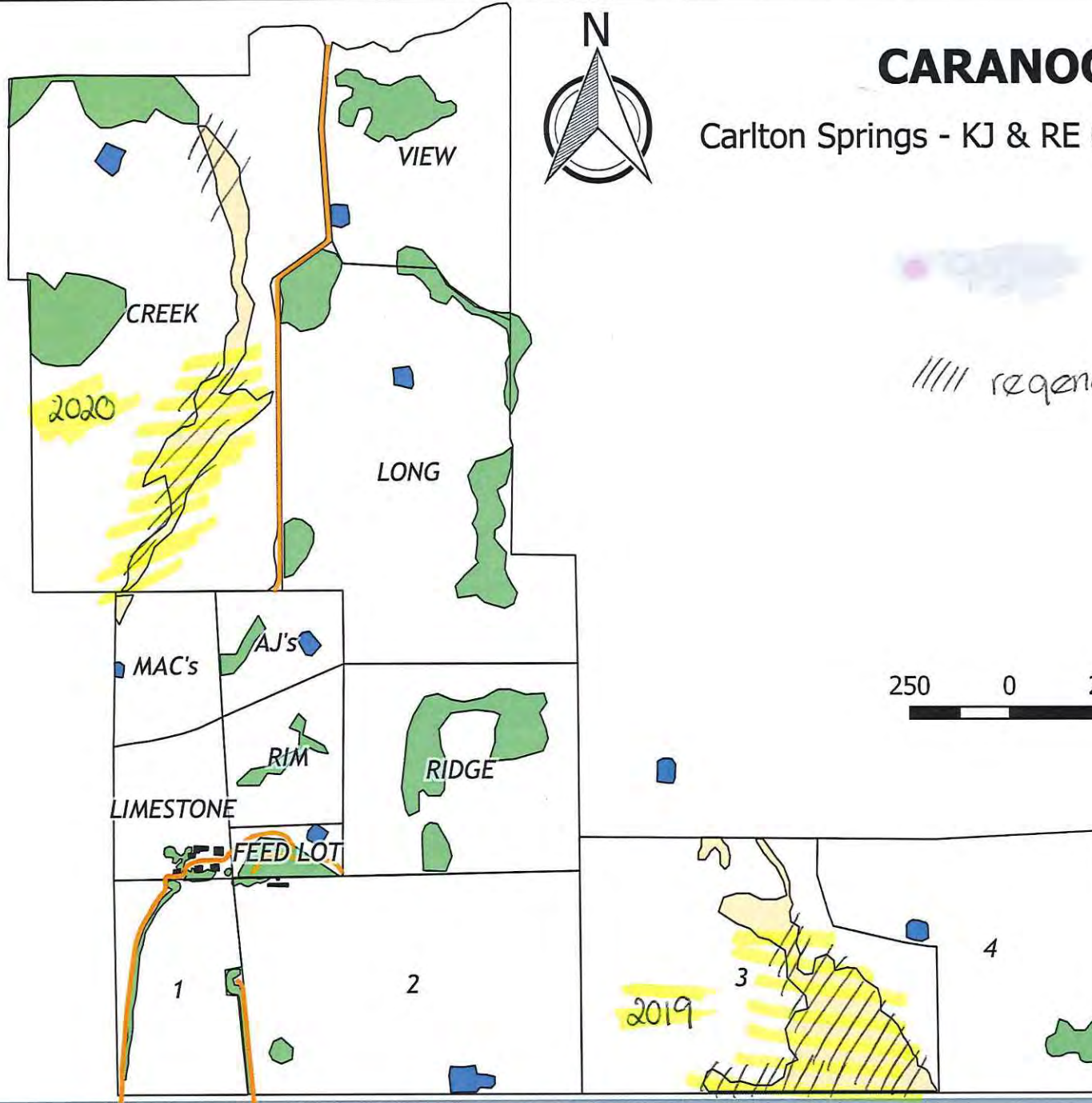

USELESS



February 2018

Page | 32

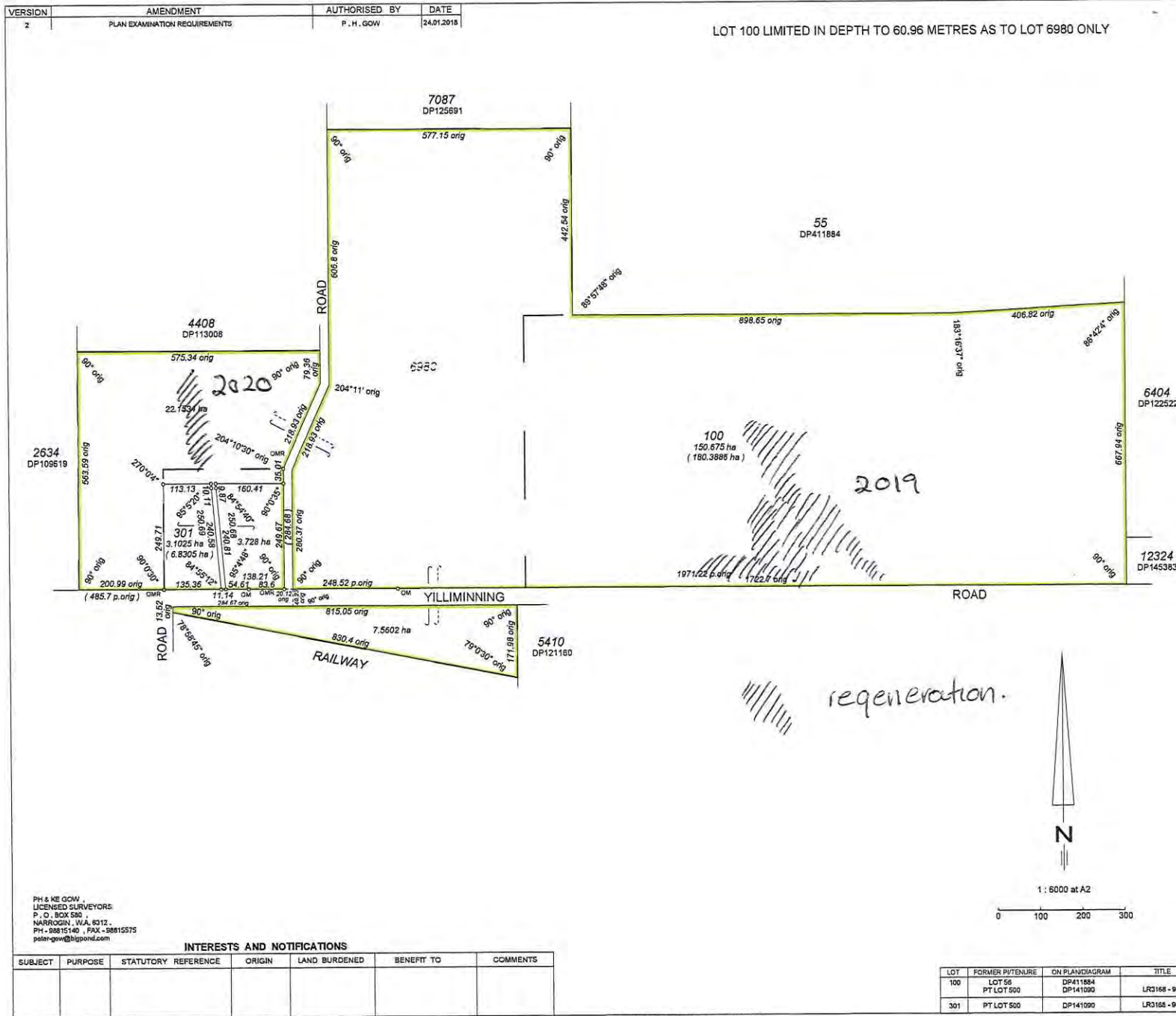

CREEK LINE 2020

For your inform for the fencing materials

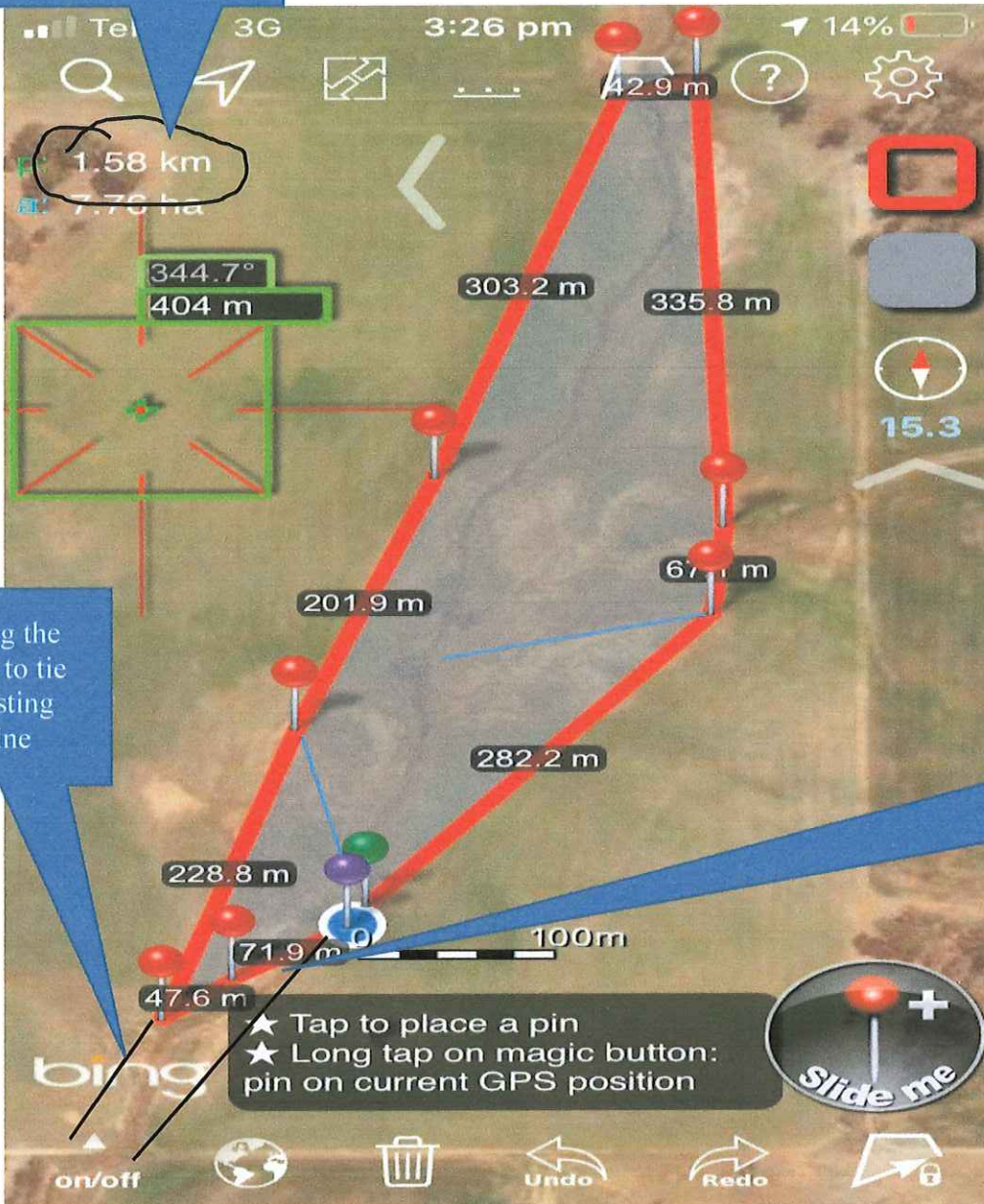

Extending the fenceline to tie with existing fenceline

Allow enough area to get some vegetation established on the east side of the creekline

2020



2020











Plantation and Landcare Services Pty Ltd

ABN 32546652580 ACN 098754271

PO Box 591

Mount Lawley WA 6929

Bill Davey (Forester)

Phone 92718725

Mobile 0429961770

Email bdavey@palservices.com.au

www.palservices.com.au

Taking landcare into the future.....

March 14 2020

Kieran Quartermaine
NARROGIN WA

Saltbush trees and Landcare 2020

Dear Kieran

Great catching up last week attached mapping of the proposed site for 2020.

Thought: wondering if it would be better to take the fence down to the existing fenceline (see map) then come back up the other side avoiding the need to cross the creekline given this could be subject to wash and harder to make stock proof

Species: Trees and shrubs similar to last year but more saltbush there is significant areas of saltland. Try not to fence too close to these areas as this limits the choice of vegetation that can be used, if we can get trees and shrubs established up slope this will prevent encroachment

Area (ha) (areas subject to measuring again after site prep has been completed)	Trees/shrubs saltbush @1000 stems per ha	Site prep. (require linkage tractor will use Dons this year I hope)	Unit cost \$+gst	Total planting cost \$+gst	Total cost \$+gst	Comments
7.7 ha Plantable approx 7.0 ha	7700	525	1.35	10395	10920	Area will be remeasured after site prep completed

2020

Have allowed some 1500-2000 saltbush to be infilled across last years plots mainly next to the road to the tree.

If this looks ok confirm via email as with last year I will raise an invoice for a deposit
Any queries get back to me

Yours sincerely
Bill Davey, Plantation and landcare Services

TREE LIST

From: Bill Davey <bdavey@palservices.com.au>
Sent: Wednesday, 5 August 2020 5:09 PM
To: Keiran Quartermane
Subject: Re: carlton springs 2020

Atriplex amnicola
Atriples nummularia
Casaurina obesa
Callestromen phoeniceus
E sargentii
E spathulate
E loxophleba
E occidentals
Melaleuca hamolosa
M cuticularis
M uncinata
M thyroides.
M laterita

Cheers

Bill Davey
Plantation and Landcare Services
PO BOX 591
Mt Lawley
Western Australia 6929
Ph 08 92718725 Mobile 0429961770
bdavey@palservices.com.au www.palservices.com.au

On 4 Aug 2020, at 12:51 pm, keirancoll@westnet.com.au wrote:

Good afternoon Bill,
Would please supply me with a list of trees you have planted at Carlton Ridge this year and any relevant information in regards to this regeneration project.
I wish to use it as support for a regeneration grant I am applying for

Kind regards
Coll Quartermaine

Xcel Ag WA Pty Ltd ABN: 14 607 591 391
TRADING AS

57-59 Earl Street
Narrogin, WA, 6312
Ph: (08) 9881 5133
Fx: (08) 9881 5144
admin@fwngn.com.au

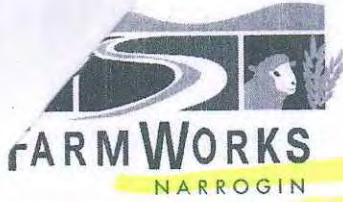

For all of your Ag Chemical, Fertiliser & Farming Supplies

Tax Invoice

Date: 22 Apr 2020 11:34 AM

Invoice No: 63495

Account: 304IAC

Bill To:	CARLTON SPRINGS PO BOX 250 NARROGIN WA 6312 Australia
----------	---

Pho (08) 9881 3303 **Payment Terms**
Mob (0429) 889 838 25TH DAY OF
FOLLOWING MONTH

Product Code	Description	Qty.	Price	Value
9023026	EZI STRAINER Assemblies 80/40	50	105.00	5,250.00

Merchandise:	5,250.00
GST:	525.00
Total Due:	5,775.00
Tendered:	0.00

Account: 304IAC (CARLTON SPRINGS)
Invoice No : 63495
Served By: ASHLEY WILKINS

Outstanding: 5,775.00

PLEASE NOTE OUR BANK ACCOUNT HAS CHANGED BSB: 086-852 ACCOUNT 69-106-7481

* Indicates Item Excludes GST

Xcel Ag WA Pty Ltd ABN: 14 607 591 391
TRADING AS



For all of your Ag Chemical, Fertiliser & Farming Supplies

57-59 Earl Street
Narrogin, WA, 6312
Ph: (08) 9881 5133
Fx: (08) 9881 5144
admin@fwngn.com.au

Tax Invoice

Date: 22 Apr 2020 11:32 AM

Invoice No: 63494

Account: 304VAC

Bill To:	CARLTON SPRINGS PO BOX 250 NARROGIN WA 6312 Australia
----------	---

Pho (08) 9881 3303
Mob (0429) 889 838

Payment Terms
25TH DAY OF
FOLLOWING MONTH

Product Code	Description	Qty.	Price	Value
100353214	STOCKSAFE T LONGLIFE 7/90/30 200M (WARATAH)	18	285.00	5,130.00
100217488	FENCE POST JIO STAR 165CM	400	7.40	2,960.00

Merchandise: 8,090.00
GST: 809.00
Total Due: 8,899.00
Tendered: 0.00

Account: 304VAC (CARLTON SPRINGS)
Invoice No : 63494
Served By: ASHLEY WILKINS

Outstanding: 8,899.00

PLEASE NOTE OUR BANK ACCOUNT HAS CHANGED BSB: 086-852 ACCOUNT 69-106-7481

* Indicates Item Excludes GST

Xcel Ag WA Pty Ltd ABN: 14 607 591 391
TRADING AS



all of your Ag Chemical, Fertiliser & Farming Supplies

57-59 Earl Street
Narrogin, WA, 6312
Ph: (08) 9881 5133
Fx: (08) 9881 5144
admin@fwngn.com.au

Tax Invoice

Date: 15 May 2020 01:47 PM

Invoice No: 63972

Account: 304\AC

Bill To:	CARLTON SPRINGS PO BOX 250 NARROGIN WA 6312 Australia
----------	---

Pho (08) 9881 3303 **Payment Terms**
Mob (0429) 889 838 25TH DAY OF
 FOLLOWING MONTH

Product Code	Description	Qty.	Price	Value
1228620	TIEWIRE-GAL 2.00MM (5) 200MT	1	28.00	28.00

Merchandise:	28.00
GST:	2.80
Total Due:	30.80
Tendered:	0.00

Account: 304\AC (CARLTON SPRINGS)
Invoice No : 63972
Served By: BERNIE MALEY

Outstanding: 30.80

PLEASE NOTE OUR BANK ACCOUNT HAS CHANGED BSB: 086-852 ACCOUNT 69-106-7481

* Indicates Item Excludes GST

Bill To: CARLTON SPRINGS
 PO BOX 250
 NARROGIN
 WA 6312
 Australia

Pho (08) 9881 3303
 Mob (0429) 889 838

Payment Terms
 25TH DAY OF
 FOLLOWING MONTH

Product Code	Description	Qty.	Price	Value
9121635	WIRE PLAIN FLEXABEL MT LONGLIFE 2.5MM 1500M (WARATAH)	2	200.00	400.00

Merchandise: 400.00
 GST: 40.00
Total Due: 440.00
 Tendered: 0.00
Outstanding: 440.00

Account: 304\AC (CARLTON SPRINGS)
 Invoice No : 63773
 Served By: ASHLEY WILKINS
 PLEASE NOTE OUR BANK ACCOUNT HAS CHANGED BSB: 086-852 ACCOUNT 69-106-7481

* Indicates Item Excludes GST

2019
Completed

Attachment 1

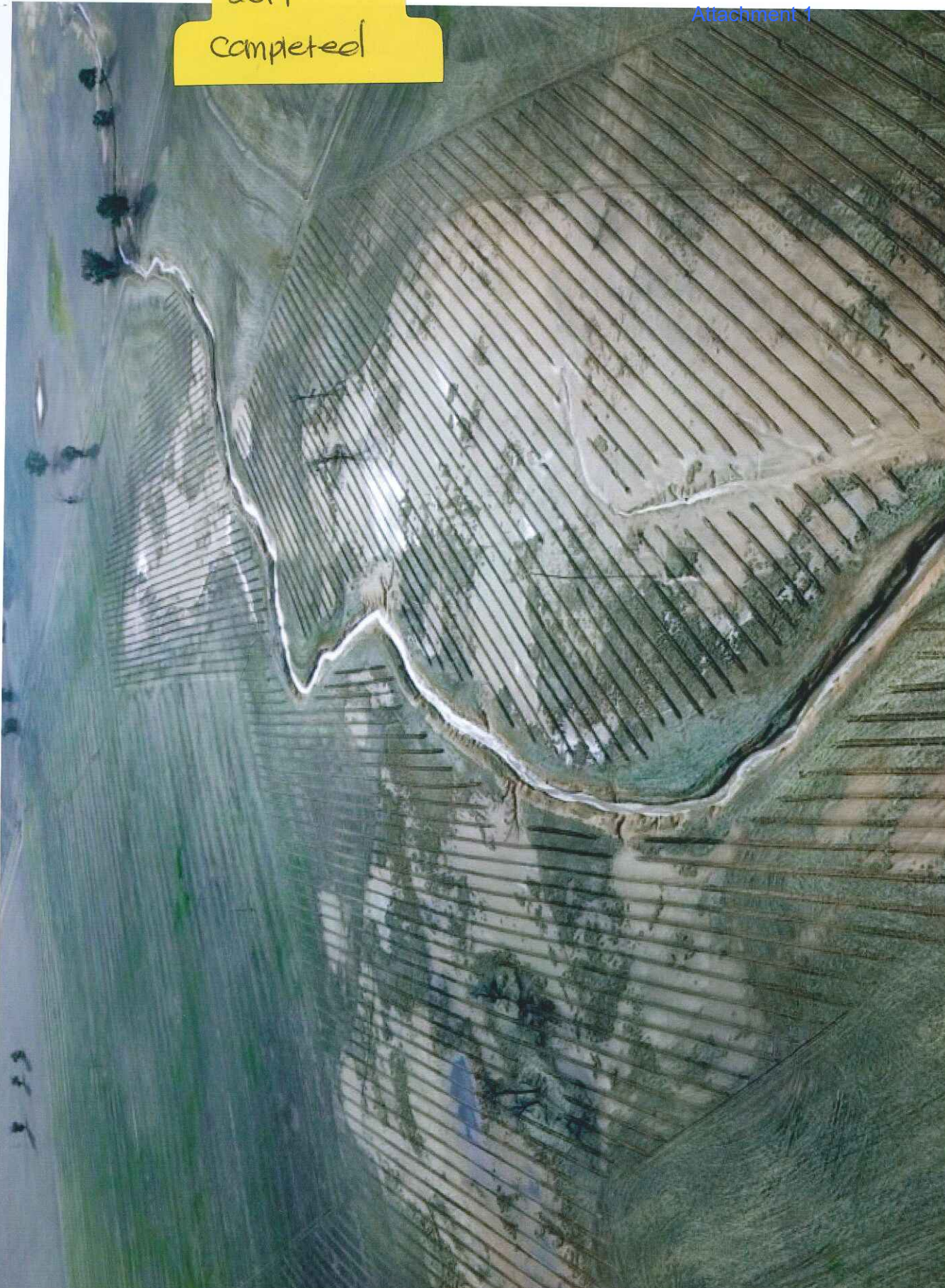



LANDCARE PROJECT FUNDING GUIDELINES (FTRS003)



89 Earl Street
PO Box 1145
Narrogin WA 6312

(08) 9890 0900

www.narrogin.wa.gov.au
enquiries@narrogin.wa.gov.au

CASHIER HOURS:
8:30am – 4:30pm
MONDAY- FRIDAY

The Shire of Narrogin provides funding assistance through the Landcare Project Fund, to rural applicants within the Shire of Narrogin, for the purchase of native plants to be planted on their property. Funding is available up to a maximum of \$5,000, where the applicant demonstrates dollar for dollar spending on native plants for the nominated project.

Round 1 opens 15 July closes 31 August
Round 2 opens 1 February closes 28 February

What will be funded

- Purchase costs of Australian native plants i.e. trees and shrubs where the applicant demonstrates dollar for dollar purchasing of native plants up to \$5,000.

What will not be funded

- Deficit funding or retrospective funding, or funds paid in advance.
- Recurrent expenditure (i.e. salaries and operational costs).
- Proposals where alternative sources of funding are available.
- Maintenance, repairs, installation of, or upgrades to machinery, equipment, fencing or other property infrastructure or assets.
- Maintenance, repairs or upgrades to buildings or property which are the property of the State Government.

Eligibility

- Organisations and individuals are eligible to apply for funding.
- No individual application shall receive in excess of \$5,000 project funding.
- The project must demonstrate the benefit, improvement and outcomes that will be achieved for land rehabilitation or regeneration.
- Projects are required to be completed and acquitted by 30 September of each year.
- Organisations or individuals who have failed to acquit previously received Landcare Project funding within the required timeframe may be ineligible to apply.
- Applications should be submitted using the Application Form, with copies of quotes attached.
- Applications should be addressed to the above and received by the closing date.

Assessment criteria

- Demonstrated capacity to manage and be accountable for the funds and the project.
- Demonstrated cash contribution to the proposed project.
- Funding will be available for the supply of native vegetation ie trees or shrubs to improve salt effected, eroded and other land areas in need of rehabilitation.
- Funding is not available for fencing, however projects demonstrating that the applicant will be supplying and erecting fencing for new vegetation will be viewed favourably.
- Funding will only be available for land outside Narrogin and Highbury town sites, and within the Shire of Narrogin, with no minimum lot size.
- Copies of quotes for materials and services to deliver the project must be provided;
- Provision of a detailed cash project budget showing expenditure and income including project amount requested.
- Demonstrate the extent of and the contribution in cash or in-kind by the applicant.
- Projects that commit to matching dollar for dollar support will be viewed favourably.
- Applications that can demonstrate that materials will be purchased using local businesses will be viewed favourably.
- Compliance with all acquittal requirements for any previous Shire funding received.
- Compliance with appropriate Local Laws, Policies, Acts, Regulations and Standards.

Applicants are encouraged to contact the Shire's Technical Support Officer (Technical and Rural Services) by email to enquiries@narrogin.wa.gov.au or by telephoning 9890 0900 to discuss their project, or to obtain a copy of the Application Form. Click on the link for copy of the [Application Form \(PDF\)](#) or [Application Form \(MS Word\)](#).

10.2.2 FUTURE DEVELOPMENT OF ABLUTIONS AT LOT 103 SMITH STREET

File Reference	5.4.5
Disclosure of Interest	Neither the Author nor Authorising Officer have any Impartiality, Financial or Proximity Interests that requires disclosure.
Applicant	Shire of Narrogin
Previous Item Numbers	10.1.6 - 27 November 2019 10.2.2 - 24 March 2020 10.2.1 - 28 July 2020
Date	16 September 2020
Author	Loriann Bell – Administration Support Office
Authorising Officer	Torre Evans – Executive Manager Technical and Rural Services
Attachments	1. Survey Responses

Summary

Council is requested to consider options regarding the demolition of the existing ablution facility and building of a new public toilet in the same style as Memorial Park, on the site of Lot 103 Smith Street, Narrogin.

Background

The public toilets at Lot 103 Smith Street were identified for replacement in the 2019/20 Budget with an allocation of \$50,000. The Administration was working to complete this project within the financial year that it was budgeted and in August and September 2019 obtained quotes to supply a building for installation at the site.

Design options included a tilt up concrete and steel structure, and galvanised metal frames with Colorbond cladding.

The Administration sought direction from the previous Narrogin District Townscape Committee with regards to colour and design preferences via email, however, the members of the Committee at that time did not support these options and the project was put on hold until the new Townscape Advisory Committee was established.

See over.

Quotes were received for supply only of following four options:

Option 1 – Burton 3 comprising 1 x unisex accessible cubicle and 2 x unisex standard cubicles priced from \$31,000 to \$35,000.



Burton 3 \$31,330



Burton 3 Floor plan

Option 2 - Yarra 3 comprising 1 x unisex accessible cubicle and 2 x unisex standard cubicles priced from \$31,000 to \$35,000.



Yarra 3 \$34,490



Yarra 3 Floor plan

Option 3 – Rebus comprising 1 x standard female cubicle; 1 x standard male cubicle and 1 x accessible cubicle; or 3 x accessible cubicles priced from \$101,900.



Option 3 - Rebus.

Option 4 – Exeloo - 2 x standard unisex cubicle; 1 x accessible cubicle; or 3 x accessible cubicles priced to approximately \$160,000.

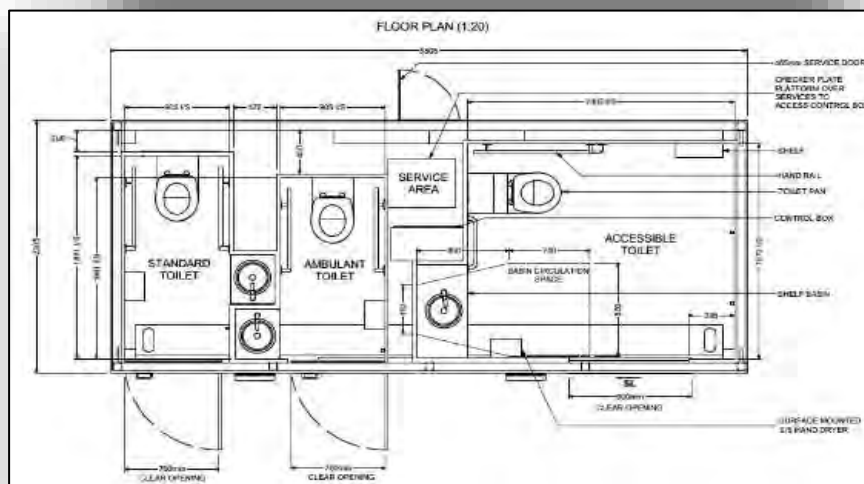
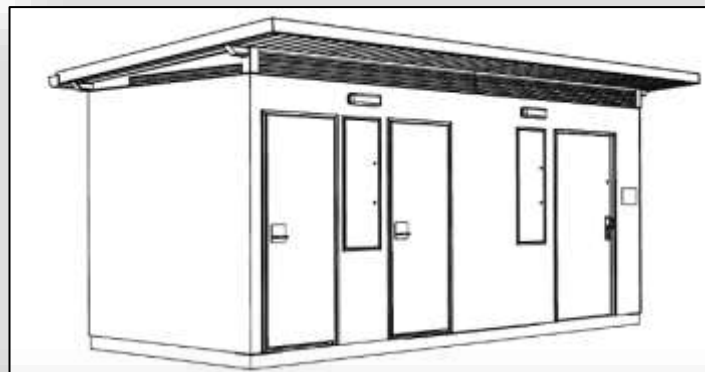

Option 4 - Exeloo Jupiter Triple

At the Ordinary Council Meeting on 28 July 2020, Council resolved:

“That, with respect to the future development of Lot 3 Smith Street- Public Toilet, Council approve that the following three proposals be advertised for community comment by the administration;

- 1. Refurbish the existing ablutions; or*
- 2. Demolish and replace the existing ablutions; or*
- 3. Demolish the existing Smith Street ablutions and upgrade another ablution facility within the Central Business District”.*

Comment

Consultation with the community on this potentially sensitive item was deemed to be an important and necessary step in the decision making process for both the Townscape Committee and Council in ascertaining the future of this much used facility and to enable an informed and holistic decision process.

The Administration published an online survey with links from the Shire’s Facebook page and website, and an advertisement in the Narrogin Observer on 13 August. Additionally, laminated notices were placed on each cubicle wall in the male and female toilets at the Smith Street ablution facility.

The community consultation process received 87 responses which indicated a general preference to retain a public ablution facility at that location and the majority (62%) indicating that the existing facility should be demolished and new rebuild on site. Additional comments by some respondents included requests for:

- a baby change room;
- CCTV;
- additional toilets as the waiting outside in the bad weather is not acceptable;
- unisex toilets and separate urinal; and
- self cleaning and self closing doors.

In 2019 and 2020 the Shire completed two public toilet construction projects of different styles and designs which were based on the requirements of individual locations. The design of the Memorial Park toilets had to be sympathetic to the State Heritage status of the park and the existing pavilion, and required approval by the State Heritage Council of WA. The toilets at May Street needed to meet the needs of the public, but also the participants from visiting sports clubs and codes.

1. May Street public toilets; custom design flat pack, steel construction, 1 x accessible toilet, 2 x standard toilets, 1 x accessible shower and 2 x standard showers, were constructed in 2019/2020 at a cost of approximately \$80,000. Installed by a local contractor.
2. Memorial Park public toilets; bespoke design, brick construction, 2 accessible unisex cubicles were constructed in 2019 at a cost of approximately \$100,000.

Quotes received in 2019 for the Modus flat pack designs of Burton and Yarra were within the amount budgeted in the 2020/2019 Budget, and were considered by the Administration to meet the needs of the public at the Smith Street location. The 2020/2021 Budget contains an amount of \$90,000 for public toilet upgrades in the Narrogin Central Business District. The amount could be used in keeping with the community suggestions for the demolition and replacement of the Smith Street toilets.

At the Townscape Advisory Committee meeting held on 15 September 2020, the Administration recommended to the Committee that the existing facility be demolished and replaced with a custom design flat pack onsite at Lot 103 Smith Street as follows:

That, with respect to the development of Lot 103 Smith Street, the Townscape Advisory Committee recommend that Council:

- 1. Note the overwhelming support from the community to demolish the existing toilets and replace them; and*
- 2. Demolish the existing public toilet; and*
- 3. Purchase and install a custom Yarra 3 type design similar to the recently installed facility at Clayton Oval; and*
- 4. Cost of supply and installation is to a maximum amount of \$65,000.*

The Townscape Committee did not support the Officers' Recommendation and entered into further discussion prior to making an alternate recommendation.

The Committee members discussed various aspects of the Officers' Recommendation, acknowledging the responses received from the community to the online survey. The majority of the members present agreed that the existing toilet should be demolished, and a new bespoke toilet be built on site in the same style as the new toilets in Memorial Park. Two members did not object to a new building being constructed, but noted that this was their second preference, and that refurbishing the existing toilet was their first preference.

There was a general consensus from the Committee that some additional features should be considered, for the aesthetic appeal, safety, and functionality of a new ablution facility should Council resolve one to be built:

- Decorative privacy screen;
- Anti graffiti surfaces;
- Protection from vehicles;
- Baby change facilities/parents room;
- Durable, vandal proof fixtures (e.g. toilet roll holders, sinks etc);
- CCTV;
- Verandah shelter (for people waiting in in hot, wet, cold weather);
- Mural;
- Preferable layout; 1 x unisex accessible with baby change facilities; 3 standard self-contained cubicles.

The Committee made the following recommendation to Council:

“That, with respect to the development of Lot 103 Smith Street, the Townscape Advisory Committee recommend that Council:

- 1. Note the overwhelming support from the community to demolish the existing toilets and replace them; and*
- 2. Demolish the existing public toilet; and*

3. *Build a new ablution facility on the same site and in the same style as the new toilet located in Memorial Park; and Budget permitting, the cubicle layout should comprise;*
- *1 x unisex accessible with baby change facilities; and*
 - *3 standard self-contained cubicles.*
- Cost of supply and installation is to a maximum amount of \$90,000”.*

Consultation

Community comment was invited in accordance with Council Policy 1.14 Community Engagement Policy with an advertisement in the Narrogin Observer on 13 August 2020 and Shire Facebook and website posts with links to an online survey. Additionally, notices were placed on the Shire noticeboards and onsite at the Smith Street public toilets.

Consultation was also entered into with the following:

- Chief Executive Officer;
- Executive Manager - Development and Regulatory Services;
- Executive Manager - Technical and Rural Services;
- Technical Officer - Development and Regulatory Services;
- Narrogin Townscape Advisory Committee; and
- Council.

Statutory Environment

A new or upgraded facility will be in accordance with the Former Town of Narrogin Town Planning Scheme No.2 and adopted Budget.

Policy Implications

Procurement of a new facility and subsequent installation or construction will be in accordance with Council Policy 3.1 Purchasing.

Financial Implications

The 2020/2021 Budget contains an amount of \$90,000 (funded from the Buildings Reserve) for public toilet upgrades in the Narrogin CBD. A design similar to that at Memorial Park but with 2 additional cubicles (one (1) unisex accessible and three (3) standard unisex) will also come at an inevitable additional cost that may not be able to be contained within the Budget of \$90,000.

The approved two (2) toilet unisex accessible design at Memorial Park was quoted at \$70,000 but this did not include sewer installation and path connections, or a allowing for a mural. The Smith Street site also requires demolition of the existing facility, additional fencing / security of the public and also allowance for building fees and design fees.

It should be acknowledged that building a bespoke design facility (similar but different) to the one at Memorial Park will require additional time and may not be able to be concluded in the current budget. Having a draftsman design the proposed requested features including weather protection and anti-graffiti surfaces, engaging the community regarding appropriate murals will all add both time and cost to the project.

An indicative costing for the project proposed by the Townscape Committee, bearing in mind it is not the same floor plan, square metres of construction, or indeed design quoted 12 month ago at \$70,000, would be as follows:

Design (Drafting) Fees	\$4,000
Building Fees	\$500
Sewer connection fees	\$500
Mural Design and Install (depending upon complexity and number of walls	\$5,000
Demolition works and site preparation	\$10,000
Building Contract (estimate)	\$90,000
Contingencies	\$Nil
Total estimate ex GST.	\$110,000

The principle of ablutions being built based on the specification of the Townscape Committee is an indicative cost, therefore of \$110,000, as opposed to the previously quoted proposal recommended by the Administration at \$65,000.

It should be noted that the additional question of CCTV coverage has not been costed with either proposal, and can be addressed as part of a broader review of the CBD CCTV network.

Strategic Implications

Shire of Narrogin Strategic Community Plan 2017-2027		
Objective	3.	Environment Objective (Conserve, protect and enhance our natural and built environment)
Outcome:	3.1	A preserved natural environment
Strategy:	3.1.1	Conserve, enhance, promote and rehabilitate the natural environment
Outcome:	3.4	A well maintained built environment
Strategy:	3.4.1	Improve and maintain built environment

Voting Requirements

Simple Majority

TOWNSCAPE ADVISORY COMMITTEE RECOMMENDATION

That, with respect to the development of Lot 103 Smith Street, Council:

1. Note the overwhelming support from the community to demolish the existing toilets and replace them; and
2. Demolish the existing public toilet; and
3. Build a new ablution facility on the same site and in the same style as the new toilet located in Memorial Park; and Budget permitting, the cubicle layout should comprise of:
 - 1 x unisex accessible with baby change facilities; and
 - 3 standard self-contained cubicles.
4. Cost of supply and installation is to a maximum amount of \$90,000.

OFFICERS' RECOMMENDATION

That, with respect to the development of Ablutions at Lot 103 Smith Street, the Council:

1. Note the overwhelming support from the community to demolish the existing toilets and replace them; and
2. Demolish the existing public toilet; and
3. Purchase and install a custom Yarra 3 type design similar to the recently installed facility at Clayton Oval; and
4. Cost of the total project, demolition. Security screen, supply and installation is to a maximum amount of \$65,000.

Q1 If the Shire were to upgrade a public toilet in the Narrogin CBD, which one would you choose?

Answered: 85 Skipped: 0

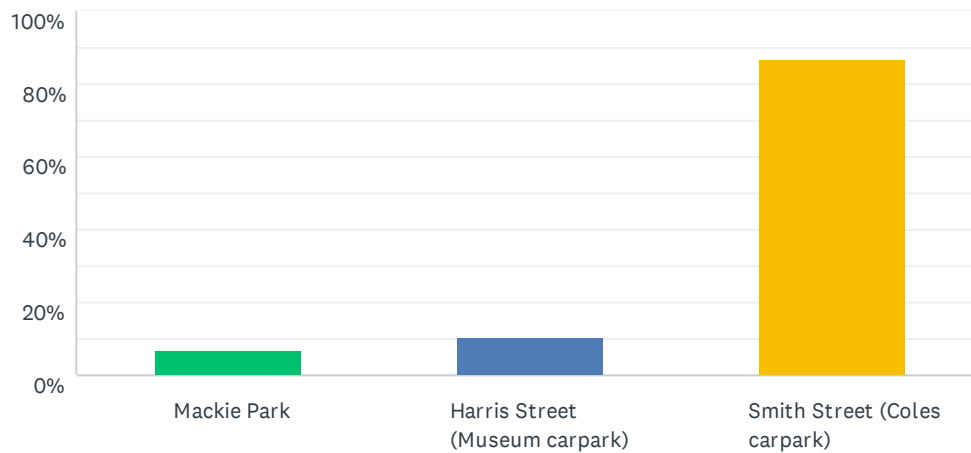

ANSWER CHOICES	RESPONSES
Mackie Park	7.06% 6
Harris Street (Museum carpark)	10.59% 9
Smith Street (Coles carpark)	87.06% 74
Total Respondents: 85	

Have your say on the future development of Smith Street toilets (Coles carpark)

#	PLEASE TELL US WHICH OTHER PUBLIC TOILET YOU WOULD LIKE TO SEE UPGRADED, AND WHY	DATE
1	Car park toilet near museum Tourists that pop into town use it while visiting the museum. Young parents use that area for young kids to run around as there is some lawn and it's central to everything just need fixing up	8/24/2020 4:50 PM
2	Used by many locals and travellers	8/24/2020 9:55 AM
3	The Smith St toilets as they are in a high use area and very handy for out oft owners, parents of small children etc	8/23/2020 7:31 PM
4	Because they are outdated	8/23/2020 11:37 AM
5	Museum carpark as Egerton street is busier with foot traffic after the Coles area.	8/23/2020 11:12 AM
6	Coles carpark. So many seniors, or people with young children would find it very hard to go elsewhere when they come there to shop.	8/23/2020 11:00 AM
7	They are old	8/23/2020 9:18 AM
8	Mackie Park, it doesnt matter what time of the day you go there, there is always water on the floor, resulting in the cuff of you jeans/pants getting wet, or water soaking through your shoes and your socks wet. None of those outcomes are pleasant, and prevent me from using those facilities. There is no option but to use the Smith Street toilets, they are always disgusting, broken, and out of toilet paper, but no other choice as coles, the bakers, butchers and anz bank, dont allow public use of their facilities	8/21/2020 4:16 PM
9	Old and dirty and used by a lot of people. Needs to be upgraded or replaced	8/21/2020 4:11 PM
10	All of them, because they need it!	8/20/2020 12:17 AM
11	Mackie Park as in the middle of the CBD. Toilets are a way that tourists will almost always rate a town. How clean, how well maintained, how funky, quirky, and how functional. All out toilets as infrastructure offer opportunities to impress and create good impressions and memories for visitors and tourists alike. Don't underestimate the value of our toilets and don't forget about seniors and parents with kids who both need accessible toilets nearby to shops and recreational areas.	8/18/2020 8:40 AM
12	The only toilet that doesn't need upgrading is the new one at the memorial park.	8/16/2020 9:09 PM
13	Mackie park, frequently used and in main street so necessary!!	8/13/2020 10:02 PM
14	Memorial Park	8/13/2020 7:24 PM
15	Mackie park both these facilities are near frequented shops and are a great for out of town locals	8/13/2020 7:19 PM
16	Mackie park is also a well used facility	8/13/2020 7:18 PM
17	Smith Street is the one I use the most, given proximity to coles, Bintamilling arcade, Target and the Nursery	8/13/2020 7:13 PM
18	Smith St toilet mist used and most obvious to visitors to town	8/13/2020 6:58 PM
19	Personally, the only public toilet I have used for some considerable time is the Smith Street facility. I am in my seventies and have often needed to use these facilities prior or after having completed my shopping at Coles. I would prefer to see the facility converted to a male urinal and two unisex toilets.	8/13/2020 3:03 PM
20	Why ask for ONE toilet to upgrade and then ask which other one and why? The toilet in Smith Street is regularly used by many people. It's very convenient being so close to Coles.	8/13/2020 2:11 PM
21	Museum because they are used a lot	8/13/2020 1:43 PM
22	Coles is a busy area, parents, children, carers and the elderly all frequent this area every day. Many times I have had to leave coles or Target to use the Smith Street toilets, a young child cannot hold at times, it is NOT permitted to use the staff toilet in Coles. Leaving your trolley full of groceries to quickly go to the toilets near Coles is stressful enough but what if the toilets were further away. Well disaster would likely happen to the child, then would the parents go back into coles to finish their shop or would they have to go home, I reckon they would leave, I	8/13/2020 12:36 PM

Have your say on the future development of Smith Street toilets (Coles carpark)

would have to, meaning those items in the trolley would need to be put back or wasted by a staff member. I have a mother with irritable bowel and if she attends nearby shops she has to ensure there is a close by toilet. She can't walk far at all so a toilet further away would mean she would worry about being in that area of town without a loo closeby. We need to think about those people more likely to need the Smith Street toilets. Walking to a toilet located in another street might be fine for a lot of people, especially for males that don't have the same issues ladies have. We have to think about others not just about what might be fine for us.

23	Mackie Park due to be central to town.	8/13/2020 12:26 PM
24	Harris street (museum car park) easy access Usually my first stop when I come into town,	8/13/2020 7:58 AM
25	Mackie Park as it is probably most used.	8/13/2020 6:47 AM
26	Its shit and need updating	8/13/2020 6:21 AM
27	Harris St: it's in poor condition, It's near bus stop, museum & nearby food outlets	8/13/2020 1:40 AM

Q2 Do you think the Smith Street toilets should be upgraded, or demolished and rebuilt at the same site, or demolished and another facility in the CBD upgraded?

Answered: 83 Skipped: 2

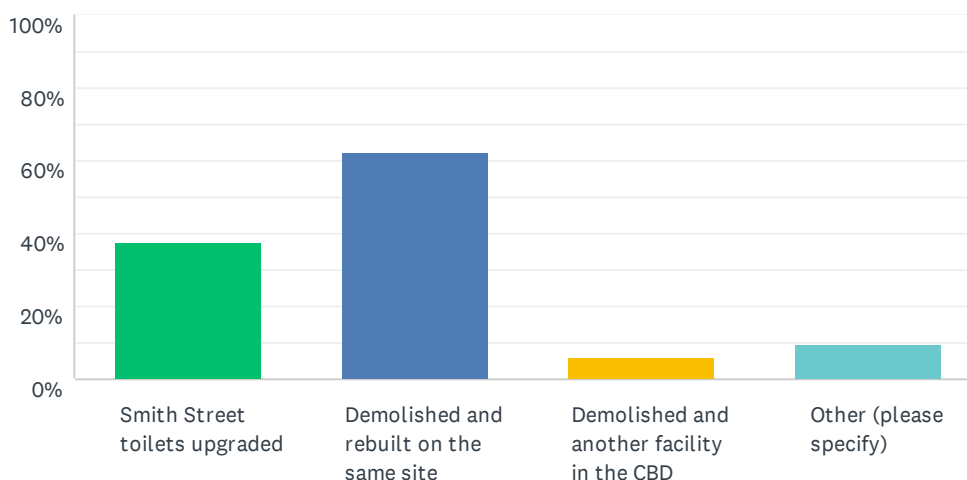

ANSWER CHOICES	RESPONSES	
Smith Street toilets upgraded	37.35%	31
Demolished and rebuilt on the same site	62.65%	52
Demolished and another facility in the CBD upgraded	6.02%	5
Other (please specify)	9.64%	8
Total Respondents: 83		

#	OTHER (PLEASE SPECIFY)	DATE
1	Would like to see temporary facilities close by whilst out of action	8/25/2020 4:00 PM
2	Depends on pricing to demolish and rebuild. If price prohibitive a revamp would be better than nothing. Security cameras might help stop some of the vandalism and antisocial behaviours.	8/24/2020 8:30 PM
3	they need to have more than two toilets, waiting outside in the rain and in public is not comfortable	8/21/2020 4:18 PM
4	Stop wasting money. They are perfectly good toilets. They need gutting, tiling, refurbishing rendering and then some simple public art	8/18/2020 8:41 AM
5	I would prefer a rebuild with a male urinal and two unisex toilets - preferable self cleaning and exit doors opening so that when you have washed your hands (non-touch taps) you can exit the facility without touching possible contaminated door handles!	8/13/2020 3:06 PM
6	These toilets are perfectly functional, they are just really ugly. Upgrade the facade and fixtures.	8/13/2020 2:12 PM
7	I think there is a need for public toilets in the area of Coles but think the site isn't suitable.....antisocial behaviour vandalism and as a woman walking between the nursery fence and men's toilets isn't nice seeing men walking in and out...	8/13/2020 12:29 PM
8	I would like to see the Smith Street Toilet CLEANED several times a day.	8/13/2020 8:12 AM

Q3 Do you think there is a need for a public toilet at Smith Street?

Answered: 82 Skipped: 3

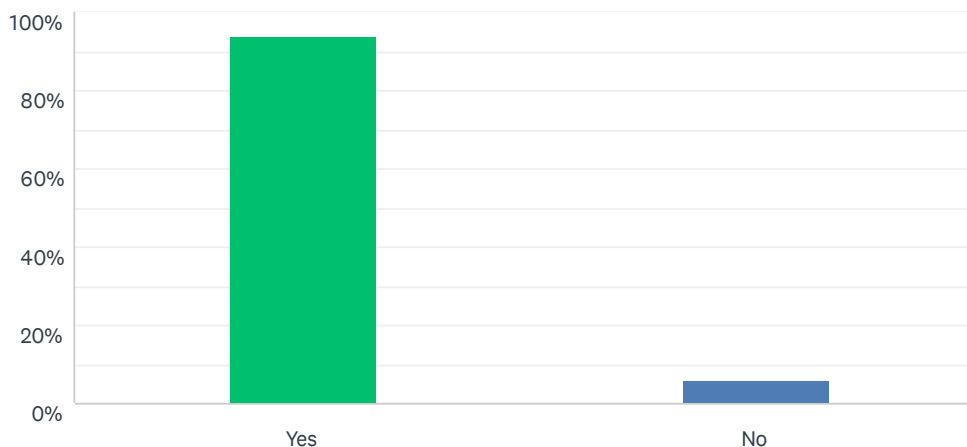

ANSWER CHOICES	RESPONSES
Yes	93.90% 77
No	6.10% 5
Total Respondents: 82	

#	OTHER (PLEASE SPECIFY)	DATE
1	Definitely- I see people use them every time I walk past	8/25/2020 4:00 PM
2	When I had small children I was so grateful for this facility when shopping with them at Coles. I imagine that the elderly or people with mobility challenges also benefit from the closeness of the toilets to the car park and supermarket.	8/23/2020 10:00 AM
3	Thousands and thousands of people got to Coles . They are people with disabilities, they are mostly Mums with kids. Keep those toilets. Don't have them walk 200 metres to the nearest toilet with their prams, strollers, walking sticks. You would do a great disservice to people in this demographic to take the toilets from this site.	8/18/2020 8:44 AM
4	For people that come from out of town and have small children it is a necessity	8/13/2020 7:22 PM
5	None of the retail outlets I deal with in the area have public toilet facilities. It would be unfair to request use of a business facility toilet if you are not a regular customer.	8/13/2020 3:07 PM
6	This is often an emergency stop for me on the way to Coles.	8/13/2020 11:02 AM
7	It is a fair distance to other toilets for those times when you or your kid are in Coles and just have to go.	8/13/2020 3:26 AM

Have your say on the future development of Smith Street toilets (Coles carpark)

Q4 Do you have any other comments or suggestions you would like to share with us?

Answered: 42 Skipped: 43

#	RESPONSES	DATE
1	For me personally I drive 75km with two young children to shop at coles, these toilets are very central and used a lot by us. I dont want to take my kids into a different shop for many reasons.	8/28/2020 7:58 PM
2	Please provide CCTV cameras in the area to cover both the facilities and carparking (thefts or damage). Please also consider touchless options, plenty of lighting, and if necessary, a PIN CODE or FOB key to access the facilities.	8/27/2020 10:16 AM
3	Maybe a change table so parents dont have to change kids in the boot of their car and there is only one change area in the whole of narrogin that i know off and nobody is going to drive all that way to do a nappy change if they are doing shopping	8/25/2020 7:04 AM
4	Please install camera's on entry to stop destruction. Maybe self locking doors at night. Make the doors open and self lock. Spend some money on quality products not cheap toilet roll holders that will fall of the wall and destroy our new toilet block. It's a pain for parents to not have a toilet close by when shopping with kids. If it's taken away they won't be able to finish their shopping	8/24/2020 10:13 PM
5	When grocery shopping with little kids the 'Coles toilets' are easy to get to quickly when needed. It would be a lot harder to leave your trolley at Coles then have to drive to another toilet in the CBD when timing is important especially for younger children.	8/24/2020 8:43 PM
6	Baby changing facilities would be a great improvement	8/24/2020 8:37 PM
7	Smith Street toilets are important as it's a frequent place to go being next to Coles. Sometimes that is the only shop I go to when coming into town and Coles don't have public toilets to use. It is awkward if you only go into a shop to use their toilet.	8/24/2020 3:21 PM
8	many shoppers in town use the toilets i would love to see a mothers room put in there as well so mums have some where to change there bubs	8/24/2020 1:49 PM
9	Please consider the needs of the many people who shop in this area, who are from out of town.	8/23/2020 7:32 PM
10	Coles toilets are used a lot, kids always need to go right when you are doing your shopping. Are these parents suppose to walk all the way down to the park to use toilets ?	8/23/2020 2:28 PM
11	Smith street needs to be upgraded as the area is a major use area 6 days each week.	8/23/2020 11:13 AM
12	Perhaps use stainless steel sinks and toilets so that they are resistant to being vandalised and broken.	8/23/2020 10:02 AM
13	I imagine Smith St toilets has a very high usage & do not recommend demolish & not replacing	8/23/2020 7:52 AM
14	We need these toilets most visitors come to the shopping areas of town Mackie park serves the post office side of town and smith street does the other.	8/21/2020 10:27 PM
15	Please consider upgrading Smith Street toilets as a high priority, those of us that live out of town would greatly appreciate that. It is a well discussed topic that Narrogin has the worst public toilets	8/21/2020 4:22 PM
16	Why don't you put a new block like the ones in Memorial Park	8/21/2020 4:12 PM
17	Please make the upgrade!	8/20/2020 12:17 AM
18	These toilets are used a lot because of coles shoppers and people from out of town.If they get pulled down it not a look for the town when you see people peeing on the ground when they are closed even on weekends.	8/18/2020 4:18 PM
19	Thanks for the opportunity. Be creative, be expansive, get out of the Narrogin ugly thinking with your plain old boring new buildings. You have a new toilet in memorial park and it is pedestrian and boring. The not so new accessible toilets in Gnarojin Park have some style and yet also blend with the environment. Get away from tedious salmon brick, grey paving and bland artwork. If you can call it artwork (Memorial Park)	8/18/2020 8:47 AM
20	These toilets are in an important location. They provide facilities not only for Coles and Target customers but also for Bill and Bens Bakery, the local Butcher, NicNacs, Home Hardware and	8/16/2020 9:11 PM

Have your say on the future development of Smith Street toilets (Coles carpark)

really any business in the arcade. As I have an elderly grandmother, I know that have nearby toilets is a necessity. If there are toilets nearby she is able to spend longer in town, visits more shops etc. But if there isn't one, she often has to go home after her first shop and doesn't venture out again. And who wants to see one of our elderly citizens, or a mother with young children even, struggling to get back in a car to head to a public toilet knowing they won't bother to go back.

21	i feel the smith st toilets should be rebuilt as it is the busiest place in Narrogin 6 days a week , and there needs to be a lot better upkeep .	8/14/2020 2:08 PM
22	The Smith St toilets are used regularly by my family, the children are always needing the bathroom once we get into coles! Having public toilets so close by is convenient and has saved me a lot of stress when they were little because I didn't have to get them to hold on whilst we walked or drove around to the museum toilets	8/14/2020 1:07 AM
23	I think the toilets near Coles are important as they are central to a popular shopping area.... very handy...and thanks for asking!	8/13/2020 8:38 PM
24	Maybe move them to the old veg shop site so that we can have more parking in the coles car park	8/13/2020 7:23 PM
25	Wheelchair accessible toilets at smith Street with a baby change table is what is needed.	8/13/2020 7:14 PM
26	People with urge urinary incontinence find a common trigger for their incontinence is the cold aisle in a supermarket. It is important that toilets close to to Coles for this reason	8/13/2020 7:04 PM
27	Request that Coles contribute to the facility!	8/13/2020 3:08 PM
28	This has gone to townscape several times. Why do you have a townscape committee if you don't take their opinion into account? They are the community's representatives.	8/13/2020 2:13 PM
29	The toilets are required there because of the shopping around there but they need to be upgraded definitely and monitored	8/13/2020 1:44 PM
30	Upgrade the toilets, this day and age make sure there is something to wash hands with.	8/13/2020 12:37 PM
31	Maybe relocate them to the other side of the Coles Carpark	8/13/2020 12:30 PM
32	Does smith street still have opening hours eg 7 am to 7 pm? I have not noticed vandalism. They are very important toilets to me!	8/13/2020 11:05 AM
33	Toilets in Narrogin Nursery and pub are for customers and NOT public toilets.	8/13/2020 8:17 AM
34	Toilets don't have to be fancy and new, just clean. Maybe cameras (obviously not in the actual toilet stall) so vandalism can be wiped out.	8/13/2020 8:14 AM
35	That is a disgusting looking toilet in a ridiculous position. Remove it and upgrade the main st one.	8/13/2020 7:37 AM
36	If people want the toilets to stay, it should become responsibility of Coles as it is mainly their customers who use it.	8/13/2020 7:30 AM
37	For those of us who live out of town easy access to Public toilets is essential!	8/13/2020 7:22 AM
38	Sell to Coles or Demolish and make Coles provide toilets - customers and tourists can use the 3 other public toilets in the CBD.	8/13/2020 6:45 AM
39	Resealing Smith Street	8/13/2020 6:33 AM
40	If I need to use the toilet when down town like at Coles I use that one on smith street and I see it getting use on a regular basis too.	8/13/2020 3:32 AM
41	It would have been helpful if you had included a small mudmap on the location of the toilets. Perhaps it isn't too far from Coles to other toilets? Seeing it on a map may have changed my answer.	8/13/2020 3:27 AM
42	Definitely need these facilities, kids and elderly can't make it from there to the mackie St or Museum toilets when they need to go while shopping, and wouldn't want to risk people urinating where there are no close toilets. The Smith St toilets serve a large amount of businesses and their customers. Baby change facilities are essential too, it's really tough as a	8/13/2020 12:40 AM

Have your say on the future development of Smith Street toilets (Coles carpark)

mum to be shopping, need to change your baby and have to leave your groceries, carry squirming wet bub all the way to the mackie St facilities and then go back to Coles.

Loriann Bell

From:
Sent: Friday, 21 August, 2020 9:55 PM
To: Enquiries
Subject: ICR2021302 - Smith Street Toilets

Hi,

I just wanted to give my input on the future development of the Smith Street toilets.

Considering their close proximity to Coles which would be our busiest business in town I most definitely think these toilets must remain.

Personally I think a demolition and rebuild is required here although if an extensive upgrade could be done at a better cost, this could possibly allow the museum car park toilets to be upgraded as these are atrocious also.

I think the council will receive some very heavy backlash if the Smith Street toilets were removed completely.

Kind Regards

Sent from my iPhone

Loriann Bell

To: Enquiries
Subject: RE: Smith Street Toilets

Friday, 14 August 2020 10:40 PM

To: Enquiries <enquiries@narrogin.wa.gov.au>

Subject: Smith Street Toilets

Hi Dale,

Thank you for the opportunity to comment on the Smith St. Toilets. I believe they badly need to be replaced but I think it would be better if they were moved to the front of Coles car park fronting onto Ensign Street. That would place them further away from the Hotel and the Bottle shop and more exposed to passing road traffic thus giving less opportunity for vandals to do their mischief. Most people shopping at Coles would use these toilets at some stage and I would like to think that Coles should contribute to the costs.

Good toilet facilities are an important service to Narrogin and people expect them to be clean and well maintained and tourist and visitors take note in their impression of the town.

Sincerely

10.3 CORPORATE AND COMMUNITY SERVICES

10.3.1 SCHEDULE OF ACCOUNTS PAID – AUGUST 2020

File Reference	12.1.1
Disclosure of Interest	Neither the Author nor Authorising Officer have any Impartiality, Financial or Proximity Interest that requires disclosure.
Applicant	Shire of Narrogin
Previous Item Numbers	Nil
Date	14 September 2020
Author	Danielle Gannaway – Customer Service Officer/Accounts Payable
Authorising Officer	Frank Ludovico – Executive Manager Corporate & Community Services
Attachments	1. Schedule of Accounts Paid – August 2020 (separate cover).

Summary

Council is requested to note the payments as presented in the Schedule of Accounts Paid – August 2020.

Background

Pursuant to Local Government Act 1995, Section 6.8 (2)(b), where expenditure has been incurred by a local government, it is to be reported to the next Ordinary Meeting of Council.

Comment

The Schedule of Accounts Paid – August 2020 is presented to Council for notation. Below is a summary of activity.

<i>August 2020 Payments</i>		
<i>Payment Type</i>	<i>\$</i>	<i>%</i>
Cheque	\$2,393.43	0.25%
EFT (incl Payroll)	\$786,198.34	81.06%
Direct Debit	\$179,913.70	18.55%
Credit Card	\$1,370.27	0.14%
Trust		
Total Payments	\$969,875.74	100%

<i>Local Spending</i>	<i>\$</i>	<i>%</i>
Local Suppliers	\$201,805.82	20.81%
Payroll	\$442,107.29	45.58%
Total	\$643,913.11	66.39%

The payment schedule has been provided to Elected Members separately and is not published on the Shire of Narrogin website owing to potential fraudulent activity that can arise from this practice.

Printed copies will be available on request at the Administration building and the Library.

Consultation

Executive Management Team

Statutory Environment

Local Government Act 1995, Section 6.8 (2)(b)

Policy Implications

Nil

Financial Implications

All expenditure has been approved via adoption of the 2020/2021 Annual Budget or resulting from a Council resolution for a budget amendment.

Strategic Implications

Shire of Narrogin Strategic Community Plan 2017-2027	
Objective	4. Civic Leadership Objective (Continually enhance the Shire's organisational capacity to service the needs of a growing community)
Outcome:	4.1 An efficient and effective organisation

Voting Requirements

Simple Majority

OFFICERS' RECOMMENDATION

That, with respect to the Schedule of Accounts Paid for August 2020, Council note the Report as presented.

10.3.2 PROPOSED RATING POLICY – CONTIGUOUS LAND USE

File Reference	13.5.4
Disclosure of Interest	Neither the Author nor Authorising Officer have any Impartiality, Financial or Proximity Interests that requires disclosure.
Applicant	Shire of Narrogin
Previous Item Numbers	Nil
Date	3 September 2020
Author	Joshua Pomykala – Governance Officer
Authorising Officer	Frank Ludovico – Executive Manager Corporate & Community Services
Attachments 1. Draft Policy - Rating – Contiguous Land Use 2. Valuer General's Guide to Rating and Taxing Values Published February 2012 3. CONFIDENTIAL Listing of properties affected – provided under separate cover.	

Summary

Council is requested to consider the adoption of a Rating Policy to reflect contiguous land use within the Shire of Narrogin and provide rating relief to genuine farming enterprises or business activities.

Background

The Policy Manual records the standing instructions of Council to the CEO and other employees, regarding the administration and management of various matters. Many policies have their basis in discretionary matters as permitted by the Local Government Act 1995 (LGA), Local Government Regulations or other legislation. The Shire does not currently have guidance on dealing with requests for the contiguous use of land for rating purposes (a Policy).

Comment

The Shire is seeking the adoption of a policy that would reflect the contiguous rating method of land within the Shire. While this is a current practice, the policy outlines the specific criteria that properties must meet in order to be considered for contiguous rating. The policy would also direct the Administration on how the contiguous rating is to be applied.

The policy seeks to ensure that ratepayers are aware of their ability as a ratepayer to have multiple properties under their ownership contiguously rated (subject to criteria). Contiguous rating already occurs in practice within the Shire. An example being large rural holdings, such as 'farms', having multiple lots on one rates notice and, therefore, valued and rated as one assessment.

To be eligible properties rated Unimproved Value (UV) must meet the following criteria:

- The land (lots or locations) is contiguous (share a common border) and in common ownership;
- The land is used and occupied as one holding;
- The common use and contiguity of the land is likely to continue into the future (eg the relevant portion(s) are not marketed for sale); and

- The land parcels, although possibly separated by a road or waterway (such as a river, stream, creek etc.), would otherwise be adjoining.

The criteria for properties rated Gross Rental Value (GRV) proposed is that they must meet the following criteria:

- The land (lots or locations) is contiguous (share a common border) and in common ownership; and either or both of the following also relates:
- Buildings have (due to a past error) been built across the lot boundaries; and / or
- The lots are clearly used, fenced, utilised and occupied and appears as one clear activity or business.

Should a parcel or parcels of the contiguously rated property be sold individually to another landowner, those parcels are no longer eligible to be contiguously rated with the preceding contiguous property. The new landowner can apply to the Shire to have the land contiguously rated with their other land parcels, providing it meets the criteria outlined in the policy.

It is a common practice with in the Shire of Narrogin for properties rated UV and used for farming to be rated contiguously, due to the Shire encouraging the farming industry within the region and reducing cost of the farming enterprise.

There are currently 45 properties rated GRV within the Shire of Narrogin that are contiguously rated. This information provided demonstrates the existing practice that the Shire has applied, without policy guidance, has not been consistent or uniform and potentially deviates from 'industry practice'. The following table shows the breakdown of rating for different properties and areas which are contiguously rated GRV within the Shire of Narrogin:

Rating	Number of Properties
GRV Residential	28
GRV Industrial	11
GRV Commercial	5
GRV Miscellaneous	2
GRV Vacant	1

The Administration notes that those properties which are zoned commercial or industrial benefit from the contiguous rating of the property for operational purposes, therefore would seek to continue the current contiguous rating on the provision that they follow the policy criteria. In other words the existing 11 and 5 properties contiguously rated would continue to receive that benefit.

A large portion of the 28 properties rated GRV Residential will be affected by the policy, with a small number fitting the criteria for contiguous rating of GRV properties, including properties which have been built (in error) across their respective boundaries. It should be noted that the listed properties are those with multiple Certificates of Titles being rated contiguously, as opposed to multiple parcels (lots or locations) on one Certificate of Title.

For clarity, there are two properties within the town site rated as GRV Miscellaneous, being:

Assessment	Location	Zoning	Size of lots (contiguous)	Use	Rating
A230400	2-4 Hansard Street, Narrogin	Residential and additional use	0.1746 ha	Unoccupied	GRV Miscellaneous
A311300	21 Doney Street, Narrogin	Shops and Offices	0.3633 ha	Unoccupied	GRV Miscellaneous

Property 2-4 (Lots 401 & 402) Hansard Street has a shed which has been built across the boundary line between the two lots, and is clearly fenced and previously used as one property for purposes other than residential.

Property 21 (Lots 166 & 167) Doney Street has been used in the past for quasi-commercial endeavours, including being the hub for Visual Arts of Regional TAFE. The property is clearly fenced and previously used as one property. As such, these two properties satisfy the Administration to be continued to be contiguously rated, compliant with the proposed Rating Policy.

If Council was to adopt the proposed policy, the Administration would write to landowners negatively affected by this policy to inform them of the policy, including the financial implications the policy may have on the ratepayer. Landowners may appeal the Administration's determination, by providing the Administration with evidence pertaining to why the parcels being assessed should continue to be contiguously rated.

The Valuer General's Guide to Rating and Taxing Values gives guidance to Local Government Authorities for group rating criteria.

Landowners will be required to provide the Administration with evidence of contiguous use if they are requesting that their landholdings to be contiguously rated, fitting the criteria of UV or GRV. The Administration will ensure that requesting landowners are given the decision made by the Shire for the contiguous rating of their property, and should the request be denied, the reasons stated for the decision.

Consultation

Consultation has been undertaken with the following officers:

- Chief Executive Officer
- Executive Manager Corporate & Community Services
- Manager Corporate Services.

The Administration has also consulted with officers from the State Government Agency, Landgate (the Valuer Generals Office) who have advised that the proposed Policy is consistent with their Guide and the principles of rating equity and application in Western Australia by that Agency.

Statutory Environment

- Local Government Act 1995 – Section 6.26 to Section 6.82
- Local Government (Financial Management) Regulations 1996 – Regulation 56 – Rate notice, content of etc. (Act s.6.41)
- The Valuer General's Guide to Rating and Taxing Values published February 2012 [https://www0.landgate.wa.gov.au/docvault.nsf/web/INF_LG_Rating_and_Taxing_Values_201202/\\$file/Rating-and-Taxing-Brochure_IOT_English.pdf](https://www0.landgate.wa.gov.au/docvault.nsf/web/INF_LG_Rating_and_Taxing_Values_201202/$file/Rating-and-Taxing-Brochure_IOT_English.pdf)

Policy Implications

A new policy is proposed to be adopted.

Financial Implications

There is already an existing practice within the Shire of Narrogin of contiguous rating, particularly those properties rated on the basis of UV, to encourage the farming industry within the region.

Potentially up to 28 properties rated on the basis of GRV Residential will be negatively affected by this policy, should it be adopted. These properties are currently contiguously rated (multiple titles on one rates notice) within the residential area, noting that most of these, in the opinion of the Administration, do not meet the criteria specified within the policy to be rated contiguously moving forward. The implementation of this policy would see an increase in the amount of rates payable to the Shire of Narrogin by the landowners of these properties, through the properties being rated individually. A minimum rate for residential land (in the townsite of Narrogin) for the 20/21 Financial Year is \$1,105 per annum. Indicatively for a full financial year, additional rates per annum of \$26,000 would be levied.

It may also have the potential beneficial flow on effect of creating more residential land zoned placed onto 'the market', therefore able to be bought and 'developed'.

For the properties where a building crosses the boundary of two or more land parcels, the Shire will advise the owners of the policy and encourage the owners to seek amalgamation of the lots.

Strategic Implications

Shire of Narrogin Strategic Community Plan 2017-2027		
Objective	1.	Economic Objective (Support growth and progress, locally and regionally)
Outcome:	1.4	Agriculture opportunities maintained and developed
Strategy:	1.4.1	Support development of agricultural services
Objective	4.	Civic Leadership Objective (Continually enhance the Shire's organisational capacity to service the needs of a growing community)
Outcome:	4.1	An efficient and effective organisation
Strategy:	4.1.1	Continually improve operational efficiencies and provide effective services

Voting Requirements

Simple majority

OFFICERS' RECOMMENDATION

That Council adopt as a policy of Council the draft 'Rating Policy – Contiguous Land Use', contained in Attachment 1 and note that the Administration in giving effect to the Policy, will write to negatively impacted owners, informing them of the decision, and providing them the opportunity to object to the proposal with all objections being referred to the Council for determination.

1.1 Rating – Contiguous Land Use

Statutory context Local Government (Financial Management) Regulations 1996 –
 - r.55 – Rate record, form of etc. (Act s.6.39(1))
 Local Government (Financial Management) Regulations 1996 –
 - r.56 – Rate notice, content of etc. (Act s.6.41)
 Valuation of Land Act 1978
 - Valuer General’s Guide to Rating and Taxing Values (Version: Published February 2012)

Corporate context Delegation 3.5 – Rates Record, Extensions and Objections

History Adopted dd mmmm yyyy

Policy Statement

Contiguous rating, also known as group rating, is the rating of multiple land titles on one rates notice. This method can occur within the Shire, provided the following criteria is met on the land upon which this policy may apply.

1. Unimproved Value

Where the land valuation is Unimproved Value (UV), the following criteria shall be met for the eligibility of contiguous rating:

- 1.1. The land (lots or locations) is contiguous (share a common border) and in common ownership and;
- 1.2. The land is used and occupied as one holding; and
- 1.3. The common use and contiguity of the land is likely to continue into the future (eg the relevant portion(s) are not marketed for sale); and
- 1.4. The land parcels, although possibly separated by a road or waterway (such as a river, stream, creek etc.), would otherwise be adjoining.

The Council’s policy position is that land outside of townsites utilised for genuine farming enterprise should be contiguously rated, to assist in minimising the cost of production, minimise the unplanned breakdown or disaggregation of farmland and to maximise the opportunities for that land to continue to be aggregated for productive agricultural pursuits and purposes.

2. Gross Rental Value

Where the land valuation is GRV, contiguous rating is not permitted unless:

- 2.1. The land (lots or locations) is contiguous (share a common border) and in common ownership; and either or both of the following also relates;
- 2.2. Buildings have (due to a past error) been built across the lot boundaries; and / or
- 2.3. The lots are clearly used, fenced, utilised and occupied and appears as one clear activity or business.

The Council’s policy position is that land in townsites should not be contiguously rated, as to do so encourages the practice of holding land for speculation. This pushes prices up and inhibits the use of land designated for industrial, commercial or residential development being utilised for those purposes.

Adjoining owners’ vacant residential zoned land, that is not ‘built’ over the boundary line or developed and used as a tennis court or manicured garden, will not be supported for contiguous rating.

If the required criteria is met, the Shire will write to Landgate (The Valuer General) to request the contiguous rating of the affected titles on behalf of the owner.

Where the Chief Executive Officer determines that land does not meet the criteria for contiguous rating, the landowner will be given a right of appeal to the Council.

– End of Policy

Notes

An example of contiguous rating on land rated UV is a farming property which comprise a number of lots/locations that are under common ownership and used contiguously as one large holding and farming operation.



VALUER GENERAL'S Guide to RATING AND TAXING VALUES

Revised July 2015

INTRODUCTION

This brochure describes the Valuer-General's role in providing valuations used by rating and taxing authorities.

The following information is not intended to alter the meaning, intent or application of the *Valuation of Land Act 1978* (the VLA), or the sections and definitions contained therein. In the case of any inconsistency the provisions of the VLA and Regulations prevail.

ABOUT PROPERTY & VALUATIONS

In accordance with the provisions of VLA the Valuer-General (VG) is required to maintain valuation rolls of rateable and taxable land throughout Western Australia. These rolls are periodically provided to rating and taxing authorities.

On behalf of the VG, Property & Valuation Services, Landgate (the Western Australian Land Information Authority), conducts general valuations (revaluations) and makes interim valuations as required.

The types of values made are:

1. Unimproved Value (UV), and
2. Gross Rental Value (GRV).

UV's are used by:

- the Office of State Revenue, Department of Treasury and Finance as a base to assess land tax;
- local governments to determine council rates, mainly in rural and fringe urban areas.

GRV's are used by:

- the Water Corporation, Country Water Boards and some local governments for the determination of sewerage and drainage rates;
- all local governments for the determination of council rates in urban areas;

- the Fire & Emergency Services Authority of WA for the assessment of the emergency services levy;
- other rating authorities such as licensed water resellers in regional areas.

WA ratepayers rely on the VG for the provision of **fair, impartial and equitable** valuations. The VG ensures that these rating and taxing values are independently determined by reference to the property market at the date of valuation and not to any predetermined rating outcome.

VALUATION ROLLS

Under the VLA, the VG is required to ensure that valuation rolls issued after a general valuation are complete, accurate and as current as possible. Valuation rolls are a formal record of the value of all rateable or taxable land in the State. They include sufficient information to identify land and the date at which the rating and taxing authorities must apply the value. Separate valuation rolls are maintained for GRV's and UV's.

Copies of the relevant valuation rolls are supplied to rating and taxing authorities and are available at **Landgate Cloisters** for public inspection. (Refer to contact details).

GENERAL VALUATIONS

The VLA empowers the VG to conduct general valuations on the GRV basis within WA at such times and frequency as he considers necessary and for UVs annually. This requires the State to be divided into valuation districts for which valuation rolls must be maintained.

Valuation districts are constituted at local government level for GRV purposes whereas for UVs the State is constituted into only one valuation district.

Valuation rolls are maintained by making periodic general revaluations. All land recorded in the rolls are of a UV and a GRV basis.

GRV general valuations are currently carried out on a triennial basis in the Perth metropolitan area and every 3-5 years in country areas of the State.

UV's are determined annually.

The making of a general valuation must be notified for public information by advertisement in one issue of each of two newspapers circulating in the area and by a notice published in the *Government Gazette*. The notice will specify:

- the valuation district concerned;
- the date of valuation and when the values come into force;
- rating or taxing authorities required to use the valuations;
- place and time where copies may be inspected;
- the manner in which an objection may be made to any valuation.

DATE OF VALUATION

The **date of valuation** in relation to a general valuation is fixed by the VG.

Unimproved values are determined annually relative to sales and rentals that are negotiated in the market place at or close to the date of valuation, which is set at 1 August prior to the date of adoption of 30 June in the same financial year.

Gross rental values are determined once every 3 – 5 years and the date of valuation is 1 August in the year in which the general valuation is commenced.

UNIMPROVED VALUE

UV is defined in the VLA and in some cases it is a statutory formula. As a broad guide the following applies:

Within a Townsite

For land situated within a townsite the UV is the **site value** of the land. In general this means the value of the land as if it were vacant with no improvements except **merged improvements**. Merged improvements relate to improvements such as clearing, draining and filling.



Outside a Townsite - Rural

The UV of land outside a townsite is valued as if it had no improvements. In this case the land is valued as though it remains in its original, natural state, although any land degradation is taken into account.

If the UV cannot reasonably be determined on this basis, it is calculated as a percentage of the value of the land as if it had been developed to a fair district standard but not including buildings. This percentage is prescribed (where it applies) by the VG from year to year and is currently 50%.

Exceptions

There are certain exceptions to the above for which the VLA provides a statutory formula for calculating the UV – such as a fixed rate per hectare or a multiple of the annual rent.

Exceptions include Mining Tenements, leases under the *Land Administration Act* (such as for grazing) Agreement Acts, and land held under the *Conservation and Land Management Act*.

Strata Titles

Section 62(1) of the *Strata Titles Act* provides that for UV the VG must value the whole of the land subject to a strata plan as a single parcel in single ownership. The rating and taxing authority is required to apportion the value in proportion to the unit entitlement, which is shown on the registered strata plan.

Section 62A(2) of the *Strata Titles Act* provides that each lot in a survey-strata scheme shall be valued as a separate parcel of land.

UV Valuation Methodology

Market based UV's are determined by reference to the land market at the date of valuation. All sales relevant to the predetermined date of valuation are investigated and where considered necessary, the parties interviewed.

Unsuitable sales, such as between related parties or those with special circumstances, are discarded. By this process, a fair and reasonable criteria is established for the fixing of values.

GROSS RENTAL VALUE

In the VLA a GRV is defined as follows:

GRV means the gross annual rental that the land might reasonably be expected to realize if let on a tenancy from year to year upon condition that the landlord were liable for all rates, taxes and other charges thereon and the insurance and other outgoings necessary to maintain the value of the land.

A GRV is determined on the basis that the rental **includes** outgoings such as rates and other property expenses.

As most commercial rentals are negotiated net of outgoings these need to be added to the net rental to equate to the statutory definition.

The introduction of the Goods and Services Tax (GST) has impacted on the determination of GRV. Where property rental payments are subject to GST, they represent a tax payable by the property owner and are included in the GRV.

Where an annual rental cannot reasonably be determined, the GRV becomes the **assessed value**. Assessed value is defined in the VLA as a percentage applying to the capital value of land within a particular class.

Residential land for which no rental value can be determined is valued on the basis of 3% of its total **capital value from 1 July 2011**. Assessed value for land designated for other uses is assessed on the basis of 5% of its total capital value.

Land used for residential purposes only must be valued on the basis of rental value. Any other land with a relatively low rental value in comparison to its capital value may be valued as if it were vacant land.

GRV Valuation Methodology

A database of rental evidence is assembled from information obtained from a variety of sources.

A schedule of properties rented at the date of valuation is prepared for the area to be valued.

The rented properties are inspected and the rents analysed (for example deductions for furniture included in the letting).

Unsuitable lettings, such as those between related parties, are discarded so that the final list is acceptable as the basis for the determination of fair gross rentals as illustrated by actual market dealings.

From the analysis of actual rentals the fair gross rental of each property is established, after making allowances for any special features or detriments.

The GRV normally represents the annual equivalent of a fair weekly rental. For instance a GRV of \$15,600 represents a weekly rental of \$300.

INTERIM VALUATIONS

Valuation rolls are amended between general valuations to take account of changes that occur to land and property during a financial year. Typical instances include the subdivision of land, a change in the use of the land, new buildings being erected or improvements to existing buildings.

Values are amended to reflect the changed circumstances and to ensure the values are correctly co-ordinated with surrounding land or property. This is achieved by revaluing the land on the assumption that it existed in its amended form at the time of the last general valuation of the district.

The amended value (interim value) comes into force from the date of the change in circumstances and is supplied to rating and taxing authorities for any necessary re-assessment of the annual rates and charges.

GROUP VALUES

UV's

Valuation principles and court precedent provide that parcels of land meeting all of the following requirements may be valued as one holding for rating and taxing purposes.

- contiguous (touching) and in common ownership.
- used and occupied as one holding.
- Contiguity and use will continue into the future
- Basis of valuation confirmed by sales evidence.

For example, a farming property comprising a number of lots/locations all in common ownership and being used as one large holding, will normally receive a single value.

GRV'S

GRV values are determined on the basis of actual or probable occupation, provided that:

- Where there is more than one occupation within a single ownership, individual values are determined and then aggregated into a total value;
- Where an actual and continuing occupation extends across more than one lot a single value is determined for the whole of the land;
- Where a single occupation extends across more than one ownership the single value is apportioned to the separate ownerships.

OBJECTIONS AND REVIEW

Under the VLA any person liable to pay a rate or a tax has the right to object to the values. Property owners having concerns over a valuation, are advised to contact Property & Valuations as many queries can be resolved over the telephone without the need to lodge a formal objection.

An "Objection to Valuation" form, including additional information, is available from the VG.

Formal objections are only accepted from the owner of the property or his authorised agent except where the occupier is the person named in the rating records of the rating and taxing authority as the owner.

The objection must be lodged **within 60 days** from the issue of a rating or taxing notice, or **within 60 days** from notification of the general valuation in the Government Gazette. While the VG may accept objections outside this period it is more likely the matter will be treated as an informal query without rights of review.

The VG may grant an extension of time in which to lodge a valid objection, however the onus is on the objector to establish reasonable cause for such an extension to be granted.

Objections can be made in writing to the VG and should include:

- The full address of the property (including lot numbers or location numbers where applicable).
- The reference or assessment number and name of the issuing authority.
- The valuation to which the objection relates and the type of valuation (UV or GRV).
- For GRV, a description of the property and any improvements.
- The detailed reasons and evidence in support of the grounds for objection.
- A copy of the rate or tax notice which will assist in identification.
- Details of the objector's name, postal address and telephone number are to be supplied.

Once an objection is received, a valuer will contact the objector to arrange an inspection of the property. A response, including the decision to allow or disallow the objection, will be served in writing.

An objector who is dissatisfied with the decision may have the decision reviewed by the State Administrative Tribunal (SAT). A request to have the decision referred to the SAT must be served on the VG within **60 days** of the service of the VG's decision (or such further period as the VG, before or after the expiry of that time, for reasonable cause shown by the person, allows).

DEFINITIONS

The following definitions are drawn from the VLA:

Townsite

- All land within the metropolitan region;
- All land within a district that is a city or town outside the metropolitan region;
- Any land that is currently a townsite within the meaning of the *Land Administration Act 1997* or any Act repealed thereby; and

- Any land, including privately owned subdivided land, in an area that has been, or is to be regarded as having been, constituted a townsite, and given a name, under section 10 of the *Land Act 1933*.

Site Value

Site value of land means the capital amount that an estate of fee simple in the land might reasonably be expected to realize upon sale assuming that any improvements to the land, other than merged improvements, had not been made and, in the case of land that is reserved for a public purpose, assuming that the land may continue to be used for any purpose for which it is being used or could be used at the date of valuation.

Merged Improvements

Merged improvements means any works in the nature of draining, filling, excavation, grading or levelling of the land, retaining walls or other structures or works for that purpose, the removal of rocks, stone or soil and the clearing of timber, scrub or other vegetation.

Rating and Taxing Authority

Rating and taxing authority means any person entitled under any Act to assess any rate or tax in respect of land.

Assessed Value

Assessed value of land means such percentage of the capital value thereof as may from time to time be prescribed. This percentage is fixed by Regulation.

Capital Value

Capital value of land means the capital amount which an estate of fee simple in the land might reasonably be expected to realize upon sale - provided that where the capital value of land cannot reasonably be determined on such basis, the capital value of such land shall be the sum of, first, the unimproved value of the land, and, secondly, the estimated replacement cost of improvements to the land after making such allowance for obsolescence, physical depreciation and such other factors as are appropriate in the circumstances.

Vacant Land

Vacant land means land on which there are no improvements other than merged improvements.



Contact details

Business hours – Monday to Friday from 8:30am to 5pm

General Enquiries:

Perth Metropolitan Region and Regional WA

1 Midland Square

Midland WA 6056

Ph: +61 (0)8 9273 7373

Email: vs@landgate.wa.gov.au

Mail: PO Box 2222 Midland WA 6936

South West Region

9th Floor Bunbury Tower

61 Victoria Street Bunbury WA 6230

Ph: +61 (0)8 9721 0800

Email: bunburyvs@landgate.wa.gov.au

Mail: PO Box 177 Bunbury WA 6231

Objections and Reviews:

Legislation requires that your completed objection form and supporting documents should be lodged within 60 days of the issue date on your rate or land tax notice. You can use any of the following methods:

Postal Address: The Valuer-General, LANDGATE, PO Box 2222, Midland WA 6936

In person: LANDGATE - 1 Midland Square, Midland WA 6056

Email: vs@landgate.wa.gov.au

Objection forms and more information is available at www.landgate.wa.gov.au

Frequently asked questions

Can I discuss my concerns before lodging an objection?

Prior to lodging a formal objection your property valuation can be discussed with a Landgate valuer by phoning +61 (0)8 9273 7373. Many issues can be resolved without the need lodge a formal objection.

Who may lodge an objection

The *Valuation of Land Act 1978* makes provision for "any person liable to pay any rate or tax assessed in respect of land, who is dissatisfied with a valuation of such land made under the Act, may serve upon the Valuer-General or any rating or taxing authority a written objection to the valuation". The Act also extends the right of objection to the authorised representative of such a person.

How long do I have to make an objection and can I get an extension?

The objection must be lodged within 60 days after the issue of a rating or taxing notice or notification of the making of the valuation in the Government Gazette.

The Valuer-General has the discretion to accept objections beyond the 60 day time frame. If you want to lodge an out of date objection you must provide detailed reasons why the objection is late. The Valuer-General will then determine whether to accept the objection.

How do I know if a decision on my objection has been made?

As soon as is practical, you (or your agent) will be advised in writing of the decision made in relation to your objection.

Can I appeal the decision of the Valuer-General?

If you are dissatisfied with the Valuer-General's decision you may, within 60 days of the service of notice of that decision (or such further period as the Valuer-General, 'before or after the expiry of that time, for reasonable cause shown by you, allows) serve on the Valuer-General a notice in writing requiring that the valuation is referred to the State Administrative Tribunal (SAT) for review. You are not required to contact the SAT beyond advising the Valuer-General that you wish it to be referred.

Once the SAT receives the Valuer-General's referral the SAT will write to you confirming the matter and will also provide you with information regarding the conduct of the review process.

10.3.3 REQUEST FOR CONTIGUOUS RATING OF LOT 3 DELLAR STREET AND LOTS 4, 922 & 923 MAY STREET, NARROGIN

File Reference	A340191, A340192
Disclosure of Interest	Neither the Author nor Authorising Officer have any Impartiality, Financial or Proximity Interests that requires disclosure.
Applicant	Mr Grant Froome
Previous Item Numbers	Nil
Date	9 September 2020
Author	Joshua Pomykala – Governance Officer
Authorising Officer	Frank Ludovico – Executive Manager Corporate and Community Services
Attachments	<ol style="list-style-type: none">1. Request for Contiguous Rating.2. Aerial View of Lots 3, 4, 922 and 923.

Summary

A ratepayer has requested their four (4) lots to be contiguously rated within the Narrogin town site. The recommendation to Council has been formed based on the criteria set out in the Draft Rating Policy – Contiguous Land Use.

Background

The ratepayer has applied to have their four adjoining lots to be contiguously rated. Previously, the ratepayer was contiguously rated for three lots, being 479, 922 and 923. Lot 479 Dellar Street, Narrogin (Plan No: P222895, Certificate of Title 991/83) was later subdivided into a further two lots, resulting in the formation of Lot 3 Dellar Street, Narrogin (Plan No: P414158, Certificate of Title 2966/735) and Lot 4 May Street, Narrogin (Plan No: P414158, Certificate of Title 2966/736).

Previously, the ratepayer received one rates notice with the three original lots 479, 922 and 923 (contiguously rated). However since the subdivision of Lot 479 the ratepayer has received two rates notices, separately for Lots 3 and 4. This error arose when the Administration was provided incorrect data from Landgate on the valuation roll, resulting in the Lot 922 May Street, Narrogin (Plan No: P301249, Certificate of Title 1133/582) and Lot 923 May Street, Narrogin (Plan No: P301249, Certificate of Title 862/6) being subsequently cancelled. The ratepayer, therefore, has received rating for two lots, rather than the existing four.

In schedule G2019/9 received from Landgate, the Administration was advised (following the subdivision) that VEN 838070 was to be deleted. VEN 838070 contained Lot 479 (P222895), Lot 922 (P301249) and Lot 923 (P301249). VEN 838070 was to be replaced with VEN 2082745 (containing Lot 3 on P414148) and VEN 2082746 (contains Lot 4 on P414148). The new VEN, however, did not include Lots 922 and 923, subsequently causing the deletion of these lots within the system and not being replaced.

The ratepayer contacted the Administration in 2020 to request that the four lots be contiguously rated, as they have been in the past prior to the subdivision. Should this occur, the ratepayer would receive one rates notice for the four lots.

The Shire's Administration is currently following up the matter regarding the VEN numbers with Landgate, to ensure that Lots 922 and 923 are reinstated on the system and the Shire provided with valuations.

Comment

Once the Administration is provided with the VEN for Lots 922 and 923, the four lots will be reinstated on the system with the correct data. As such, the four adjoining lots will each have separate valuations. The ratepayer has requested for all four lots to be contiguously rated as one, however the current Draft 'Rating Policy – Contiguous Land Use' sets out the required criteria for contiguous rating of GRV Residential properties.

The draft policy states:

"The Council's policy position is that land in town sites should not be contiguously rated, as to do so encourages the practice of holding land for speculation. This pushes prices up and inhibits the use of land designated for industrial, commercial or residential development being utilised for those purposes.

Adjoining owners' vacant residential zoned land, that is not 'built' over the boundary line or developed and used as a tennis court or manicured garden, will not be supported for contiguous rating."

As all four lots are zoned residential, the policy indicates that the vacant residential land, in this case being lots 4, 922 and 923, cannot be contiguously rated for the reason stated above. As such, the criteria of the 'Rating Policy – Contiguous Land Use' has not been met.

The Shire will ensure that the affected landowner is advised of any change in the rating of the properties, including Council's decision for the application, and their right of appeal.

Consultation

Consultation has been undertaken with the following officers:

- Chief Executive Officer
- Executive Manager Corporate & Community Services
- Manager Corporate Services.

Statutory Environment

- Local Government Act 1995 – Section 6.26 to Section 6.82
- Local Government (Financial Management) Regulations 1996 – Regulation 56 – Rate notice, content of etc. (Act s.6.41)
- The Valuer General's Guide to Rating and Taxing Values Published February 2012 [https://www0.landgate.wa.gov.au/docvault.nsf/web/INF_LG_Rating_and_Taxing_Values_201202/\\$file/Rating-and-Taxing-Brochure_IOT_English.pdf](https://www0.landgate.wa.gov.au/docvault.nsf/web/INF_LG_Rating_and_Taxing_Values_201202/$file/Rating-and-Taxing-Brochure_IOT_English.pdf)
- Draft Rating Policy – Contiguous Land Use (if adopted in the previous agenda item).

Policy Implications

In the previous agenda item Council is being asked to consider a policy that assesses the contiguous use of land.

That policy indicates that if land which is rated GRV, is to be contiguously rated in must meet the criteria of the following:

- The land (lots or locations) is contiguous (share a common border) and in common ownership; and either or both of the following also relates:
- Buildings have (due to a past error) been built across the lot boundaries; and / or
- The lots are clearly used, fenced, utilised and occupied and appears as one clear activity or business.

Additionally, the Policy states that adjoining vacant residential land which is not 'built' over the boundary line, or actively used as one residential property, will not be supported for contiguous rating.

Financial Implications

If all four lots are contiguously rated, the ratepayer will only receive one rates notice comprising the four lots, and a valuation provided by the Valuer General to contiguously rate them.

If the application is rejected, the ratepayer will receive four separate rates notices, each assessment being representing the individual lots as outlined previously. Each lot will hold an individual valuation and the ratepayer will be required to pay four separate rates amounts.

Strategic Implications

Shire of Narrogin Strategic Community Plan 2017-2027		
Objective	1.	Economic Objective (Support growth and progress, locally and regionally)
Outcome:	1.4	Agriculture opportunities maintained and developed
Strategy:	1.4.1	Support development of agricultural services
Objective	4.	Civic Leadership Objective (Continually enhance the Shire's organisational capacity to service the needs of a growing community)
Outcome:	4.1	An efficient and effective organisation
Strategy:	4.1.1	Continually improve operational efficiencies and provide effective services

Voting Requirements

Simple Majority

See over.

OFFICERS' RECOMMENDATION

That with respect to the request of the landowner to have Lot 3 Dellar Street and Lots 4, 922 and 923 May Street, Narrogin, contiguously rated, Council reject the application for all four lots to be included in the contiguous rating on the basis that all four lots do not fit the criteria outlined in the Rating Policy – Contiguous Land Use and advise the applicant of his appeal rights.

G.A. FROOME

[REDACTED]

[REDACTED]

[REDACTED]

[REDACTED]

The Chief Executive Officer
Shire of Narrogin
Mr Dale Stewart

Ref: Rates Assessments A340191, A340192

I write to request a deferment of the payments for the above assessments pending the result of current investigations.

You will probably not be aware of my situation, the assessments are currently under investigation by the Shire rates consultant. This is due to the wrong information being given to the Shire by Landgate in 2019.

In 2018/19 I had Lot 479 (No 6 Dellar St) subdivided into two lots, to create Lot 3 (No 6 Dellar St) and Lot 4 (No 33 May St). I have two other lots on May Street (922 and 923). Landgate advised the Shire that the three original lots 479, 922 and 923 had been subdivided to create two lots, Lot 3 and 4.

Previously my assessment was done as "contiguous use", and I was issued with one assessment only (479, 922, 923). Now I am issued with two assessments (3 and 4) and no reference is made to lots 922 and 923.

The Shire rates consultant, Ms Louise Sequerah, is dealing with Landgate to have the situation corrected and also brought back to one assessment - "contiguous use", for the total landholding. Copies of her emails etc are attached.

As the amount owing is over \$4,000, I will find it difficult to be able to find the money to pay by the due date. I am a pensioner on a fixed income. I was previously able to budget for the \$1,800 or so for the single assessment. With the new multiple assessments at over \$4,000 this will not be possible.

If I can wait until the consultant has resolved the situation and, it is reverted back to single assessment, which should be around the same G.R.V. I would be in a financially viable position to pay the amount owing.

Should you require any further information or explanation, please contact me without hesitation.

Trusting that this request will receive favourable consideration.

Yours faithfully

A handwritten signature in black ink, appearing to read 'G. Froome', with a long, sweeping horizontal stroke extending to the right.

Grant Froome
13 August 2020

C.C: Shire President L Ballard

F.Y.I.**Subject: Lots 3, 4, 922 & 923 - Rateable Assessments****From: Rates Consultant <Consultant@narrogin.wa.gov.au>****To: "froomes@westnet.com.au" <froomes@westnet.com.au>****Cc: Thomas Baldwin <rates@narrogin.wa.gov.au>****Fri, 31 Jul 2020 01:17:49 +0000**

Dear Grant

Once again please accept my apologies for the delay in resolving this issue.

Council was advised by Landgate, a division of the Department of Lands and Administration, that you had restructured your lots and that your original assessment was to be split (subdivided) into two new assessments. When doing this they advised that only lot 3P414158 & 4P414158 remained.

Based on your query I have done a search on Landgate's Certificate of Titles and I can see that

Lot 479P222895 Certificate of Title 991/83 was cancelled and replaced with

- Lot 3P414158 Certificate of Title 2966/735

- Lot 4P414158 Certificate of Title 2966/736

Lot 922P3012149 Certificate of Title 1133/582 is still active

Lot 923P301249 Certificate of Title 862/6 is still active.

I will contact Landgate and ask them to reassess this advice with a view to

- Reinstating lots 922 & 923

- Group rating lots 3, 4, 922 & 923 into one assessment.

Landgate advises that queries on valuations can take up to 40 days to respond to. With the adjustment schedule advising Council taking up to another 30 days.

As soon as we receive official advise I will let you know.

Regards**Louise Sequerah****Rates Consultant****Mobile: 0400 201 156**

Enquiries (08) 9890 0900

89 Earl Street, Narrogin

All correspondence to:

PO Box 1145 Narrogin WA 6312 - or

enquiries@narrogin.wa.gov.auwww.narrogin.wa.gov.au

Shire of Narrogin Disclaimer:

This transmission, including any attachments, is confidential and is intended solely for the individual or entity to whom it is addressed. If you are not the intended recipient, please contact the Shire of Narrogin by return email. You should not read, print, transmit, use, disseminate, forward, or copy this transmission, including any attachments to this transmission. You should only retransmit or commercialise the material if you are authorised to do so. The Shire of Narrogin does not represent that this communication or any attachment is free from computer viruses or other faults or defects and will not be liable for any loss or damage, including direct, consequential or economic loss or damage however caused.

03/03/2020

FW: We have received your email:VEN 838070, 2082746 & 2082745 - Missing Lots and Group Rating Request CRM:00152076

Subject: FW: We have received your email:VEN 838070, 2082746 & 2082745 - Missing Lots and Group Rating Request CRM:00152076

From: Rates Consultant <Consultant@narrogin.wa.gov.au>

To: "froomes@westnet.com.au" <froomes@westnet.com.au>

Cc: Thomas Baldwin <rates@narrogin.wa.gov.au>

Fri, 31 Jul 2020 01:35:57 +0000

Dear Grant

For your information, this application has been lodged. I will advise you once we have further details.

Regards

Louise Sequerah

Rates Consultant

Mobile: 0400 201 156

Enquiries (08) 9890 0900

89 Earl Street, Narrogin

All correspondence to:

PO Box 1145 Narrogin WA 6312 - or

enquiries@narrogin.wa.gov.au

www.narrogin.wa.gov.au

Shire of Narrogin Disclaimer:

This transmission, including any attachments, is confidential and is intended solely for the individual or entity to whom it is addressed. If you are not the intended recipient, please contact the Shire of Narrogin by return email. You should not read, print, transmit, use, disseminate, forward, or copy this transmission, including any attachments to this transmission. You should only retransmit or commercialise the material if you are authorised to do so. The Shire of Narrogin does not represent that this communication or any attachment is free from computer viruses or other faults or defects and will not be liable for any loss or damage, including direct, consequential or economic loss or damage however caused.

Sent: Friday, 31 July 2020 9:30 AM

To: Rates Consultant <Consultant@narrogin.wa.gov.au>

Subject: We have received your email:VEN 838070, 2082746 & 2082745 - Missing Lots and Group Rating Request CRM:00152076

Thank you for your email.

Please note the current estimated time to complete an Interim Valuation is 40 working days.

If you have a general enquiry, we will respond within 3 working days.

Should you require further information, please contact our Customer Service team on 61+ (0)8 9273 7373 quoting reference number LG8-146293-Q2M9.

Regards

Valuation Services

Landgate

Landgate

This e-mail and any files transmitted with it are intended only for the use of the addressee(s). It may contain information that is confidential and privileged, in which case neither is intended to be waived or lost by mistaken delivery to you. If you are not an intended recipient, any use, interference with, disclosure, distribution or copying of this material is unauthorised and prohibited. If you receive this e-mail in error, please notify the sender by return e-mail and delete the message and any attachments from your system. Unless specifically indicated, this e-mail does not constitute formal advice or commitment by the sender or the Western Australian Land Information Authority (Landgate). Information in this message not relating to the official business of Landgate shall be understood as neither given nor endorsed by it. It is your responsibility to check any attachments for viruses and defects before opening or sending them on. Landgate's liability is limited to re-supplying affected attachments.

[REDACTED]

Thomas Baldwin
Rates Officer
Shire of Narrogin

Sir,

I write in reference to the receipt of an adjustment to rates and charges for my landholding on May Street.

As you would be aware, previously, the holding consisted of 3 lots, conjoined and rate assessed as "contiguous use" (Assessment No A129900).

I recently subdivided one of the lots (No 479) to form two smaller lots. These became Lots 3 and 4.

Lot 3 contains the existing house, sheds and improvements.

Lot 4 is a vacant paddock.

The other two lots in the assessment, Lot 922 and Lot 923, remain as is. that is, vacant paddocks.

As it now stands, all four lots are still conjoined, their use is the same, their appearance is the same, they still share a common boundary fence and they still share a common firebreak.

Despite the subdivision of one of the Lots, nothing has changed.

Therefore, I request that the previous assessment as "contiguous use" is re-instated to overcome the need for a rates and charges adjustment.



G.A.Froome
Proprietor
26 July 2020

COPY

For your information -
from the letter and rate notices sent to me:

1. Land Id's 479, 922 and 923 had been subdivided to create new land id's 3 and 4.

How can you subdivide 3 into 2.

The new assessment was created only for Lots 3 and 4.

What happened to 922 and 923.

2. Lot 3 contains the house and improvements and is assessed for minimum (unimproved) rate. Assessment A340191.

Lot 4 is vacant land - i.e. a horse paddock, but has been assessed as an improved lot with services etc. It's GRV is \$13,000, Assessment A340192. I can't see anyone paying me \$250 per week to keep their horse in my paddock.

3. Furthermore, the subdivision was completed in May 2019 and the duplicate titles were issued then. I subsequently received the next rate notice in August 2019, still in the old lots and as "contiguous use" assessment. Why wasn't this situation picked up before August 2019 and sorted out?

I was first advised of the re-assessment in November 2019 and spoke to Shire Officer Tahnee Smart, who advised me that she would discuss the matter with Landgate in an effort to resolve it.

I have not heard back from her to this date, so I assumed that it had in fact been resolved. It appears, now, not to be the case.

I also received a letter from the Shire advising of the new street address numbers for the new lots, in November 2018, so the Council was well aware of the situation earlier than when advised by Landgate (2019).

ATTACHMENTS

Survey Plans - Before and After

Copies of Council rate notices for reference

Copies of Landgate aerial photos of Lots.

BEFORE

Quigley St

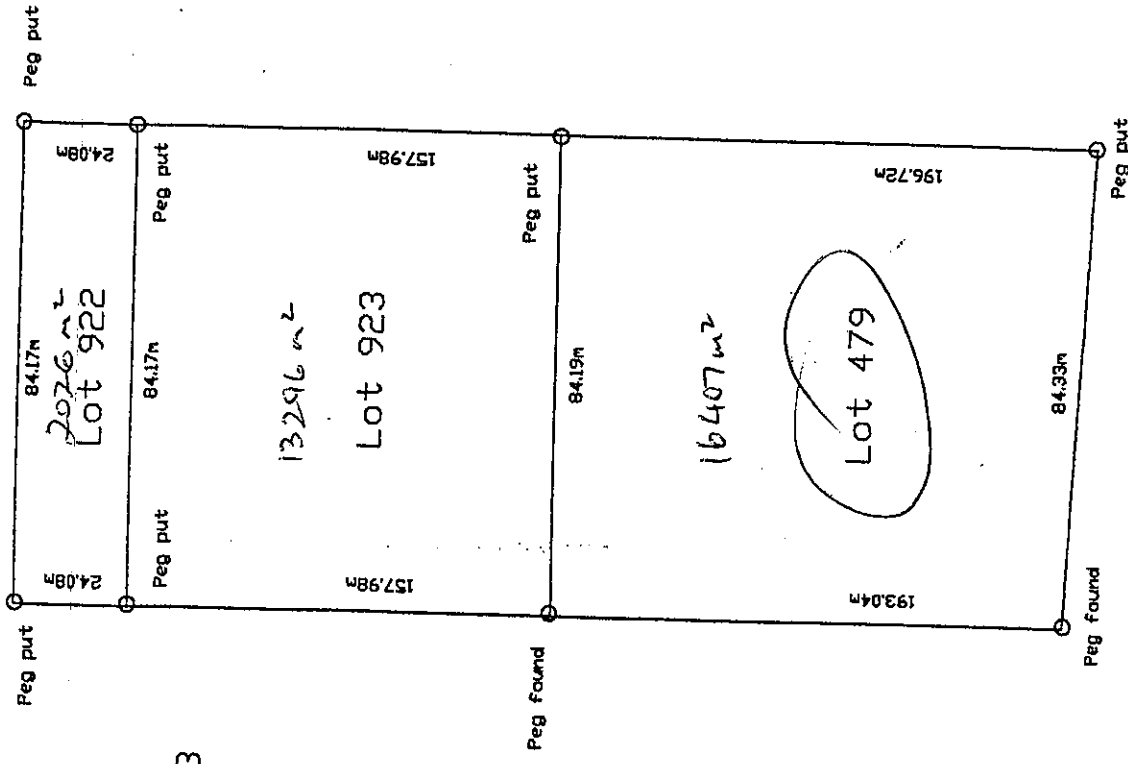

PH and KE GDW (Licensed Surveyors)
 PO Box 580 Narraggin WA
 ph 98815140 fax 98815575

May St

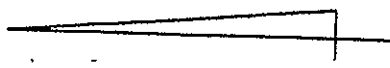

North

Not to Scale 24/09/09

Dellar St

Lot 473

Lot 2

AGTEL

PH and KE GOW (Licensed Surveyors)
PO Box 580 Narrogin WA
ph 98815140 fax 98815575

May St

Quigley St

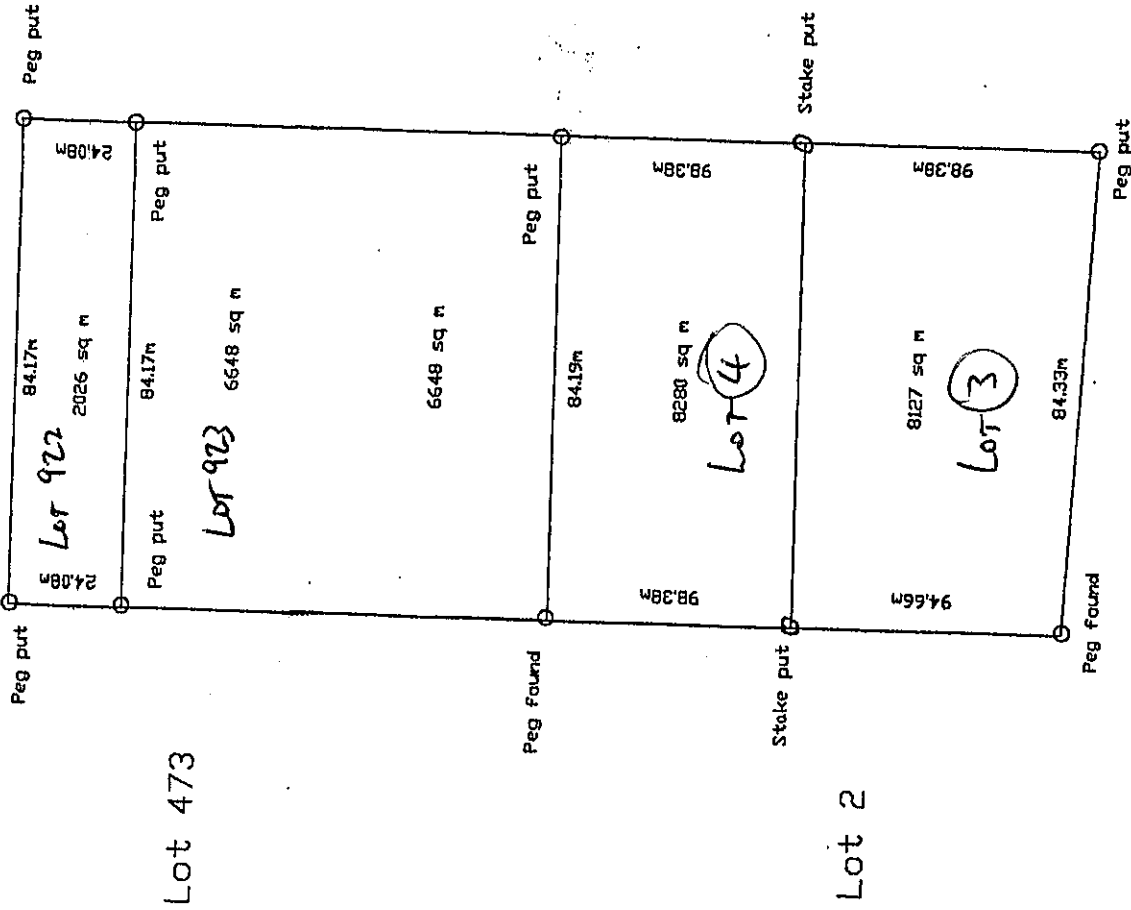

North

Not to Scale 24/09/09

4047 sq m = 1 acre

Dellar St

Aerial View of Lots 3, 4, 922 and 923



10.4 OFFICE OF THE CHIEF EXECUTIVE OFFICER

10.4.1 COMMUNITY CHEST GRANT APPLICATIONS

File Reference	15.1.1
Disclosure of Interest	Neither the Author nor Authorising Officer have any Impartiality, Financial or Proximity Interests that requires disclosure.
Applicant	Shire of Narrogin
Previous Item Numbers	Nil
Date	15 September 2020
Author	Loriann Bell – Administrative Support Officer
Authorising Officer	Dale Stewart – Chief Executive Officer
Attachments	1. Community Chest Applications

Summary

The Community Chest 2020/2021 Round 1 opened on 15 July 2020 with an amount of \$100,000 approved by Council to assist eligible groups with recovery projects and programs owing to the COVID-19 crisis. Council is requested to support the seven recommendations made by the Community Chest Grants Reference Group at the meeting held on 8 September 2020.

Background

Some applicants from Round 2 of the Community Chest Grants Fund 2019/2020 reported difficulties with contractors, and restrictions imposed due to COVID-19 as prohibiting factors to completing their projects and acquitting their grants by 30 June 2020. Therefore the amount of \$15,250 was requested to be carried over from 2019/2020 to the 2020/2021 Budget. This was not carried over as a separate amount, but rather is to be deducted from the \$100,000.

After deducting \$15,250 from the \$100,000 allocated in the 2020/2021 Budget, there remains a balance of \$84,750 for Round 1 and Round 2 applications.

Comment

Applications for Round 1 closed on 31 August 2020 and 17 applications were received requesting cash totalling \$70,135.23. There are two requests for in-kind support; Narrogin Agricultural Society for venue hire at the Narrogin Regional Recreation Centre; and an unspecified amount from the Rotary Club of Narrogin. Proposals should demonstrate benefit to the Narrogin community.

The assessment criteria was amended to enable recipients from the previous two financial years to be eligible, furthermore the maximum amount that could be applied for was increased from \$2,500 to \$5,000.

Below is a summary of the amounts of cash and in-kind requested by the applicants, and the amount carried over from previous rounds and the balance remaining for Round 2 in February 2021.

	Summary of Community Chest Applications	Community Chest 2020/2021	Cash	In-kind Request	Amount recommended by officer	Amount recommended by Reference Group
	2020/2021 Community Chest	100,000.00				
	2018/2019 Unacquitted/carried over	15,250.00				
	Balance	84,750.00				
1	Menshed Narrogin Inc		3,849.00	0	3,849.00	3,849.00
2	Narrogin Cottage Homes Inc		5,000.00	0	5,000.00	5,000.00
3	Narrogin Croquet Club Inc		2,248.00	0	2,248.00	2,248.00
4	Highbury District Tennis Club Inc		4,427.50	0	4,427.50	0
5	Highbury District Community Council Inc		4,213.83	0	4,213.83	4,213.83
6	Narrogin RevHeads Inc		2,500.00		2,500.00	2,500.00
5	Narrogin Golf Club Inc		4,156.90	0	4,156.90	0
7	Upper Great Southern Hockey Association Inc		2,400.00	0	0	0
8	Narrogin Gymnastics Club Inc		5,000.00	0	5,000.00	5,000.00
9	Avon Community Services Inc		2,500.00	0	2,500.00	2,500.00
10	Rotary Club Narrogin		5,000.00	0	5,000.00	5,000.00
12	Narrogin Primary School P&C Inc		5,000.00	0	5,000.00	5,000.00
13	Narrogin Agricultural Society Inc		4,000.00	200.00	4,000.00	4,200.00
14	Eagles Sporting Club Inc		4,840.00	0	4,840.00	2,000.00
15	Narrogin Blue Light Unit		5,000.00		0	0
16	West Coast Jet Sprint Club Inc		5,000.00	0	0	0
17	The Salvation Army - Narrogin Corps		5,000.00	0	0	0
	Total		70,135.23	200.00	52,735.23	41,510.83
	Available for Round 2	43,329.17				

The Council is requested to consider the applications using the Assessment and Eligibility Criteria in the Guidelines below. The Assessment criteria was amended to enable recipients from the previous two years to be eligible.

What may be funded

- Professional fees and charges associated with an event or project (e.g. entertainment, adjudicators, printing, fixed equipment, skilled labour).
- Expenses associated with the production of an event or project (e.g. equipment hire, materials, advertising, venue hire).

What will not be funded

- Deficit funding or retrospective funding.
- Recurrent expenditure (i.e. salaries and operational costs).
- Proposals where alternative sources of funding are available.
- Maintenance, repairs or upgrades to buildings or property which are privately owned or are the property of the State Government

Eligibility

- Only incorporated not for profit community organisations are eligible for support through the Shire's Community Chest program.
- No individual application shall receive in excess of \$5,000 (cash or in kind).
- The applicant group must be able to demonstrate substantial community support for the project.
- Evidence of the association's incorporation should be provided with the application.
- Projects are required to be completed within the financial year of receiving the grant.

Assessment criteria

- Applications should be submitted using the Application Form, with copies of quotes attached.
- Applications should be addressed to the above and received by the closing date.
- Demonstrated capacity to manage and be accountable for the funds and the project.
- Demonstrated cash, donated and in-kind contributions to the proposed project.
- Copies of quotes for materials and services to deliver the project.
- Membership of the organisation is primarily Shire of Narrogin residents.
- Aims and objectives of the organisation benefit primarily the Narrogin community.
- Provision of a detailed cash budget showing expenditure and income including grant amount requested.
- Demonstrate the extent of community involvement and the contribution in cash or in-kind by the organisation.
- Compliance with all acquittal requirements for any previous Shire funding received.
- Compliance with appropriate Local Laws, Policies, Acts, Regulations and Standards.

Applications requesting cash totalling \$70,135.23 have been received from 17 eligible organisations for projects including:

1. Narrogin Menshed Inc

The Menshed submitted two applications for two separate projects totalling \$3,849.

The first application is to purchase a new fridge valued at \$1,049 to replace the old one that was acquired second hand several years ago.

In the second application they are seeking \$2,800 cash in advance to purchase a vehicle hoist to install on the premises. The Menshed is planning to open on Saturdays and have the hoist available

for use by community members, for a modest fee. The second application is seeking the funds to be paid in advance.

The applicant has indicated they will provide \$350 in-kind (volunteer labour) to the projects.

2. Narrogin Cottage Homes Inc

Narrogin Cottage Homes is seeking \$5,000 towards the cost of governance and administration training for their volunteer Board members. It is anticipated the training will provide the members with a sound knowledge of the core duties and legal responsibilities that apply to Board members in the Not For Profit sector.

The applicant has indicated they will provide \$850 cash toward the project.

3. Narrogin Croquet Club Inc

The Narrogin Croquet Club is seeking \$2,248 to upgrade the clubroom kitchen with a new stove and rangehood and new floor coverings in preparation for the Croquet Club's 100th anniversary in 2024.

The applicant has indicated they will support the project with \$1,700 cash and \$300 in-kind (volunteer labour).

4. Highbury District Tennis Club Inc

The Highbury Tennis Club is seeking \$4,427.50 to cover the cost of a Bird Nest Swing for installation in Wilbur Park, adjacent to the Tennis Club. The Tennis Club, together with the Highbury District Community Council, have undertaken a number of projects over the last couple of years which have enhanced the appearance and function of the shared grounds at the Highbury Hall.

The applicant has indicated they will support the project with cash of \$68.80 and in-kind (volunteer labour) estimated at \$200, in addition to the donation of equipment, materials and tools.

The project will need to be installed professionally and comply with all relevant codes.

The members of the Reference Group believed the proposal submitted by the Highbury District Tennis Club could be funded through the Shire's annual Budget. The details are noted in Recommendation 6 of 7.

5. Highbury District Community Council Inc

The Highbury District Community Council is seeking \$4,213.83 towards the cost of modifications at the Highbury Hall toilets. The applicant has identified a problem with windblown rubbish in the toilets, the proposed work will provide solid doors at the entrances, painting the inside and outside of the building and raised garden boxes at the front of the building. Under the terms of the Draft Lease, these modifications are the responsibility of the tenant.

The applicant has indicated they will contribute \$750 in-kind (volunteer labour) to the project.

6. RevHeads Inc

Narrogin RevHeads Inc have requested \$2,500 to purchase marquees to provide additional shade for patrons at the annual RevHeads event held in November each year. The one off purchase will save the Club thousands of dollars in hire fees that they normally spend for shade structures for each event.

The following applicants have requested cash in advance to completing their proposed projects.

7. Narrogin Golf Club Inc

The Narrogin Golf Club is seeking \$4,156.90 cash in advance of their proposed project to purchase equipment that will be used to remove the honky nuts from the greens. The Narrogin Golf Club will be the host club for the State Sand Greens 2021 competition which will attract over 200 players over the four day event, and many visitors to the town.

The applicant has indicated they will support the project with \$2,000 in-kind (volunteer labour) to clean the course with the equipment in preparation for the competition in 2021.

The Reference Group did not support the application for the equipment purchase, but they agreed there was a greater benefit to the Shire by a cash sponsorship of the State Sands Green event in 2021. Details are noted in Recommendation 3 of 7.

8. Upper Great Southern Hockey Association Inc

The Upper Great Southern Hockey Association is seeking \$2,400 cash in advance towards the cost to host a Fixtured Hockey Round on the weekend of 10-12 September 2020. UGSHA will partner with Holyoake to coordinate the Round to recognise R U OK?

As a result of the recent COVID crisis and restrictions, UGSHA identified a need for mental health support within the community following reports that alcohol consumption had increased for some members of the community. The events proposed will include a workshop for coaching and administrative staff where mental health literacy and suicide awareness will be presented and disseminated.

The Shire of Narrogin supported the UGSHA Junior Hockey Carnival with budgeted funds in the financial years of 2016/2017 and 2018/2019.

The applicant has indicated they will support the project with \$100 cash and \$1,200 in-kind (volunteer labour) and \$500 sponsorship.

The Applicant has indicated that the event will take place on 10-12 September 2020. The Ordinary Council Meeting is scheduled for 22 September 2020, therefore the Council's recommendation to approve or decline the application will be made after the proposed event. The Community Chest Guidelines state that retrospective, or deficit funding will not be funded.

The Reference Group did not support this application, details of the alternate recommendation are noted in Recommendation 5 of 7.

9. Narrogin Gymnastics Club Inc

The Narrogin Gymnastics Club is seeking \$5,000 cash in advance towards the total cost of \$20,926 to install new under beam safety flooring in the gym.

The Gymnastics Club have been successful Community Chest recipients in 2015 - New Balance Beam and 2017 - the purchase of a horizontal bar, access platform and hoist away rings.

The applicant has indicated they will support the project with \$15,926 cash.

10. Avon Community Services Inc

Avon Community Services is seeking \$2,500 cash in advance to assist with the costs to purchase miscellaneous car parts to deliver an Essential Skills program at the Youth Centre. The proposed program will run over eight weeks and will demonstrate essential skills such as basic car maintenance; checking oils and water; changing a tyre, sewing and basic plumbing.

The applicant has indicated they will contribute \$1,000 in-kind (labour and administration) to the project.

11. Rotary Club of Narrogin Inc

The Rotary Club of Narrogin is seeking \$5,000 cash in advance to assist with the cost of engaging a qualified contractor to apply reflective house numbers on the kerbs. The idea was initiated by volunteers of Narrogin's St John Ambulance citing that many house numbers do not match up with GPS maps, or where numbers are not visible in the dark.

The total project cost is estimated at \$30,000, the applicant has indicated some in-kind support may be required from the Shire to provide accurate house numbers for the 2,297 houses in Narrogin. They will also seek funding from All West Australians Reducing Emergencies (AWARE) and Lotterywest.

12. Narrogin Primary School P&C Inc

The Narrogin Primary School P&C is seeking \$5,000 cash in advance towards the cost to deliver the Narrogin Voice Festival. The granted funds will go towards the cost to hire light and sound equipment.

The total project is estimated to cost \$21,148, the applicant has indicated they will contribute \$2,300 cash, \$3,350 in-kind and a cash contribution by the Narrogin Primary School of \$7,998.

13. Narrogin Agricultural Society Inc

The Narrogin Agricultural Society is requesting \$4,000 cash in advance to help cover the costs to deliver a free community event which will acknowledge the opening of the Community Open Space, which is located on the old outdoor swimming pool site at the Narrogin Regional Leisure Centre. The total project cost is estimated at \$4,700.

The event will include giant inflatables, water games in the indoor pool, and a family movie on a blow up movie screen.

The applicant has indicated they will support the event with a cash contribution of \$500 and in-kind support (volunteer labour) of \$1,050. The Shire is requested to pay to the YMCA venue hire fees.

14. Narrogin Eagles Sporting Club Inc

The Narrogin Eagles Sporting Club is seeking \$4,840 cash in advance for the cost of materials and fabrication of the proposed shade structure.

They were recipients in the 2019/2020 Community Chest with an approved grant of \$2,000 to purchase materials to construct a shade structure. Due to COVID restrictions, the project was unable to be completed by 30 June 2020.

The applicant indicated they will support the project with \$1,000 in-kind (volunteer labour) to install the structure.

The members of the Reference Group did not support this application, citing that the applicant received approval for a \$2,000 grant for the same project from March 2020 Community Chest. The amount of \$2,000 for the approved unacquitted grant was requested to be carried over to financial year 2020/2021. Refer to Recommendation 7 of 7 for the Reference Group's recommendation.

15. Narrogin Blue Light Unit

The Narrogin Blue Light Unit is seeking \$5,000 cash in advance to help cover the cost of delivering the popular Back to School event in late January 2021.

The applicant has indicated they will support the project with \$2,500 in-kind (volunteer labour) and donations of \$250. The money will be used to pay for equipment hire, advertising and catering at the event.

This is the second year this event has been coordinated. The Administration suggests that this event could be supported with a cash contribution from the 2020/2021 Festivals and Events Budget GL2110821.

16. West Coast Jet Sprint Club Inc

The Jet Sprint Club is seeking \$5,000 to cover costs associated with coordinating a jet boat racing event. The Jet Sprint Club is proposing to reactivate the former jet boat racing space, also known as Archibald Park with a free community event, the date is yet to be advised.

It is approximately 17 years since the last jet boat racing event was last held in Narrogin. The Administration suggests that this event could be supported with a cash contribution from the 2020/2021 Festivals and Events Budget GL2110821.

17. The Salvation Army Narrogin Corps

The Salvation Army Narrogin Corps is seeking \$5,000 cash in advance to assist with the cost of purchasing and installing suitable shop fittings for their proposed new shop located at 58 Federal Street. The total project cost is estimated at \$15,551.85.

The Salvos are planning to relocate their Thrift Shop from the premises currently located on Doney Street, opposite the New Cornwall Hotel to 58 Federal Street. The proposed move will incorporate some rebranding of the business model to make it a more appealing retail layout. The money raised from the Thrift Shop funds other community programs delivered by the Salvation Army.

The applicant has indicated they will support the project with a cash contribution of \$10,551.85.

It should be noted that the Council does not normally support religious organisations with contributions or donations towards activities, for this reason the project, whilst meritorious has not been supported.

The Administration acknowledges that the Shire of Narrogin does support annually, the Carols by Candlelight event each year noting that this event is reported to have originated in Australia in 1938 and is considered by the community to be an Australian tradition.

The Reference Group did not support the application and recommended the Community Chest Guidelines be amended to reflect that applications from religious organisations are not eligible. Details are in Recommendation 4 of 7.

Consultation

Consultation has been undertaken with the:

- Community Chest Grants Reference Group
- Chief Executive Officer
- Community Chest Applicants

The grants were advertised in July and August 2020 closing on 31 August in the Narrogin Observer, the Shire's Facebook page and via direct communication to community and sporting groups.

Statutory Environment

Narrogin Eagles Sporting Club and the Highbury District Community Council will require planning approval before commencing construction, if approved.

Narrogin Croquet Club will require approval from the Environmental Health Officer before proceeding with the kitchen upgrade, if approved.

Narrogin Blue Light Unit, Narrogin Agricultural Society, West Coast Jet Sprint Club and Narrogin Primary School P&C will be required to submit an Outdoor Event Approval Application, if supported.

Policy Implications

Nil

Financial Implications

After deducting \$15,250 from the \$100,000 allocated in the 2020/2021 Budget, there remains a balance of \$84,750 for Round 1 and Round 2 applications.

The total value of Council's contributions recommended are as follows:

From the Community Chest Fund:

\$39,310.83.

From the Festivals and Events Budget:

\$14,000.00.

Strategic Implications

Shire of Narrogin Strategic Community Plan 2017-2027		
Objective	1.	Economic Objective (Support growth and progress, locally and regionally)
Outcome:	1.1	Growth in revenue opportunities
Strategy:	1.1.2	Promote Narrogin and the Region
Outcome:	1.2	Increased Tourism
Strategy:	1.2.1	Promote, develop tourism and maintain local attractions
Objective	2.	Social Objective (To provide community facilities and promote social interaction)
Outcome:	2.1	Provision of youth services
Outcome:	2.2	Build a healthier and safer community
Strategy:	2.2.1	Support the provision of community security services and facilities
Strategy:	2.2.2	Advocate for mental health and social support services
Outcome:	2.3	Existing strong community spirit and pride is fostered, promoted and encouraged
Strategy:	2.3.2	Engage and support community groups and volunteers
Strategy:	2.3.3	Facilitate and support community events
Strategy:	2.3.4	Provide improved community facilities (eg library/recreation)
Strategy:	2.3.5	Encourage and support continued development of arts and culture
Outcome:	2.4	Cultural and heritage diversity is recognised
Strategy:	2.4.2	Support our Narrogin cultural and indigenous community

Voting Requirements

Simple Majority

See over

OFFICERS' AND REFERENCE GROUP RECOMMENDATION 1 OF 7

That, with respect to the Community Chest Grant applications received, the Council approve the following applications, subject to the listed conditions:

1. Narrogin's Menshed Inc for \$3,849 towards the purchase of a new fridge and a vehicle hoist;
2. Narrogin Cottage Homes Inc for \$5,000 to provide governance training for the nine volunteer board members;
3. Narrogin Croquet Club Inc for \$2,248 towards the continued upgrade of the clubroom kitchen. The Applicant will obtain relevant approvals for the proposed upgrade from the Shire's Environmental Health Officer;
4. Highbury District Community Council Inc for \$4,213.83 to pay the costs associated with upgrading the toilets located at the Highbury Hall. The Applicant will obtain a Building Approval before commencing work;
5. Narrogin RevHeads for \$2,500 for the purchase of marquees.

Conditions:

- a. The Applicants are to complete the project and acquit the grant by 30 June 2021 in accordance with the submitted application, and present copies of paid invoices and receipts related to the costs associated with the project, together with a tax invoice made out to the Shire up to the maximum amount of the approved grant, (plus GST if applicable) and submit together with copies of promotional material relating to the project, and photos of the completed project; and
- b. Upon satisfying condition (a) above, the Shire will reimburse up to the approved amount.

OFFICERS' AND REFERENCE GROUP RECOMMENDATION 2 OF 7

That, with respect to the Community Chest Grant applications seeking cash in advance, the Council approve the following applications, subject to the listed conditions:

1. Narrogin Gymnastics Club Inc for \$5,000 towards the cost of purchasing safety flooring for the gym at the Railway Institute Building;
2. Avon Community Services Inc for \$2,500 to purchase car parts for the Essential Skills program for youth;
3. Rotary Club of Narrogin, for \$5,000 to appoint a qualified contractor to paint reflective numbers on kerbs as an emergency services initiative;
4. Narrogin Primary School P&C Inc for \$5,000 to assist with the cost to deliver the inaugural Narrogin Voice Festival;
5. Narrogin Agricultural Society Inc for \$4,000 to assist with the costs associated with the community event at the Narrogin Regional Leisure Centre.

Conditions:

- a. The Applicants are to provide the Administration a copy of the quote for the costs in accordance with the proposed project, together with a tax invoice made out to the Shire for the amount of the approved grant (plus GST if applicable); and
- b. Upon satisfying condition (a) above, the Shire will pay in advance up to the approved granted funds; and
- c. The Applicant is to acquit the grant by 30 June 2021 and present copies of paid invoices and receipts related to the cost to complete the project in accordance with their application, and submit to the Administration together with copies of advertising and promotional material, social media posts and photographs of the completed project, noting that if the amount paid is greater than the amount expended, the organisation will refund the difference to the Shire of Narrogin.

OFFICERS' AND REFERENCE GROUP RECOMMENDATION 3 OF 7

That, with respect to the Community Chest Grant applications from Narrogin Blue Light Unit, West Coast Jet Sprint Club and the Narrogin Golf Club, the Council approve the:

1. Narrogin Blue Light Unit event with a cash contribution of \$5,000 from the Shire's 2020/2021 Festivals and Events Budget GL2110821, and to consider an amount of \$5,000 in the 2021/2022 Draft Budget towards sponsoring the event to be ongoing in the Shire's annual calendar of sponsored events.
2. West Coast Jet Sprint Club Inc event with an inaugural cash seed sponsorship of \$5,000 from the Shire's 2020/2021 Festivals and Events Budget GL2110821, and that Council consider an amount of \$5,000 in the 2021/2022 Draft Budget towards sponsoring the event to be ongoing in the Shire's annual calendar of sponsored events. The Council sponsorship will be limited to cash or in-kind services agreed to by the Chief Executive Officer and either in-kind by the Shire of Narrogin or payments direct to local community organisations or marketing and promotions.
3. Narrogin Golf Club Inc for \$4,000 from the Shire's 2020/2021 Festivals and Events Budget GL2110821 as a one off sponsorship contribution for the State Sands Green event in 2021.

OFFICERS' AND REFERENCE GROUP RECOMMENDATION 4 OF 7

That, with respect to the Community Chest Grant application from The Salvation Army Narrogin Corps, for \$5,000 to assist with the cost to purchase and install shop fittings, the application is not supported by Council and that the Guidelines for eligible community groups be amended to exclude religious organisations.

OFFICERS' AND REFERENCE GROUP RECOMMENDATION 5 OF 7

That, with respect to the Community Chest Grant application from the Upper Great Southern Hockey Association Inc for \$2,400 to host a Fixtured Hockey Round on the weekend of 10-12 September 2020, the Council:

1. Recommend that the application is not supported due to the event already being undertaken; and
2. Note that the event is being sponsored for the amount of \$2,000 via existing Budget GL 2110828.

OFFICERS' AND REFERENCE GROUP RECOMMENDATION 6 OF 7

That, with respect to the Community Chest Grant application from the Highbury District Tennis Club Inc to for \$4,427.50 to purchase and install a Bird's Nest Swing in the playground at Highbury Hall, the Council consider the request as part of the 2020/2021 Budget Review.

OFFICERS' AND REFERENCE GROUP RECOMMENDATION 7 OF 7

That, with respect to the Community Chest Grant application from the Eagles Sporting Club Inc for \$4,480 to purchase and install a shade structure, the Council not support the application due to the applicant receiving approval for the same project valued at \$2,000 in the Community Chest Grants round in March 2020, and noting that this amount was carried over to the 2020/2021 Budget.

15.1.1

IFM 2021212

COMMUNITY CHEST APPLICATION FORM (FDRS010)



89 Earl Street
PO Box 1145
Narrogin WA 6312

(08) 9890 0900

www.narrogin.wa.gov.au
enquiries@narrogin.wa.gov.au

CASHIER HOURS:
8:30am – 4:30pm
MONDAY- FRIDAY

The Shire of Narrogin provides funding assistance through the biannual Community Chest funding program to eligible community organisations for events or projects which benefit the Narrogin community. To support the recovery of community groups following the COVID crisis, and for the financial year 2020/2021 cash and in-kind support is available up to a maximum of \$5,000. To further support the recovery process, successful applicants from 2019/2020 and 2018/2019 are eligible and invited to apply.

1. APPLICANT DETAILS

Name of Organisation

MENSHEP NARROGIN INC.

Postal Address

PO BOX 525 NARROGIN WA 6312

Contact Person

FRANK HEFFERNAN

Position

TREASURER

Phone

[REDACTED]

Email

[REDACTED]

Organisation's ABN

26 750 606 735

Is your organisation registered for GST?

Choose an item.

NO

Please attach a copy of your organisations Certificate of Incorporation

Choose an item.

2. PROJECT DETAILS

What is the name of your proposed project or event?

REPLACEMENT OF REFRIGERATOR

Please provide a brief description of project / event (maximum of 100 words)

Our old fridge needs new door seals and is costing us a fortune in power charges. We use it at least twice a week for Morning Teas and also meat for BBR etc.

How will your project / event benefit the Narrogin community?

Our shed is a welcoming place for all men to come for fellowship and share quality time with other men

Estimated project start date

Click here to enter a date. 1 - 9 - 2020

Estimated project completion date

Click here to enter a date. 30 - 9 - 2020

3. ADVERTISING AND PROMOTION

It is a requirement of funding approval that the words "Sponsored by the Shire of Narrogin" and the Shire's logo be displayed at /on your project/event.

Please check the boxes below to indicate the ways you will be able to acknowledge Shire of Narrogin sponsorship:

- Facebook, Instagram, or Twitter posts – please share with, and tag Shire of Narrogin page;
- Display Shire of Narrogin Logo: on your website and posters, in newspaper advertisements, on event signage, programs and flyers;
- Display the Shire of Narrogin flag or banner at your event if possible. (Available upon request)
- Affix Community Chest sign on project (available on request)
- Verbal announcements at event

4. PREVIOUS COMMUNITY CHEST FUNDING

Has your organisation previously received Community Chest funding?

Choose an item.

NO

If yes, please tell us what year, and describe the project and the amount of Community Chest funds received:

5. PROJECT BUDGET

Are you applying for cash or in-kind support, or both (up to a combined maximum of \$2,500)?

Choose an item.

CASH FOR \$1029.00

If you are requesting an in-kind contribution, please provide details below:

Please tell us how the Community Chest funds will be used?

Replace current refrigerator

If you are requesting cash, do you require the Community Chest funds prior to your proposed event / activity?

Choose an item.

~~YES~~ NO

In-kind contributions:

Please calculate and list below the value of any in-kind contributions and include in the Total Project Budget; (e.g. volunteer or donated labour.)

Volunteer and donated labour is calculated at \$25 per hour per person

Contributions	Estimated value \$
Transport (Delivery 2+ volunteers & ute @ \$25 p/h x 1hr	50.00

Project Income and Expenditure

INCOME		EXPENDITURE (please attach quotes)	
**Amount of Community Chest Funds requested in cash	\$1049	Materials Purchase fudge	\$1049
**Amount of Community Chest funds requested in-kind (e.g. Town Hall hire fee waived if applicable /required).	\$	Hire of equipment:	\$
Applicant's cash contribution	\$	Venue hire	\$
In-kind (volunteer, donated labour) transport (delivery)	\$5000	Labour/contractor costs	\$
Sponsorship	\$	Advertising	\$
Donations (cash/materials from others-please list)	\$	Catering costs	\$
Other grants	\$	Entertainment	\$
Sales (stall fees, event tickets/food/merchandise)	\$	Office/administration	\$
Other income (please list)	\$	Other expenditure (please list) In-kind labour (transport)	\$50
TOTAL *INCOME	\$1099	TOTAL *EXPENDITURE	1099

*Income and *Expenditure amounts must be equal

**The total combined Community Chest cash and in-kind request cannot be greater than \$2,500.

Declaration

I declare that I am authorised to prepare and submit this application, and that the information presented is correct to the best of my knowledge.

Name of President or Vice President

ALAN PARKS.

Signature of President or Vice President

Alan Parks.

Date

13th September 2020



Narrogin Betta Home Living
 Phone: 08 9881 3455
 Email: narrogin@my.betta.com.au
 Website: http://www.betta.com.au

\$1049

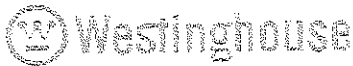

Refrigeration / Top Freezer

Model No: **WTB4600WB-R**

460 L Top Mount Refrigerator

Features

- 341L/119L Fridge/freezer capacity
- Flat Door Design
- Pocket Handles
- Full-width humidity controlled crisper bin
- Spillsafe™ glass shelves
- FamilySafe™ lockable compartment
- Twist Ice & Serve Dispenser
- LED lighting
- Blue feature lighting
- Multi-flow air delivery system
- Frost free
- More environmentally friendly refrigerant (R600a)
- Internal electronic controls
- Quick chill function
- Temperature sensor
- Door alarm
- Service mode with diagnostics feature
- Egg tray
- Adjustable front rollers
- Rear rollers
- Hidden hinges

PRODUCT PROFILE

- Refrigerator Type: Top mount
- Exterior door finish: White
- Handle design: Integrated
- Fridge door opening: Right

	Width	Height	Depth	Weight
	699	1725	723	
Cabinet	693	1718	641	
Door open 90°			1360	

*Use dimensions as a guide only

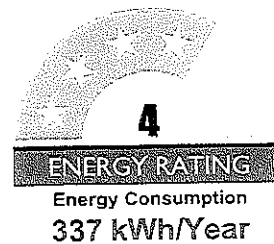

Warranty
 2 Year Domestic Warranty

- Cooling system: Frost free
- Refrigerant: R600a
- Compressor: Inverter
- Food compartment capacity (gross in litres): 341
- Total Gross Capacity (L): 460
- Food compartment capacity (net in litres): 329



Department of Consumer & Employment Protection
Government of Western Australia

WESTERN AUSTRALIA
Associations Incorporation Act 1987
(Section 9(1))

Registered No: A1013952A

Certificate of Incorporation

This is to certify that

MENSHEDS NARROGIN INCORPORATED

was on the twenty-second day of October 2008
incorporated under the
Associations Incorporation Act 1987.

Dated this twenty-second day of October 2008

Commissioner for Consumer Protection

COMMUNITY CHEST APPLICATION FORM (FDRS010)



Shire of
Narrogin
Love the life

89 Earl Street
PO Box 1145
Narrogin WA 6312

(08) 9890 0900

www.narrogin.wa.gov.au
enquiries@narrogin.wa.gov.au

CASHIER HOURS:
8:30am – 4:30pm
MONDAY- FRIDAY

The Shire of Narrogin provides funding assistance through the biannual Community Chest funding program to eligible community organisations for events or projects which benefit the Narrogin community. To support the recovery of community groups following the COVID crisis, and for the financial year 2020/2021 cash and in-kind support is available up to a maximum of \$5,000. To further support the recovery process, successful applicants from 2019/2020 and 2018/2019 are eligible and invited to apply.

1. APPLICANT DETAILS

Name of Organisation

MENSHEDES NARROGIN INCORPORATED.

Postal Address

P.O. BOX 525 NARROGIN 6312

Contact Person

THOMAS O'REILLY

Position

VICE CHAIRMAN

Phone

MENSHEDES NARROGIN@IINET.NET.AU.

Organisation's ABN

26750606735

Is your organisation registered for GST?

Yes

No

Please attach a copy of your organisations Certificate of Incorporation

Yes

No

2. PROJECT DETAILS

What is the name of your proposed project or event?

MENSHEDS NARROGIN CAR HOIST.

Please provide a brief description of project / event (maximum of 100 words)

TO PURCHASE AND INSTALL AN AUTOLIFT
AL-6254 TWO POST CAR HOIST IN THE
CENTRE BAY OF OUR SPECIAL PURPOSE
SHED.

How will your project / event benefit the Narrogin community?

BY ENHANCING THE ABILITY OF MENSHEDS
NARROGIN TO SERVICE A RECENTLY RECOGNISED
NEED FOR A CAR SERVICING FACILITY
FOR MEMBERS AND LIKE MINDED
COMMUNITY MEMBERS

Estimated project start date

Estimated project completion date

1-10-2020

1-2-2021

3. ADVERTISING AND PROMOTION

It is a requirement of funding approval that the words "Sponsored by the Shire of Narrogin" and the Shire's logo be displayed at /on your project/event.

Please tick the boxes below to indicate the ways you will be able to acknowledge Shire of Narrogin sponsorship:

- Facebook, Instagram, or Twitter posts – please share with, and tag Shire of Narrogin page;
- Display Shire of Narrogin Logo: on your website and posters, in newspaper advertisements, on event signage, programs and flyers;
- Display the Shire of Narrogin flag or banner at your event if possible. (Available upon request)
- Affix Community Chest sign on project (available on request)
- Verbal announcements at event

4. PREVIOUS COMMUNITY CHEST FUNDING

Has your organisation previously received Community Chest funding?

Yes	<input checked="" type="radio"/> No
-----	-------------------------------------

If yes, please tell us what year, and describe the project and the amount of Community Chest funds received

4. PROJECT BUDGET

Are you applying for cash or in-kind support, or both (up to a combined maximum of \$2,500)?

CASH

If you are requesting an in-kind contribution, please provide details below:

Please tell us how the Community Chest funds will be used?

TO PURCHASE 1. AUTOLIFT AL-6254
2 POST. 3.8 Tonne FLOOR PLATE
VEHICLE HOIST.

If you are requesting cash, do you require the Community Chest funds prior to your proposed event / activity?

<input checked="" type="checkbox"/> Yes	<input type="checkbox"/> No
---	-----------------------------

In-kind contributions:

Please calculate and list below the value of any in-kind contributions and include in the Total Project Budget; (e.g. volunteer or donated labour.)

Volunteer and donated labour is calculated at \$25 per hour per person

Contributions	Estimated value \$
TO INSTALL AND	
COMMISSION	\$1080
6 x 2 hrs x 25 ⁰ p/hr	
Total In-kind	\$ 1080

Project Income and Expenditure

INCOME		EXPENDITURE (please attach quotes)	
**Amount of Community Chest Funds requested in cash	\$3190	Materials VEHICLE HOIST <i>delivery to Narrogin</i>	\$3190
**Amount of Community Chest funds requested in-kind (e.g. Town Hall hire fee waived if applicable /required).	\$	Hire of equipment:	\$
Applicant's cash contribution	\$	Venue hire	\$
In-kind (volunteer, donated labour)	\$ 1080	Labour/contractor costs	\$ 1080
Sponsorship	\$	Electrician Advertising	\$
Donations (cash/materials from others- please list)	\$	Installer/Installation Catering costs-	\$
Other grants	\$	Entertainment	\$
Sales (stall fees, event tickets/food/merchandise)	\$	Office/administration	\$
Other income (please list)	\$	Other expenditure (please list)	\$
TOTAL *INCOME	\$ 4270	TOTAL *EXPENDITURE	\$ 4270

*Income and *Expenditure amounts must be equal

**The total combined Community Chest cash and in-kind request cannot be greater than \$2,500.



WESTERN AUSTRALIA
Associations Incorporation Act 1987
(Section 9(1))

Registered No: A1013952A

Certificate of Incorporation

This is to certify that

MENSHIEDS NARROGIN INCORPORATED

was on the twenty-second day of October 2008
incorporated under the
Associations Incorporation Act 1987.

Dated this twenty-second day of October 2008

Commissioner for Consumer Protection

NEW now with single sided manual lock release.

Clearfloor 2 post vehicle hoist featuring a lifting capacity of 3800kg. This Australian Standard WorkSafe design registered 2 post clearfloor hoist is designed for the home user, farmer or light mechanical workshop. The clearfloor design is ideal for working with transmission jacks, oil drainers and tool chests as the floor is completely obstruction free. A minimum ceiling height of 3.8m or above is required. The hoist features an easy to operate manual release lock from one side.

GALLERY

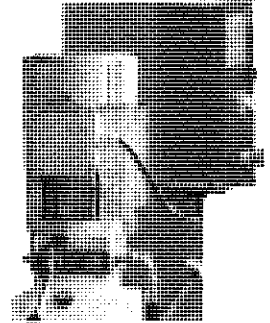
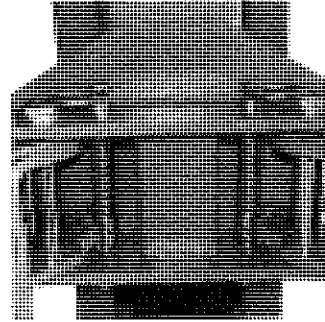
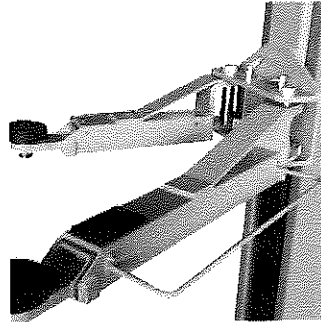

(<https://www.aaq.net.au/>) (<https://www.aaq.net.au/>) (<https://www.aaq.net.au/>) (<https://www.aaq.net.au/>)

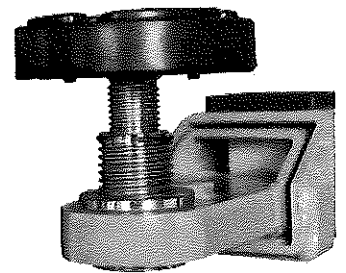
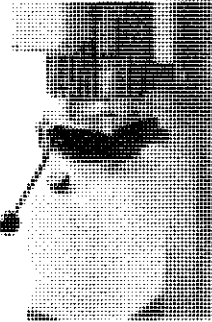
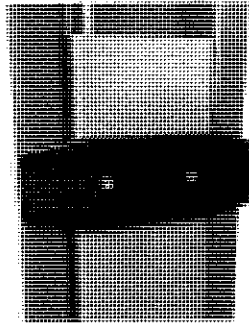
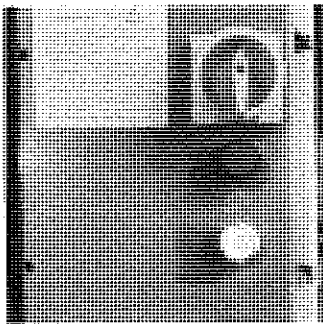

(<https://www.aaq.net.au/>) (<https://www.aaq.net.au/>) (<https://www.aaq.net.au/>) (<https://www.aaq.net.au/>)

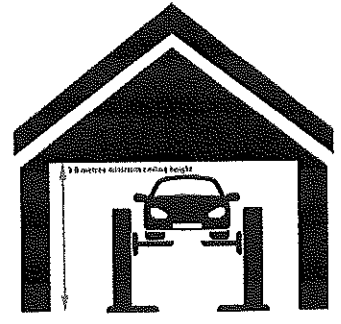
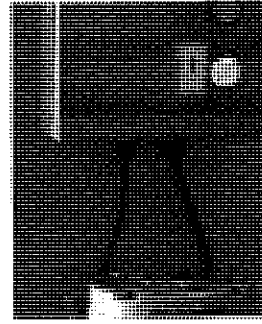
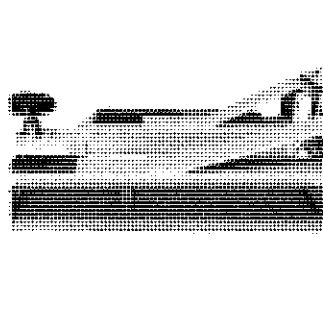
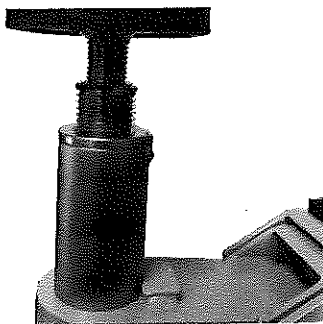

(<https://www.aaq.net.au/>) (<https://www.aaq.net.au/>) (<https://www.aaq.net.au/>) (<https://www.aaq.net.au/>)

Recent Google reviews

In-kind contributions:

Please calculate and list below the value of any in-kind contributions and include in the Total Project Budget; (e.g. volunteer or donated labour.)

Volunteer and donated labour is calculated at \$25 per hour per person

Contributions	Estimated value \$
<i>Total In-kind</i>	\$

Project Income and Expenditure

INCOME		EXPENDITURE (please attach quotes)	
**Amount of Community Chest Funds requested in cash	\$ 2800	Materials VEHICLE HOIST	\$ 2800
**Amount of Community Chest funds requested in-kind (e.g. Town Hall hire fee waived if applicable /required).	\$	Hire of equipment:	\$
Applicant's cash contribution	\$	Venue hire	\$
In-kind (volunteer, donated labour)	\$ 300	Labour/contractor costs 6 x 2 @ \$25	\$ 300
Sponsorship	\$ 660	Advertising ELICTRIC COST	\$ 600
Donations (cash/materials from others- please list)	\$ 990	Catering costs INSTALLATION 7 DELIVERY	\$ 990
Other grants	\$	Entertainment	\$
Sales (stall fees, event tickets/food/merchandise)	\$	Office/administration	\$
Other income (please list)	\$	Other expenditure (please list)	\$
TOTAL *INCOME	\$ 4750	TOTAL *EXPENDITURE	\$ 4750

*Income and *Expenditure amounts must be equal

**The total combined Community Chest cash and in-kind request cannot be greater than \$2,500.

O'Rourke Electric Services

Quote to run a single phase 15amp
circuit to new car hoist at the
Narrogin mens shed

Total - \$660.00 including GST

Todd O'Rourke



19/8/20

Declaration

I declare that I am authorised to prepare and submit this application, and that the information presented is correct to the best of my knowledge

Name of President or Vice President

ALAN PARKS.

Signature of President or Vice President

Alan Parks.

Date

17th August 2020

John D McDougall

From: Patrick Coffey | Advance AutoQuip <sales@aaq.net.au>
Sent: Thursday, 13 August 2020 10:26 AM
To: johnnymack@westnet.com.au
Subject: RE: New enquiry from website
Attachments: John D McDougall - Mensheds Narrogin.pdf

Hi John

Thanks for our enquiry, apologies for the delay with your quote.

We have supplied our hoists to various men's sheds around Perth and WA. Please see our quotation attached.

We have the hoist in stock, ready for despatch.

If the price to Narrogin is a little high, please let me know and I can see if I can contact some other carriers to get a better price.

Kind regards
 Patrick Coffey



Advance AutoQuip

2 McDonald Crescent | Bassendean WA 6054

P. (08) 9279 1663 : W. www.aaq.net.au

Hoists, Lifts & Car Stackers · Tyre Changers · Wheel Balancers · Brake Lathes · All types of Workshop Equipment



From: Advance AutoQuip <sales@aaq.net.au>
Sent: Wednesday, 12 August 2020 5:01 PM
To: Patrick Coffey | Advance AutoQuip <sales@aaq.net.au>
Subject: New enquiry from website

You have received a new enquiry.

Order id	882
Customer name	Mensheds Narrogin - John D McDougall
Email	johnnymack@westnet.com.au
Phone	0427 856 864
Offer	0.00
Comments	Require ASAP a firm quote on the above - delivered to Narrogin Western Australia. For verification for a grant application. Time-frame - Yesterday please Someone forgot to get a quote...

Product name	Price	Quantity	Total
AutoLift 6254A - Baseplate 2 post vehicle hoist	\$2,800.00	1	\$2,800.00



Ref:PC/MN13820
E & O.E

Thursday, 13 August 2020

Attention: John D McDougall
Mensheds Narrogin
0427 856 864
johnnymack@westnet.com.au

QUOTATION ONLY

Thank you for your enquiry, Advance AutoQuip are pleased to quote the following equipment:

Supply one "AutoLift AL-6254" two post, 3.8 tonne floorplate vehicle hoist with single sided lock release **\$2,800.00**

Features:

- Single sided lock release
- Australian Standards design approved
- Complete with bonus 4WD height adaptors and tool trays
- Designed for car storage – first lock is 1100mm high

Technical Specifications:

- Lifting capacity: 3800Kg
- Lifting height: 90-2000mm
- Pad height: 4"
- Post height: 2824mm
- Overall width: 3436mm
- Distance between posts: 2850mm
- Power: 240V/50Hz single phase
- Available: Ex Stock

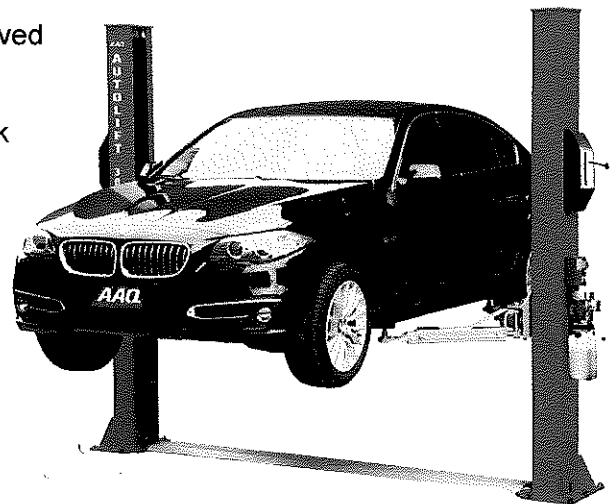

Freight to Narrogin WA – either door to door with a forklift onsite or customer collection from your closest freight depot **\$350.00**

This quotation is valid for 30 days from date of quote and is subject to the below terms and conditions:

Inclusions

- The above prices are **inclusive of GST**.

Exclusions

- Installation of the equipment.
- Shire approvals, earthworks, civil works or any works to the floor, ceiling or walls if the responsibility of the customer.
- The customer is to ensure that their concrete floor is suitable as per the manufacturer's recommendations.
- The above prices do not include dismantling or removal of existing hoist or equipment (other than what is specified in the inclusions).
- The above prices do not include air or electrical connections or disconnections to the equipment; electrical connections must be carried out by a licensed electrician.

Payment is required in full prior to delivery.

All of the above equipment is supplied by a West Australian owned company. Advance AutoQuip has over 35 years' experience as a supplier for the Automotive Industry including the fit out of large workshops such as BMW, Volkswagen, Landrover, Toyota, Holden and Ford.

Please visit our website at www.aaq.net.au for our full range of equipment. If we could be of further assistance to you please do not hesitate to contact me on (08) 9279 1663 or 0407 996 441.

Kindest regards,
Patrick Coffey
Director



AutoLift AL-6254

2 Post Electric Hydraulic Vehicle Hoist
3800 Kg Lifting Capacity
Base Plate Design for Lower Height Ceilings
For Light Mechanical and Home Use

Bonus Inclusions:

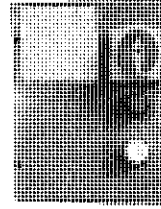

Switch Box
Included

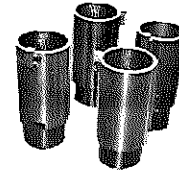

4 x 90mm height adaptors
Included

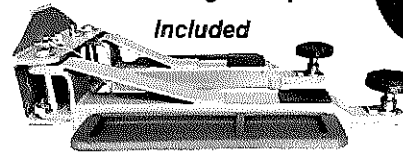

4 x tool trays
Included

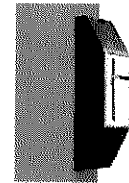

Single Sided
Lock Release
Included



Specification

- Height overall: 3335 mm (inc lock ladders)
- Width overall: 3436 mm
- Lifting height: 90mm-1930mm (with adaptors)
- Lifting capacity: 3800 kg
- Long arm extensions: 890~1390 mm
- Short arm extensions: 740~1150mm
- Power: 240V/50Hz/1Ph (15 Amp)
- Gross weight: 700 kg
- Packing Size: 2850*560*600 mm (hoist)
770*240*340 mm (carton)

Optional Extras:

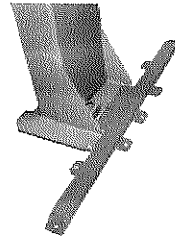

Base Frame
for concrete floor

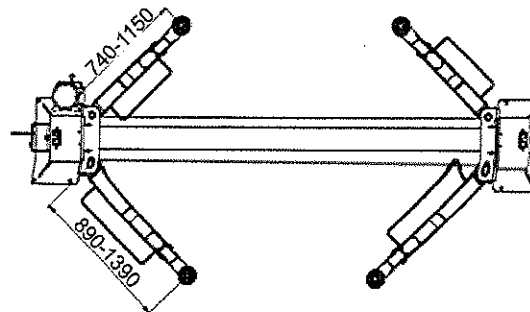
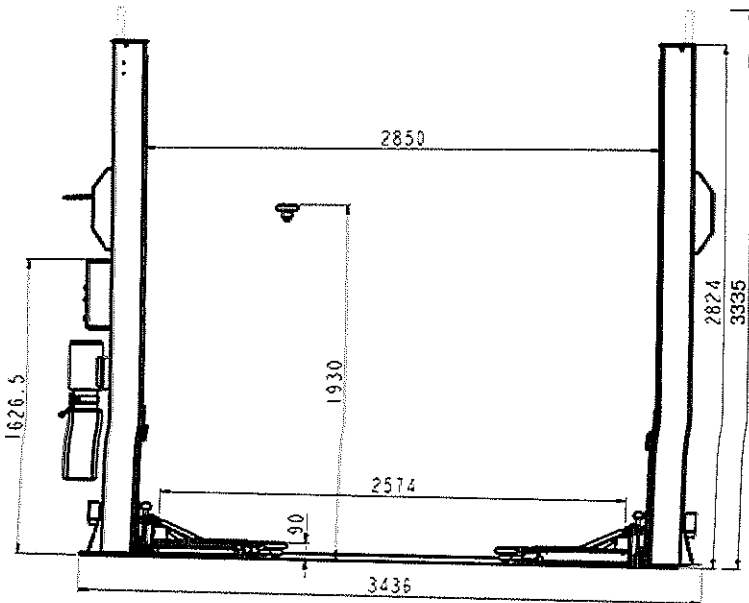

Features

- WorkSafe Design Registered
- Ideal for vehicle maintenance
- High quality powder coated finish
- 24V low voltage controls for safety
- Professional quality power unit
- Safety shut off valve
- Two stage asymmetric telescopic arms
- Two stage screw adjustable pads
- Rubber door protectors
- Single sided manual lock release
- Top limit switch cut-off

COMMUNITY CHEST APPLICATION FORM (FDRS010)



89 Earl Street
PO Box 1145
Narrogin WA 6312

(08) 9890 0900

www.narrogin.wa.gov.au
enquiries@narrogin.wa.gov.au

CASHIER HOURS:
8:30am – 4:30pm
MONDAY- FRIDAY

The Shire of Narrogin provides funding assistance through the biannual Community Chest funding program to eligible community organisations for events or projects which benefit the Narrogin community. To support the recovery of community groups following the COVID crisis, and for the financial year 2020/2021 cash and in-kind support is available up to a maximum of \$5,000. To further support the recovery process, successful applicants from 2019/2020 and 2018/2019 are eligible and invited to apply.

1. APPLICANT DETAILS

Name of Organisation

Narrogin Cottage Homes Inc

Postal Address

50 Felspar Street Narrogin

Contact Person

Sharon Bryce

Position

CEO

Phone

[REDACTED]

Email

ceo@nch.org.au

Organisation's ABN

[REDACTED]

Is your organisation registered for GST?

Yes

Please attach a copy of your organisations Certificate of Incorporation

Choose an item.

2. PROJECT DETAILS

What is the name of your proposed project or event?

Training how to be a successful and effective community board member. (NFP)

Please provide a brief description of project / event (*maximum of 100 words*)

- detailed knowledge of the roles and activities of a board of directors or management committee
- Give a full understanding of the challenges faced in achieving good governance practice in the NFP sector
- strategies for implementing governance within the organisation.

How will your project / event benefit the Narrogin community?

Narrogin Cottage Homes is a not for profit organisation that provides accommodation under 4 different community programs

- Seniors community housing
- Low income rental accommodation
- RFU
- Residential care (NH) which includes specific dementia care unit.

The board consists of 9 volunteers with varied degrees of knowledge and expertise.

Within the board we also sub committees

- Building & landscape
- Finance
- Risk and Governance

Being the board is responsible for the overall governance, management, and strategic direction of the organization and for delivering accountable corporate performance in accordance with the organization's goals and objectives and community expectations. It is of high importance that board members are given the tools to be able to perform their role effectively.

Estimated project start date October 2020 Estimated project completion date October 2020

Date to be confirmed

Date to be confirmed

3. ADVERTISING AND PROMOTION

It is a requirement of funding approval that the words "*Sponsored by the Shire of Narrogin*" and the Shire's logo be displayed at /on your project/event.
Please check the boxes below to indicate the ways you will be able to acknowledge Shire of Narrogin sponsorship:

- Facebook, Instagram, or Twitter posts – please share with, and tag Shire of Narrogin page;
- Display Shire of Narrogin Logo: on your website and posters, in newspaper advertisements, on event signage, programs and flyers;
- Display the Shire of Narrogin flag or banner at your event if possible. *(Available upon request)*
- Affix Community Chest sign on project *(available on request)*
- Verbal announcements at event

4. PREVIOUS COMMUNITY CHEST FUNDING

Has your organisation previously received Community Chest funding?

Choose an item.

If yes, please tell us what year, and describe the project and the amount of Community Chest funds received:

5. PROJECT BUDGET

Are you applying for cash or in-kind support, or both *(up to a combined maximum of \$2,500)*?

Choose an item.

If you are requesting an in-kind contribution, please provide details below:

Not applicable.

--

Please tell us how the Community Chest funds will be used?

<p>This informative course This will provides us with:</p> <ul style="list-style-type: none"> ➤ a sound knowledge of the core duties and legal responsibilities that apply to Board members in the NFP sector and the issues that affect them.

If you are requesting cash, do you require the Community Chest funds prior to your proposed event / activity?

No

In-kind contributions:

Please calculate and list below the value of any in-kind contributions and include in the Total Project Budget; (e.g. volunteer or donated labour.)

Volunteer and donated labour is calculated at \$25 per hour per person

<i>Contributions</i>	<i>Estimated value \$</i>

Project Income and Expenditure

INCOME		EXPENDITURE <i>(please attach quotes)</i>	
**Amount of Community Chest Funds requested in cash	\$5,000	Materials	\$
**Amount of Community Chest funds requested in-kind <i>(e.g. Town Hall hire fee waived if applicable /required).</i>	\$Nil	Hire of equipment:	\$ Nil
Applicant's cash contribution	\$ 850	Venue hire	\$ Nil
In-kind <i>(volunteer, donated labour)</i>	\$ Nil	Labour/contractor costs	\$5700
Sponsorship	\$ Nil	Advertising	\$ Nil
Donations <i>(cash/materials from others-please list)</i>	\$	Catering costs	\$ 150.00
Other grants	\$ Nil	Entertainment	\$ Nil
Sales <i>(stall fees, event tickets/food/merchandise)</i>	\$ Nil	Office/administration	\$ Nil
Other income <i>(please list)</i>	\$	Other expenditure <i>(please list)</i>	\$ Nil
TOTAL *INCOME	\$5,850	TOTAL *EXPENDITURE	\$5,850

**Income and *Expenditure amounts must be equal*

***The total combined Community Chest cash and in-kind request cannot be greater than \$2,500.*

Declaration

I declare that I am authorised to prepare and submit this application, and that the information presented is correct to the best of my knowledge.

SHARON BRYCE
Name of President or Vice President CEO

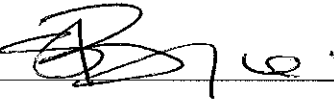

Signature of President or Vice President

Date

18.8.2020

Western Australia



Certificate of Incorporation

Associations Incorporation Act, 1895-~~1953~~ 1957.
Section 3 (3)

These are to Certify that

..

..

..

NARROGIN COTTAGE HOMES

..

has this day been incorporated as an Association under the provisions of
the Associations Incorporation Act, 1895-~~1953~~ 1957.

Dated this twentysecond day of August, 19 62.

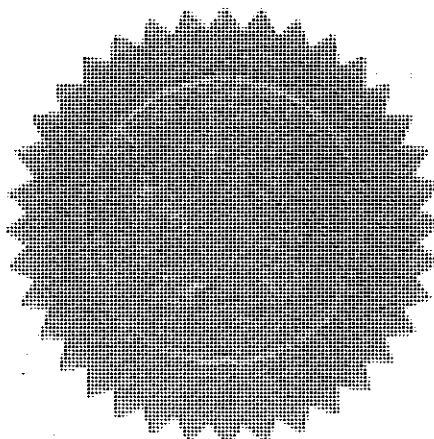

Jhaufolase
REGISTRAR OF COMPANIES.

30444/10/59-1m

NARROGIN CROQUET CLUB (Inc.)

P.O. Box 248
Narrogin 6312
22nd August 2020

Dale Stewart
C.E.O.
Shire of Narrogin
Community Chest Application
89 Earl St
PO Box 1145
Narrogin 6312

Attention: - Loriann Bell

Regarding Community Chest Application.

Please find enclosed an application for the Community Chest Fund in line with the COVID crisis supporting the recovery process for our community.

Narrogin Croquet Club is an inclusive and expanding club. Our youngest member is 36 years old and our oldest member is 89 years old and any age group in between.

Each year we hold a tournament named "Guns 'n' Roses" in April. Due to the COVID 19 crisis this was cancelled this year. However, we have been allocated April 9th 10th and 11th 2021 to hold the "Guns 'n' Roses" tournament again next year. This tournament is organised to have an experienced low handicapper to partner a less experienced player to mentor them and encourage new skills. This tournament attracts experienced players from the metropolitan area, Bunbury, Busselton, Albany, Katanning and other country areas. Most of our visitors stay at B 'n' B's or motels and a few are billeted. Usually 24 – 30 visitors to Narrogin and are always welcome. We have a diner in the evening, usually catering for 60 people or more taking in family that do not play croquet but join in.

As we did not have our usual "Guns 'n' Roses" tournament this year, we are hosting a visitors' day on September 26th between Katanning and Beverley – same format, experienced player with a less experienced player. Expecting around 12 visitors from Katanning and Beverley.

This year we have 5 new members taking our membership up to 39 financial members. Our newest member is a "fly in fly out" man on a 4-week swing and comes and joins in each day we play croquet. Two other people who have joined are teachers who joined in the "Corporate Croquet," enjoyed it and became full time members. Another lady, new to town came along when Probus had their meeting at our facility, liked the game and became a member. Our other new member has been a local for some time, came along, liked the game and joined up.

The Narrogin Croquet Club was established in November 1924, in November 2024 the Croquet Club will celebrate its centenary, 100 years in Narrogin is an achievement to be proud of. By planning for the future, we are hoping to upgrade our facilities to accommodate visitors to help celebrate this achievement.

The stove in our original club house is small, dated and extremely hard to light the gas oven. Although, we do not cook as such, when we have visiting clubs or holding our Croquet Challenge, we need a decent sized oven to heat up sausage rolls, pizzas etc. At present we heat food up in the oven at the Bowling Club then bring back to the Croquet Club. Not very efficient or food safe and would be more hygienic.

We have a quote from Narrogin Betta Electrics for a suitable sized oven – electric oven and gas hot top, also a quote for a range hood suitable for that stove.

Also, two different quotes to update floor coverings which will make it easier to keep clean. At present it is ½ carpet and ½ lino, would like to make it all lino which is easier to keep clean. The quote from Carpet Court is dated January but I have been back to see if it needs updating but they assure me it stays the same.

The club can cover the cost of installing the oven and range hood as the gas and electricity is already there.

If you require any more information, please contact any one of the committee.

Yours sincerely,

Ellen Sprigg
President

COMMUNITY CHEST APPLICATION FORM (FDR3010)



89 Earl Street
PO Box 1145
Narrogin WA 6312

(08) 9890 0900

www.narrogin.wa.gov.au
enquiries@narrogin.wa.gov.au

CASHIER HOURS:
8:30am – 4:30pm
MONDAY- FRIDAY

The Shire of Narrogin provides funding assistance through the biannual Community Chest funding program to eligible community organisations for events or projects which benefit the Narrogin community. To support the recovery of community groups following the COVID crisis, and for the financial year 2020/2021 cash and in-kind support is available up to a maximum of \$5,000. To further support the recovery process, successful applicants from 2019/2020 and 2018/2019 are eligible and invited to apply.

1. APPLICANT DETAILS

Name of Organisation

NARROGIN CROQUET CLUB (INC.)

Postal Address

P.O. Box 248, NARROGIN

Contact Person

ELLEN SPRIGG

Position

PRESIDENT

Phone

[REDACTED]

Email

ellen.sprigg@westnet.com.au

Organisation's ABN

190 159 55074

Is your organisation registered for GST?

Yes No

Pease attach a copy of your organisations Certificate of Incorporation

Yes No

2. PROJECT DETAILS

What is the name of your proposed project or event?

CENTENARY CELEBRATIONS 1924-2024

Please provide a brief description of project / event (maximum of 100 words)

NARROGIN CROQUET CLUB ARE PLANNING AHEAD FOR OUR 100TH ANNIVERSARY IN NOVEMBER 2024. BY CONTINUING TO IMPROVE OUR FACILITIES IT WILL ENABLE US TO INVITE OTHER CLUBS, PAST AND PRESENT MEMBERS AND COMMUNITY TO JOIN US IN ACKNOWLEDGING AND CELEBRATING OUR 100 YEARS OF CROQUET IN NARROGIN.

How will your project / event benefit the Narrogin community?

OUR CLUB SUPPORTS LOCAL BUSINESS FOR PURCHASES AND LOCAL TRADE PERSONEL FOR ANY INSTALLATIONS AND WORK REQUIRED. BY UPGRADING OUR FACILITIES WE WILL CONTINUE TO HOLD OUR ANNUAL "CORPORATE CROQUET" AND OTHER GROUPS SUCH AS ACCESSIBILITIES, YOUTH GROUPS, PROBUS, ARE ABLE TO USE OUR FACILITIES AND ENCOURAGE NEW MEMBERSHIP.

Estimated project start date

Estimated project completion date

MID OCTOBER 2020

DECEMBER 2020- JANUARY 2021

3. ADVERTISING AND PROMOTION

It is a requirement of funding approval that the words "Sponsored by the Shire of Narrogin" and the Shire's logo be displayed at /on your project/event.

Please tick the boxes below to indicate the ways you will be able to acknowledge Shire of Narrogin sponsorship:

- Facebook, Instagram, or Twitter posts – please share with, and tag Shire of Narrogin page;
- Display Shire of Narrogin Logo: on your website and posters, in newspaper advertisements, on event signage, programs and flyers;
- Display the Shire of Narrogin flag or banner at your event if possible. (Available upon request)
- Affix Community Chest sign on project (available on request)
- Verbal announcements at event

4. PREVIOUS COMMUNITY CHEST FUNDING

Has your organisation previously received Community Chest funding?

Yes No

If yes, please tell us what year, and describe the project and the amount of Community Chest funds received

2017/2018 RETAINING WALL AND FENCE BETWEEN GREENS 1 & 2.
2019/2020 UP GRADE OF KITCHEN AND ORIGINAL CLUB HOUSE WITH
HOT WATER SYSTEM AND PAINTING .

4. PROJECT BUDGET

Are you applying for cash or in-kind support, or both (up to a combined maximum of \$2,500)?

CASH

If you are requesting an in-kind contribution, please provide details below:

Please tell us how the Community Chest funds will be used?

TO UP GRADE CLUB HOUSE WITH NEW STOVE
AND RANGE HOOD
FLOOR COVERINGS

If you are requesting cash, do you require the Community Chest funds prior to your proposed event / activity?

Yes No

In-kind contributions:

Please calculate and list below the value of any in-kind contributions and include in the Total Project Budget; (e.g. volunteer or donated labour.)

Volunteer and donated labour is calculated at \$25 per hour per person

Contributions	Estimated value \$
10 HOURS @ \$30 PER HOUR OF VOLUNTEERING TO EMPTY OUR KITCHEN AND REMOVE OLD CARPET AND LINO AND TAKE AWAY. PUT BACK AFTER.	300
Total In-kind	\$ 300- <i>off</i>

Project Income and Expenditure

INCOME		EXPENDITURE (please attach quotes)	
**Amount of Community Chest Funds requested in cash	\$ 2248	Materials OVEN 1899 RANGE HOOD 699 FLOOR COVERINGS 1650	\$ 4248 <i>\$ 1650</i>
**Amount of Community Chest funds requested in-kind (e.g. Town Hall hire fee waived if applicable /required).	\$	Hire of equipment:	\$
Applicant's cash contribution <i>30% of</i>	\$1700	Venue hire	\$
In-kind (volunteer, donated labour) <i>10 hrs @ \$30 per hour</i>	\$300	Labour/contractor costs	\$
Sponsorship	\$	Advertising	\$
Donations (cash/materials from others- please list)	\$	Catering costs	\$
Other grants	\$	Entertainment	\$
Sales (stall fees, event tickets/food/merchandise)	\$	Office/administration	\$
Other income (please list)	\$	Other expenditure (please list)	\$
TOTAL *INCOME	\$ 4248	TOTAL *EXPENDITURE	\$ 4248

*Income and *Expenditure amounts must be equal

**The total combined Community Chest cash and in-kind request cannot be greater than \$2,500.

Declaration

I declare that I am authorised to prepare and submit this application, and that the information presented is correct to the best of my knowledge

Name of President or Vice President

ELLEN SPRIGG

0417173519

ellen.sprigg@westnet.com.au

Signature of President or Vice President

Esprigg

Date

22ND AUGUST, 2020

VICE PRESIDENT:-

MR PHIL de GAUCHY

0424 454 480

SECRETARY: MRS BARBARA POULTNEY

0428 962 662

TREASURER:- MRS LYN McPHARLIN

0408 815 363

CAPTAIN :- MRS SILL NOTTLE

04 29 055 225



NARROGIN BETTA HOME LIVING Attachment 1

32-36 FORTUNE ST NARROGIN WA 6312
 Email: narrogin@my.betta.com.au
 Ph: 08 9881 3455 Fax: 08 9881 3656
 ABN: 20009453301
 BSB: 016 770 ACC: 41741 5252

Quotation No : 25712000364

Charge To

Deliver To

NARROGIN CROQUET CLUB

NARROGIN CROQUET CLUB

Bus Ph	Home Ph	Fax No	Mobile	Ref No	ABN	Job No	Taken By

Date	Time	Account	Salesperson	Customer Order	Comments	Date Read	Terminal	Page
29-07-20	03:07pm	25700001676	142 Chloe			29-07-20	TILL2	1 of 1

Item Code	Model No	Description	Qty	Unit Price	Total Inc
762618	WFE904SC	WESTINGHOUSE FREESTANDING DUAL FUEL COOKER	1	1899.00	1899.00

Total EX GST :	\$ 1726.36
Total Inc GST (\$172.64):	\$ 1899.00

Whilst risk in the goods shall pass on delivery to the buyer - legal and equitable title shall remain with the vendor until payment in full for all debts accrued or owed to the vendor is made

WE'RE PROUD TO SUPPORT YOUNGCARE

Youngcare is committed to helping young Aussies with high care needs live life with choice.



NARROGIN DELTA HOME LIVING
 32-36 FORTUNE ST NARROGIN WA 6312
 Email: narrogin@my.betta.com.au
 Ph: 08 9881 3455 Fax: 08 9881 3656
 ABN: 20009453301
 BSB: 016 770 ACC: 41741 5252

Quotation No : 25712000366

Charge To

Deliver To

ELLEN SPRIGG

NARROGIN CROQUET CLUB

Bus Ph	Home Ph	Fax No	Mobile	Ref No	ABN	Job No	Taken By

Date	Time	Account	Salesperson	Customer Order	Comments	Date Recd	Terminal	Page
03-08-20	10:38am	25700001676	12 Damian			03-08-20	TILL1	1 of 1

Item Code	Model No	Description	Qty	Unit Price	Total Inc
206	WRC913SB	WESTINGHOUSE RANGEHOOD CANOPY CLEARANCE MODEL	1	495.00	495.00
983	WRC914SC	WESTINGHOUSE CANOPY RANGEHOOD STAINLESS STEEL	1	699.00	699.00

Total EX GST :	\$ 1085.45
Total Inc GST (\$108.55) :	\$ 1194.00

Until risk in the goods shall pass on delivery to the buyer - legal and equitable title shall remain with the vendor until payment in full for all debts accrued or owed to the vendor is made

WE'RE PROUD TO SUPPORT YOUNGCARE

Youngcare is committed to helping young Aussies with high care needs live life with choice.

Narrogin Carpets & Curtains
 139 Federal St Narrogin 6312
 Ph (08) 9881 4959 Fax (08) 9881 1483
 narrogincurtains@bigpond.com
 ABN 99 322 584 077

DREAM IT. STYLE IT. LIVE IT

We are pleased to submit the following quotation for your consideration:-

Price

QUOTATION

Ref: Q10713

Date: 15/01/2020

Croquet Club Narrogin

Phone (H)

Phone (W)

Fax

Mobile

Narrogin WA 6312

Email lynmc@westnet.com.au

Job Ref No

subfloor if needed			\$550.00
Supply and install stock sheet vinyl to clubroom			\$950.00
Please forward remittance advice to narrogincurtains@bigpond.com			
Bank Name	Narrogin Carpets & Curtains	Sub Total:	\$1,500.00
BSB	016770	GST:	\$150.00
Account Number:	109978627	Total Price:	\$1,650.00
<u>Conditions of sale</u>			

TRADING TERMS: PLEASE NOTE:

Payment terms; 50% deposit and balance of account owing payable on receipt of goods/services.

Rental Properties: Payment on order

Purchase Orders: Will be the responsibility of the orderer and payable in full when the job has been completed.

Bookkeeping Fees: \$25.00 per month on accounts over 30 days

Debt recovery: Charges and fees will be incurred and payable by the debtor

Any floor preparation, removal of existing floor coverings or furniture moving will be charged at a rate of \$75 per hour. Any floor preparation materials will be charged accordingly

Personal Effects: Customers responsibility

Rubbish removal: \$20/m³ Asbestos: as per quote

Door cutdowns: As per quote

Ovens/fridges: As per quote

Customers measurements: Customers responsibility

#NOTE: By paying a deposit or ordering materials, I accept these Terms and Conditions of Sale.

We hope the above meets with your requirements and await your decision. Any further queries feel free to contact me anytime.

Yours faithfully

Shane Thornton

Quotation is valid for 14 days then subject to rise and fall. All materials and workmanship are fully guaranteed.

Narrogin Furnishings

ABN 44 463 374 935

83 Federal Street
NARROGIN WA 6312

(08) 9881 2443 admin@ngnfurn.com.au



Quote 00113337

Bill To:

NARROGIN CROQUET CLUB
PO BOX 248
NARROGIN WA 6312

Ship To:

NARROGIN CROQUET CLUB
EARL ST
NARROGIN WA 6312

Ph: 0428962662 BARB

Email: ellensprigg@westnet.com.au

Sales Person	Your Order/Ref. No.	Terms	Date
GREG CLARK	VINYL PLANKS	C.O.D.	1/08/2020

QTY/ UNITS	DESCRIPTION	AMOUNT
32.55	URBANFIT COASTAL BLACKBUTT 436 HEAVY DUTY COMMERCIAL 7MM VINYL PLANKS REMOVAL OF EXISTING CARPET AND VINYL	\$2,200.00

Comment:

QUOTE FOR GRANT

Sale Amount:	\$2,200.00
GST:	\$200.00
Total:	\$2,200.00
Paid Today:	\$0.00

HOW TO PAY:

*Direct Deposit: BSB: 306027 Account: 4623589 Reference: Your invoice number

*Phone the store 08 9881 2443 to pay via credit card - Mastercard or Visa

*Cheque/money order made payable to Narrogin Furnishings

Balance Due:	\$2,200.00
---------------------	-------------------

All goods supplied/installed by Narrogin Furnishings remain the property of Narrogin Furnishings and title shall not pass to the customer until such time as payment is received in full by Narrogin Furnishings. In the event that payment is not received pursuant to the terms of this contract, then Narrogin Furnishings is granted a licence by the customer to enter into the customer's property to retrieve any goods that they have supplied/installed on behalf of the customer. Notwithstanding that the title in goods remains with Narrogin Furnishings, risk in the goods passes to the customer immediately upon the delivery of the goods to the customer.

Narrogin Furnishings

ABN 44 463 374 935

83 Federal Street
NARROGIN WA 6312

(08) 9881 2443 admin@ngnfurn.com.au



Quote 00113407

Bill To:

NARROGIN CROQUET CLUB
PO BOX 248
NARROGIN WA 6312

Ship To:

NARROGIN CROQUET CLUB
EARL ST
NARROGIN WA 6312

Ph: 0428962662 BARB

Email: ellensprigg@westnet.com.au

Sales Person	Your Order/Ref. No.	Terms	Date
GREG CLARK	CROQUET CLUB VINYL	C.O.D.	17/08/2020

QTY/ UNITS	DESCRIPTION	AMOUNT
9.5	PURE OAK 160M TO KITCHEN AREA REMOVAL OF EXISTING CARPET AND VINYL	\$1,100.00

Comment:

QUOTE FOR GRANT

Sale Amount:	\$1,100.00
GST:	\$100.00
Total:	\$1,100.00
Paid Today:	\$0.00

HOW TO PAY:

*Direct Deposit: BSB: 306027 Account: 4623589 Reference: Your invoice number

*Phone the store 08 9881 2443 to pay via credit card - Mastercard or Visa

*Cheque/money order made payable to Narrogin Furnishings

Balance Due: \$1,100.00

All goods supplied/installed by Narrogin Furnishings remain the property of Narrogin Furnishings and title shall not pass to the customer until such time as payment is received in full by Narrogin Furnishings. In the event that payment is not received pursuant to the terms of this contract, then Narrogin Furnishings is granted a licence by the customer to enter into the customer's property to retrieve any goods that they have supplied/installed on behalf of the customer. Notwithstanding that the title in goods remains with Narrogin Furnishings, risk in the goods passes to the customer immediately upon the delivery of the goods to the customer.

PO BOX 908 ALBURY NSW 2640



Australian Government
Australian Business Register

135554/A/049412

NARROGIN CROQUET CLUB INC
BOX 248
NARROGIN WA 6312

Our reference: BRR/CIR
Phone: 13 92 26
Client ID: 19 015 955 074

28 October 2016

*Still current
Aug 2018*

Your Australian business number details are out of date.

Hello,

It seems that some of your Australian business number (ABN) details are out of date. You are legally required to let us know within 28 days if any of your registration details change. To make sure the Australian Business Register is correct, please contact us to update the following details:

- No authorised contact listed

What you need to do

If you need to update your details or you're no longer in business and need to cancel your ABN, you can:

- › access our online services using your AUSkey
- › call us.

Don't write on the extract and return it to us as this will cause delays.

If you still need your ABN and your details are correct and complete, you don't need to do anything. However, as part of a regular review we may contact you in the future to talk about your circumstances and confirm you are still entitled to an ABN.

What you need if you call us

If you call us we need to know we're talking to the right person before we can discuss your ABN information. We'll ask you for details only you, or an authorised person, would know. An authorised person is someone you've told us can share information or make decisions for you. It will help if you quote your ABN, which you can find at the top of this letter.

How your ABN details are used

Your information is used by government agencies to plan and invest in infrastructure that helps support the Australian community. It's also a valuable resource in disaster planning and recovery.

Other businesses and the community also use details on the Australian Business Register to confirm business information. It's a community asset that you play an important role in helping to keep accurate.

Yours faithfully,

John Dardo

Deputy Registrar of the Australian Business Register

UPDATE YOUR DETAILS

To cancel your ABN or update your details you can access our online service at abr.gov.au using your AUSkey. If you don't have an AUSkey, but would like to register for one, go to abr.gov.au/AUSkey

FOR MORE INFORMATION

Call us on **13 92 26** between 8.00am and 6.00pm, Monday to Friday.

COMMUNITY CHEST APPLICATION FORM (FDRS010)



89 Earl Street
PO Box 1145
Narrogin WA 6312

(08) 9890 0900

www.narrogin.wa.gov.au
enquiries@narrogin.wa.gov.au

CASHIER HOURS:
8:30am – 4:30pm
MONDAY- FRIDAY

The Shire of Narrogin provides funding assistance through the biannual Community Chest funding program to eligible community organisations for events or projects which benefit the Narrogin community. To support the recovery of community groups following the COVID crisis, and for the financial year 2020/2021 cash and in-kind support is available up to a maximum of \$5,000. To further support the recovery process, successful applicants from 2019/2020 and 2018/2019 are eligible and invited to apply.

Shire of Narrogin
RECEIVED

31 AUG 2020

15.1.1/IFM2021388.

1. APPLICANT DETAILS

Name of Organisation

HIGHBURY TENNIS CLUB

Postal Address

P.O. BOX 350 NARROGIN. 6312

Contact Person

MRS. YVONNE SCOTT

Position

SECRETARY

Phone

[Redacted]

Email

[Redacted]

Organisation's ABN

13 332 697 889

Is your organisation registered for GST?

Yes No

Please attach a copy of your organisations Certificate of Incorporation

Yes No

remove this top section if desired before framing

MINISTRY OF
FAIR TRADING

WESTERN AUSTRALIA
Associations Incorporation Act 1987
Section (1)



Registered No.: A1006479F

Certificate of Incorporation

This is to certify that

HIGHBURY TENNIS CLUB (INC)

has this day been incorporated under the
Associations Incorporation Act 1987

Dated this twenty-fifth day of September 1997

A handwritten signature in black ink, appearing to be 'J. Smith'.

Assistant Commissioner for Corporate Affairs

CERTIFICATE

Australian Business Register

Australian Business Number(ABN) : **13 332 697 889**

Legal Name : **HIGHBURY TENNIS CLUB INCORPORATED**

Trading Name : **HIGHBURY TENNIS CLUB**

ABN Status : **Registered**

ABN Registration Date : **1 November 1999**

Postal Address : **PO BOX 350
NARROGIN WA 6312**

Business Address : **HIGHBURY
HIGHBURY WA 6312**

Type of Entity : **Incorporated Entity**

Industry Code (ANZSIC) : **Not Available**

Continued ...

2. PROJECT DETAILS

What is the name of your proposed project or event?

Installation of a 'COMMERCIAL GRADE': 'A' FRAME BIRDS NEST SWING for Wilbur Park, Highbury, Shire of Narrogin.

Please provide a brief description of project/event.

The Highbury Tennis Club members currently care-takes, maintains and actively improves the park. The HTC dismantled the old play equipment (from the new Memorial Park) and moved it to its current location, a shared area with HTC and wider Shire community. This move created a three-stage play area: Enclosed toddlers' area, undercover area and enclosed park. With the help of the Shire C/C grants and the HTC members labor and in-kind donations from the wider farming community, we have established the three stage secure play areas, re-fenced park, installed reticulation and grassed area. We request the shire to purchase the new swing and the HTC will install using donated machinery, labor and purchase any other goods needed to complete the task.

How will your project/event benefit the Shire of Narrogin community?

The Highbury Tennis Club working with the Highbury District Community Council have a strategic plan for upgrading and making the Highbury Town site a desirable place for all ages. This small addition will fit the beautification project by providing an inviting play area for families not only in the townsite but those living in the outer areas too. The shady, grassed area with quality equipment will make it an inviting place to visit and picnic. The HTC children and visiting clubs will enjoy this shared area through the summer season of tennis. In addition, this design of swing is sought after, not only for its sturdy structure but for families with children who have limited mobility. It can be stimulating as well as consoling in its movements.

Estimated project start date: October 2020

Estimated project completion date: October 2020

3. ADVERTISING AND PROMOTION

It is a requirement of the funding approval that the words “Sponsored by the Shire of Narrogin” and the Shire’s logo be displayed at/on your project/event.

Please indicate the ways you will be able to acknowledge Shire of Narrogin sponsorship:

- HTC Email, Facebook, SLAM site.
- HDCC/HTC Community Newsletter, which is distributed through letterbox drop has the Shire’s logo and news updates of what has been achieved around the townsite/tennis club and the Shire’s contributions are thanked/acknowledged.
- Highbury Tennis Club Hardcourt tournament flyer.
- Affix Community Chest Sign. PLEASE we request signs for the playground fence as well as Memorial Park.
- Formally Thanked at Seasonal Dinners, Openings and Closings.

4. PREVIOUS COMMUNITY CHEST FUNDING

Has your organization previously received Community Chest funding?

YES: In 2019 (March), the HTC received funding of \$2,500.00 for the Wilbur Park to be fully reticulated by a contractor.

The HTC was committed to preparing the site and its future maintenance.

The HTC: removed old brick paving; leveled and prepared the surface with donated sand and bobcat with volunteer labor; Lay 1m wide brick paving borders around clubhouse walls for the installation of Junction Boxes; provide white sand for play equipment; establish grass through runners and seed suitable for climate conditions; and to continue doing general maintenance work-mowing, weeding, spraying and to continue our improvement plans.

Please see attached photographs showing past and present improvements.

5. PROJECT BUDGET

Are you applying for cash or in-kind support, or both (up to a combined maximum of \$5,000)?

HTC are applying for cash only: PLAYMASTER: A FRAME BIRD'S NEST SWING plus Freight to NGN Shire Depot:

- A FRAME BIRD'S NEST SWING=\$3,875.00 (ex GST) Total= \$4,262.50 (Inc. GST)
- FREIGHT CHARGE to the Shire=\$ 150.00 (ex GST) Total=\$ 165.00 (Inc. GST) of Narrogin Works Depot

(using local company Kirby Freight)

TOTAL: \$4,427.50

1. The Community Chest Funds will be used solely for the purchase of product and freight to Depot: Shire of Narrogin.
2. All installation works: Transport to Highbury, machinery, goods i.e. cement, labor will be the HTC responsibility to incur these costs.

6. If you are requesting cash, do you require the Community Chest funds prior to your proposed event/activity? **NO.**

#####Special Note:

Please look at Page 2 of the attached quote at the asterisked points about **Warranty, Australian Safety Standards and Insurance.**

- 'We offer a 20-year structural guarantee on our playground equipment. Our warranty remains in place even if you decide to install the equipment yourself.'
- 'Insurance- our equipment is fully covered by our Public, Products and Professional Indemnity Insurance regardless of whether the equipment is installed by Playmaster or yourself.'

In-kind contributions:

Please calculate and list below the value of any in-kind contributions and include in the Total Project Budget; (e.g. volunteer or donated labour.)

Volunteer and donated labour is calculated at \$25 per hour per person

<i>Contributions</i>	<i>Estimated value \$</i>
<i>Volunteer Labour to: Pick up goods from NGN Shire DEPOT, to construct play equipment, to dig 4 holes, to install and cement into ground and clean debris from site.</i>	<i>4 adults@ 2hours each @ \$25 an hour = \$200.00</i>
<i>HTC to purchase 8 bags of 'Rapid Set Cement'</i>	<i>8bags @ \$8.60 each=\$68.80</i>
<i>ALL equipment: Bobcat/digger, Utilities, specialist assembly tools and gravel/sand</i>	<i>Donated</i>

Project Income and Expenditure

INCOME		EXPENDITURE (please attach quotes)	
**Amount of Community Chest Funds requested in cash	\$4,427.50	Materials	\$4,427.50
**Amount of Community Chest funds requested in-kind (e.g. Town Hall hire fee waived if applicable /required).	\$	Hire of equipment:	\$Donated
Applicant's cash contribution	\$68.80	Venue hire	\$
In-kind (volunteer, donated labour)	\$200.00	Labour	\$200.00
Sponsorship	\$	Advertising	\$
Donations (cash/materials from others-please list)	\$	Catering costs	\$
Other grants	\$	Entertainment	\$
Sales (stall fees, event tickets/food/merchandise)	\$	Office/administration	\$
Other income (please list)	\$	Other expenditure: cement	\$68.80
TOTAL *INCOME	\$4,696.30	TOTAL *EXPENDITURE	4,696.30

**Income and *Expenditure amounts must be equal*

***The total combined Community Chest cash and in-kind request cannot be greater than \$2,500.*



10 Absolon Street, Palmyra WA 6157
P: (08) 9359 3344
M: 0432 774 960
E: sales@playmaster.com.au
W: www.playmaster.com.au
ABN: 92 615 660 556

Safe, Innovative, Exciting Playground Equipment

18th August 2020

Reference: QN-01

Yvonne Scott
Highbury Tennis Club
C/- wadellafarm@bigpond.com

Dear Yvonne,

Thank you for the opportunity to quote on an A Frame Bird's Nest Swing

I have pleasure in forwarding the supply only (Ex GST) for your consideration.

Supply Only EX GST

- A Frame Bird's Nest Swing

\$3875.00 ex GST

INC. GST
(\$4,262.50)

**Freight Charge to the Shire of Narrogin Works Depot -
(Using Local Narrogin Company Kirby Freight)**

\$150.00 EX GST

(\$165.00)

Thank you for requesting quotations from our 100% Western Australian family owned and run business.

<p>Additional costs to consider for Installation</p> <ul style="list-style-type: none"> • Removal of spoils (onsite or skip bin required?) • Temp Fence (requires 2 site visits) • Service Locations

If you require any further information regarding the above, please do not hesitate in contacting me on (08) 9359 3344 or alternatively on 0432 774 960.

I look forward to hearing your response.

Kind Regards,

Paula Harris
Managing Director
Playmaster Pty Ltd

Important Points when considering a Playmaster playground:

- ✓ Our platforms are made from marine grade aluminium, which is the best heat dispersing metal and completely rust resistant. Our platforms are dimpled to provide a non-slip surface while alleviating the harshness to knees and elbows caused by checker plate patterns.
- ✓ Our uprights which form the main framework of our equipment are manufactured from 75 x 75mm Galvanised (inside and out), Powder Coated Steel. This provides greater strength and a more robust appearance.
- ✓ We use Stainless Steel vandal proof fasteners which cannot be adjusted without a special tool.
- ✓ All of our posts are pre-drilled and inserted in our factory, this enables our equipment to simply bolt together on site.
- ✓ We offer a wide range of colours. All steel components are coated in a lead free baked on powder coat finish of 80-120 microns, which exceeds the required standard of 40 microns.
- ✓ Our equipment is completely modular which means you can extend or modify your playground at any stage.
- * ✓ **Warranty** - We offer a **20 year** structural guarantee on our playground equipment. Our warranty remains in place even if you decide to install the equipment yourself.
- * ✓ **Australian Safety Standards** - Playmaster playground equipment meets all current Australian Safety Standards for Playground Equipment (AS4685.2017: 1-6 & 11).
- * ✓ **Insurance** – Our equipment is fully covered by our Public, Products and Professional Indemnity Insurance regardless of whether the equipment is installed by Playmaster or yourself.

This Quotation does not include:

- Identifying and capping of any reticulation points within the installation area.
- Site security during any product installation period. Playmaster will not be liable for any costs involved to replace or repair any product that may be damaged or stolen due to vandalism during the installation process. Protection of equipment during curing time is the client's responsibility. If vandalism may be an issue please discuss security options with your Playmaster representative.
- Digging or removal of tree roots within the site area. This must be removed by customer prior to installation.
- Should Playmaster Pty Ltd install the unit, in the event that there is hard digging on site, the full price will be passed onto the client.
- Underground facilities such as water pipes, cables, electrical and gas services are the responsibility of the client and whilst every precaution is taken these remain the responsibility of the client to inform us of these services and locations.
- 'Making good' (i.e. replacement of paving bricks etc.) All spoils are to be disposed of onsite unless other arrangements have been made with Playmaster.

- Whilst every endeavour will be made to accommodate specific installation dates, successful installation depends on fine weather and the availability of installation expertise; Playmaster will endeavour to meet your program and reserve the right to program the installation to best suit the product integrity.
- Due to unforeseen circumstances, if we are unable to install the above playground equipment on the agreed day, a minimum call out fee of \$250.00 (ex GST) will apply.
- Payment conditions – 30 days upon completion of installation. The equipment remains the property of Playmaster Pty Ltd until the account is paid in full.
- Overdue accounts – Should Playmaster Pty Ltd have any difficulty in recovering outstanding accounts then we reserve the right to charge interest at the rate of 1.5% per calendar month. We reserve the right to pass your account to a collection agency and add all charges involved in the recovery of overdue accounts to the original account.
- Quote Validity – This quote is valid 90 Days from today's date.

*(18th August)
2020*

playmaster
Pty. Ltd.
Safe, Innovative, Exciting Playground Equipment



Attachment 1
5000

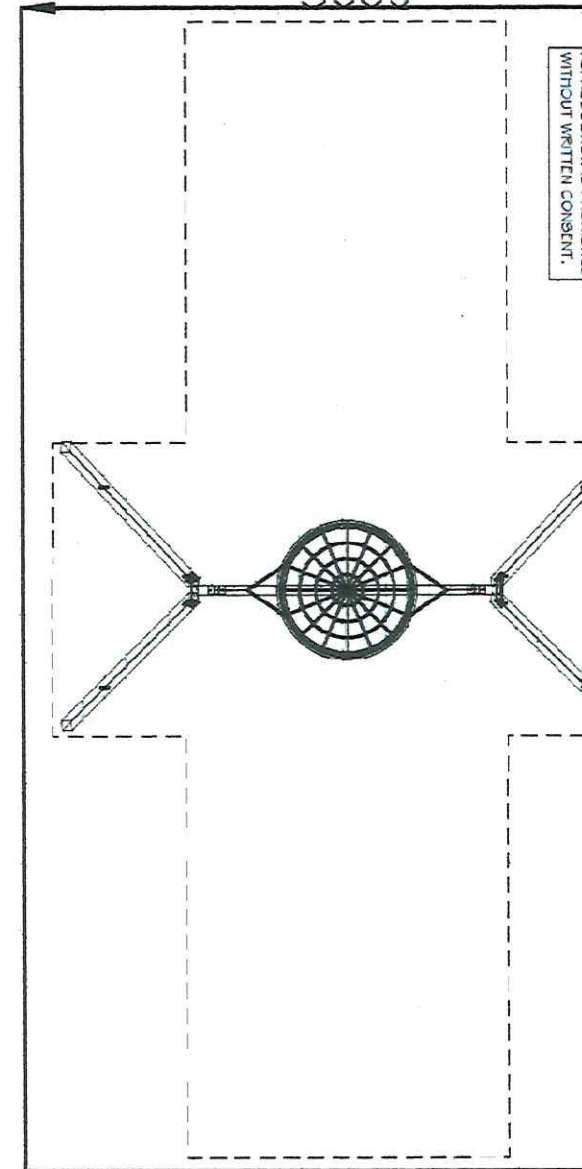

Swinging is important for children's development. It develops muscles and physical skills in legs, arms and fingers as well as building core strength and balance. It can stimulate and help to connect important neural pathways within the brain that are important for later learning. It is a favourite with children and adults of all ages. Swinging can be both exciting and relaxing and can encourage social or solitary play.

The bird's nest swing allows children of any age to enjoy the swinging motion that can be both comforting and exhilarating. It's woven net base offers a textured, flexible surface that gives total support and a wide shared surface area for the very young, adults or physically less able users.

WILBUR PARK 2019 (MARCH)



Community Chest : Retic Grant.



WILBUR PARK : 2020 JUNE

H.T.C. GRASSED & MAINTAINED.



26 August 2020

Dale Stewart
Chief Executive Officer
Shire of Narrogin
PO Box 1145
Narrogin WA 6312

To Mr Stewart

I am writing this letter in support of the Highbury Tennis Club application for an 'A' Frame Bird's Nest Swing for Wilbur Park in Highbury as part of the Shire of Narrogin Community Chest Fund.

Wilbur Park is an important asset to the Highbury Tennis Club and the broader Highbury community. It provides a place for community members to meet and participate in active play, which is an essential element of building healthy communities.

The updated park facilities of Wilbur Park forms part of the overall beautification of the Highbury area and aligns with the recent Strategic Planning undertaken by the Highbury District Council, that has been endorsed by the Shire.

Members of the Highbury Tennis Club have been active in the progress of this beautification project, regularly volunteering their time and resources to various projects. The installation of the 'A' Frame Bird's Nest Swing, will also be installed using local volunteers and resources, and will form our in-kind contribution to the Project.

Over recent years, the Highbury Tennis Club and Shire of Narrogin have built a strong and positive relationship that has seen some fantastic progress across our club and community. We are incredibly grateful for the Shire's support and look forward to this relationship continuing for many years to come.

Kind regards

Lauren Blight

President Highbury Tennis Club

Declaration

I declare that I am authorised to prepare and submit this application, and that the information presented is correct to the best of my knowledge

Name of President or Vice President

Lauren Blight

Signature of President or Vice President

L Blight

Date

25/8/2020

COMMUNITY CHEST APPLICATION FORM (FDRS010)



89 Earl Street
PO Box 1145
Narrogin WA 6312

(08) 9890 0900

www.narrogin.wa.gov.au
enquiries@narrogin.wa.gov.au

CASHIER HOURS:
8:30am – 4:30pm
MONDAY- FRIDAY

The Shire of Narrogin provides funding assistance through the biannual Community Chest funding program to eligible community organisations for events or projects which benefit the Narrogin community. To support the recovery of community groups following the COVID crisis, and for the financial year 2020/2021 cash and in-kind support is available up to a maximum of \$5,000. To further support the recovery process, successful applicants from 2019/2020 and 2018/2019 are eligible and invited to apply.

1. APPLICANT DETAILS

Name of Organisation

Highbury District Community

Postal Address

PO Box 350

Highbury

Contact Person

Mitchell Wray

Position

President

Phone

Email

Organisation's ABN

86 686 541 952

Is your organisation registered for GST?

Yes

Please attach a copy of your organisations Certificate of Incorporation

Certificate of Incorporation is attached

2. PROJECT DETAILS

What is the name of your proposed project or event?

Upgrade toilet facilities located between Highbury Hall and Highbury Tennis Club

Please provide a brief description of project / event (*maximum of 100 words*)

We would like to have solid doors fixed, windows sealed to stop dust and rubbish blowing in and garden

Bed out the front, possible paint inside and outside of the toilets.

How will your project / event benefit the Narrogin community?

The upgrade of the toilet block will allow the community to hold events such as cinema nights, picnics

and markets. We have our annual ANZAC service as well as the local dance clubs once a month.

The local tennis club also benefits with the toilet upgrade for when we have tournaments.

Estimated project start date

21-Sep-2020

Estimated project completion date

05-Oct-20

3. ADVERTISING AND PROMOTION

It is a requirement of funding approval that the words "*Sponsored by the Shire of Narrogin*" and the Shire's logo be displayed at /on your project/event.

Please check the boxes below to indicate the ways you will be able to acknowledge Shire of Narrogin sponsorship:

- Facebook, Instagram, or Twitter posts – please share with, and tag Shire of Narrogin page;
- Display Shire of Narrogin Logo: on your website and posters, in newspaper advertisements, on event signage, programs and flyers;
- Display the Shire of Narrogin flag or banner at your event if possible. (*Available upon request*)
- Affix Community Chest sign on project (*available on request*)
- Verbal announcements at event

4. PREVIOUS COMMUNITY CHEST FUNDING

Has your organisation previously received Community Chest funding?

Yes

If yes, please tell us what year, and describe the project and the amount of Community Chest funds received:

We received one back in 2016 for new oven, microwaves and heater, we also received one in 2019 for the
Water retic in Wilbur Park

5. PROJECT BUDGET

Are you applying for cash or in-kind support, or both (*up to a combined maximum of \$2,500*)?

Cash

If you are requesting an in-kind contribution, please provide details below:

Please tell us how the Community Chest funds will be used?

The community chest funds will be spent to improve the toilet facilities by stopping the elements filling the toilets with mess and the garden beds adding to the overall image of the façade of the toilet block.
These facilities are used by the patrons of events at the Highbury Town Hall and the local Highbury Tennis Club.

If you are requesting cash, do you require the Community Chest funds prior to your proposed event / activity?

No

In-kind contributions:

Please calculate and list below the value of any in-kind contributions and include in the Total Project Budget; (e.g. volunteer or donated labour.)

Volunteer and donated labour is calculated at \$25 per hour per person

<i>Contributions</i>	<i>Estimated value \$</i>
Installation of garden beds and soil/ plants	\$300.00
Painting of the toilet facilities	\$450.00

Project Income and Expenditure

INCOME		EXPENDITURE (please attach quotes)	
**Amount of Community Chest Funds requested in cash	\$4,213.83	Materials	\$4,213.83
**Amount of Community Chest funds requested in-kind (e.g. Town Hall hire fee waived if applicable /required).	\$	Hire of equipment:	\$
Applicant's cash contribution	\$	Venue hire	\$
In-kind (volunteer, donated labour)	\$750.00	Labour/contractor costs	Included in materials. See attached quotes. \$750.00 (Volunteer)
Sponsorship	\$	Advertising	\$
Donations (cash/materials from others- please list)	\$	Catering costs	\$
Other grants	\$	Entertainment	\$
Sales (stall fees, event tickets/food/merchandise)	\$	Office/administration	\$
Other income (please list)	\$	Other expenditure (please list)	\$
TOTAL *INCOME	\$4,963.83	TOTAL *EXPENDITURE	\$4,963.83

**Income and *Expenditure amounts must be equal*

***The total combined Community Chest cash and in-kind request cannot be greater than \$2,500.*

Declaration

I declare that I am authorised to prepare and submit this application, and that the information presented is correct to the best of my knowledge.

Name of President or Vice President

Mitchell Wray

Signature of President or Vice President

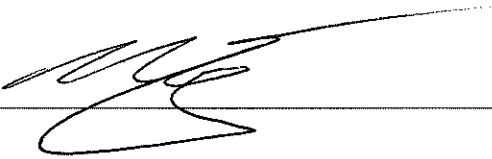

Date

31/08/20

ASSOCIATIONS INCORPORATION ACT 1987
SECTION 9 (1)

Registered No. **1004206**

Certificate of Incorporation

This is to certify that

**HIGHBURY DISTRICT COMMUNITY COUNCIL
INCORPORATED**

has this day been incorporated under the
Associations Incorporation Act 1987

Dated this **5th** day of **October 1994**

.....
FOR THE COMMISSIONER FOR CORPORATE AFFAIRS

Narrogin Valley Stockfeed

ABN:16 453 689 693

175 Federal Street Narrogin WA 6312

Ph: 9881 6000

Pip, Danni Porter

Store Credit
On Account\$0.00
-\$138.50

** Parked Sale **

Tax Invoice #NVS43248

10 Aug 2020 11:03am | Main Store

2	RAISED GARDEN BEDS ZINC / 2200 x 1100 x 400	@ \$255.00	\$510.00
2	SOILS GARDENMIX / 3 BUCKETS(1 CUBE)	@ \$120.00	\$240.00
1	Delivery Highbury	@ \$30.00	\$30.00
Subtotal			\$709.09
Tax (GST, 10%)			\$70.91
TOTAL 5 items			\$780.00
TO PAY			\$780.00

THANK YOU FOR SUPPORTING LOCAL BUSINESS

REFUNDS NOT ACCEPTED AFTER 14 DAYS

No: 689



Building the Future

31 Argus Street
 Narrogin WA 6312
 ABN: 81 413 282 413
 Builders Registration No: 13142

PH: 0408 958 856
 FAX: 08 9881 3140
 email: tyuenconstruction@y7mail.com

Quote

Date: 03-08-20
 ORDER No:

We have pleasure in submitting the following quotation for your consideration

To: The Highbury Community Council Attn: Dani Porter
 Re: Installation of doors to toilet block

Supply of materials and labour to install solid core doors with aluminium snap vents, pad bolts and rp3 weather strips with associated framing and cladding to enable installation of standard size doors (870 x 2040) with hardiflex cladding to top. Paintwork limited to door ends as discussed.

Sub Total: \$3,121.66

GST 10% \$312.17

Total: \$3,433.83

Note: If work is required to be done on weekends this quote will be invalid.

Quote is valid for 30 days

Signed: _____



"Out Side the Locker Room"

2 September 2020

To The Shire of Narrogin,

Last Blast of Summer

One of the most exciting and fuel powered events on the regional calendar that offers local business's a 'high traffic' opportunity. Held annually on the third weekend of March, this event is enjoyed by over 350 local and national spectators.

Association by way of sponsorship of this motor show will improve the Shire of Narrogin recognition, enhance your image and ensure you remain top of mind in the community.

The Narrogin Revheads committee has developed a unique automotive event which financially benefits locally based sporting clubs and community groups, enhances local community facilities, funds the Patient Assistant Transport Car and are proud sponsors to "Outside the Locker Room" mental health in sport and youth.

The one day of entertainment is provided in a controlled, safe and family friendly environment.

We wish to make an application for Community Chest funds of \$2500 to assist us in purchasing Marquee's to provide shade to our patron's instead of hiring them every year.

We acknowledge that you may receive many requests for sponsorship and donations. What sets us apart from the others is that assisting RevHeads the entire community benefits, rather than a single group.

If you have any queries please do not hesitate to call or email.

With Many Thanks,

Kylie Zolopa

Secretary

Mob: 0400864231

Narrogin Revheads Inc.





Government of **Western Australia**
Department of **Commerce**

WESTERN AUSTRALIA
Associations Incorporation Act 2015
(Section 10)

Registered No: A1021877J

Certificate of Incorporation

This is to certify that

NARROGIN REVHEADS INC.

is an association incorporated under the
Associations Incorporation Act 2015

The date of incorporation is the second day of March 2017

A handwritten signature in black ink, appearing to read 'David Hillyard'.

David Hillyard
Acting Commissioner for Consumer Protection

CERTIFICATE

Profit and Loss - Monthly (Excl GST) JUN 2018

	<u>Jun 2018</u>	<u>YTD</u>
<u>Income</u>		
Interest Received	0.15	2.49
Rev Heads Weekend	-	70,948.17
Revheads Sponsorship	-	6,409.08
Total Income	0.15	77,359.74
<u>Less: Expenses</u>		
Accountancy Fees	-	290.91
Accommodation	-	1,587.27
Advertising & Promotion	-	1,371.27
Alcohol & Drink Purchases	-	14,367.68
Band & Entertainment Expenses -	-	1,000.00
Band & Entertainment Expenses -	-	2,500.00
Bank Charges	-	64.20
Banklink Fees	-	221.77
Club House Expenses - Rev Head	-	1,707.19
Sporting/ Service Club - Rev Head	-	3,300.00
Filing Fees - ASIC	-	254.00
Food Purchases - With GST	-	2,181.64
Food Purchases - GST FREE	-	3,988.43
Fuel and Oil	-	476.82
Hire of Plant & Equipment	-	6,205.05
Insurance	-	3,145.45
Insurance premium	-	964.55
Insurance - Stamp Duty	-	430.10
Internet Fees	23.64	363.68
Licenses & Permits	-	356.29
Merchandise	-	3,100.00
Merchant Fees	148.72	969.20
Patron Entry Expenses	-	228.80
Postage, Printing & Stationery	-	526.90
Prize Money	-	16,000.00
Repairs & Maintenance	-	471.57
Security	-	8,778.12
Sundry Expenses - Rev Heads We	-	243.64
Trophies	-	1,752.73
Total Expenses	172.36	76,847.26
Operating Profit (Loss)	(172.21)	512.48
<u>Plus: Other Income</u>		
Sundry Income	-	909.09
Hire of Food Van & Equipment	-	363.63
Last Blast of Summer	-	5,580.00
Total Other Income	-	6,852.72
<u>Less: Other Expenses</u>		
Last Blast Night	-	2,848.86
Last Blast - GST Free	-	247.90
Total Other Expenses	-	3,096.76
Net Profit (Loss)	(172.21)	4,268.44

NARROGIN REVHEADS
LEDGER REPORT FROM 01/07/17 TO 30/06/18

Attachment 1

<u>Date</u>	<u>Reference</u>	<u>Narration</u>	<u>GST</u>	<u>\$ Gross</u>	<u>\$ GST</u>	<u>\$ Net</u>
<u>237 Last Blast of Summer</u>						
21/03/18 [D]		Last Blast of Summer Deposit	1	(6,138.00)	(558.00)	(5,580.00)
				(6,138.00)	(558.00)	(5,580.00)
<u>385 Last Blast Night</u>						
21/03/18		INTERNET TRANSFER LB Security	8	783.75	71.25	712.50
21/03/18		INTERNET TRANSFER LB Alcohol	8	1,368.00	124.36	1,243.64
21/03/18		INTERNET TRANSFER Liquor License LB	8	43.00	3.91	39.09
22/03/18		INTERNET TRANSFER LB Toilets Pumped	8	250.00	22.73	227.27
26/03/18		INTERNET TRANSFER LB Radio Ad	8	264.00	24.00	240.00
10/04/18		INTERNET TRANSFER Last Blast Toilet	8	425.00	38.64	386.36
				3,133.75	284.89	2,848.86
<u>386 Last Blast - GST Free</u>						
22/03/18		INTERNET TRANSFER LB Food Ngn Fresh	12	139.90	-	139.90
22/03/18		INTERNET TRANSFER LB Fish	12	64.80	-	64.80
23/04/18	1710	Bill & Bens	12	43.20	-	43.20
				247.90	-	247.90
				(2,756.35)	(273.11)	(2,483.24)

COMMUNITY CHEST APPLICATION FORM (FDRS010)



89 Earl Street
PO Box 1145
Narrogin WA 6312

(08) 9890 0900

www.narrogin.wa.gov.au
enquiries@narrogin.wa.gov.au

CASHIER HOURS:
8:30am – 4:30pm
MONDAY- FRIDAY

The Shire of Narrogin provides funding assistance through the biannual Community Chest funding program to eligible community organisations for events or projects which benefit the Narrogin community. To support the recovery of community groups following the COVID crisis, and for the financial year 2020/2021 cash and in-kind support is available up to a maximum of \$5,000. To further support the recovery process, successful applicants from 2019/2020 and 2018/2019 are eligible and invited to apply.

1. APPLICANT DETAILS

Name of Organisation

NARROGIN REVHEADS - LAST BLAST OF SUMMER

Postal Address

PO Box 1032 NARROGIN WA 6312

Contact Person

KYLIE ZOLOPA

Position

SECRETARY

Phone

[REDACTED]

Email

[REDACTED]

Organisation's ABN

72 233 927473

Is your organisation registered for GST? YES

Choose an item.

Please attach a copy of your organisations Certificate of Incorporation

Choose an item.

2. PROJECT DETAILS

What is the name of your proposed project or event?

LAST BLAST OF SUMMER

Please provide a brief description of project / event (maximum of 100 words)

Motor Sport Event held in March every year. Mini version of Revheads that attracts motor sport enthusiasts while all profits are put back into the community through sports clubs, PATS CAR, or other requests for help like the Narrogin BMX Club.

How will your project / event benefit the Narrogin community?

The event attracts approximately 350 people, providing local facilities exposure, an event that attracts locals and visitors while raising funds for the local sporting groups etc.

Estimated project start date

Estimated project completion date

Click here to enter a date. Sat 13th March 20 Click here to enter a date. Sat 13th March 20

3. ADVERTISING AND PROMOTION

It is a requirement of funding approval that the words "Sponsored by the Shire of Narrogin" and the Shire's logo be displayed at /on your project/event.

Please check the boxes below to indicate the ways you will be able to acknowledge Shire of Narrogin sponsorship:

- Facebook, Instagram, or Twitter posts – please share with, and tag Shire of Narrogin page;
- Display Shire of Narrogin Logo: on your website and posters, in newspaper advertisements, on event signage, programs and flyers;
- Display the Shire of Narrogin flag or banner at your event if possible. (Available upon request)
- Affix Community Chest sign on project (available on request)
- Verbal announcements at event

4. PREVIOUS COMMUNITY CHEST FUNDING

Has your organisation previously received Community Chest funding?

Only for Narrogin Revheads

Choose an item.

If yes, please tell us what year, and describe the project and the amount of Community Chest funds received:

5. PROJECT BUDGET

Are you applying for cash or in-kind support, or both (*up to a combined maximum of \$2,500*)?

Choose an item.

If you are requesting an in-kind contribution, please provide details below:

We wish to purchase marquee's for our event so we can provide our patron's with shade.

Please tell us how the Community Chest funds will be used?

As Above

If you are requesting cash, do you require the Community Chest funds prior to your proposed event / activity?

Choose an item.

In-kind contributions:

Please calculate and list below the value of any in-kind contributions and include in the Total Project Budget; (e.g. volunteer or donated labour.)

Volunteer and donated labour is calculated at \$25 per hour per person

Contributions	Estimated value \$
Approx 25 people @ 8 hours x \$25	\$5000

Project Income and Expenditure

INCOME		EXPENDITURE (please attach quotes)	
**Amount of Community Chest Funds requested in cash	\$ 2500	Materials	\$
**Amount of Community Chest funds requested in-kind (e.g. Town Hall hire fee waived if applicable /required).	\$	Hire of equipment:	\$ 675
Applicant's cash contribution	\$	Venue hire	\$ —
In-kind (volunteer, donated labour)	\$	Labour/contractor costs	\$ 783
Sponsorship	\$ N/A	Advertising	\$ 265
Donations (cash/materials from others- please list)	\$	Catering costs	\$1620 250
Other grants	\$	Entertainment	\$ 400
Sales (stall fees, event tickets/food/merchandise)	\$ 6852	Office/administration	\$
Other income (please list)	\$	Other expenditure (please list) Marquee's	\$ 2500
TOTAL *INCOME	\$ 9352	TOTAL *EXPENDITURE	6243

*Income and *Expenditure amounts must be equal

**The total combined Community Chest cash and in-kind request cannot be greater than \$2,500.

Based On 2018.

Declaration

I declare that I am authorised to prepare and submit this application, and that the information presented is correct to the best of my knowledge.

Name of President or Vice President

MR DAVID ANNEAR

Signature of President or Vice President



Date

31st AUGUST 2020

COMMUNITY CHEST APPLICATION FORM (FDRS010)



89 Earl Street
PO Box 1145
Narrogin WA 6312

(08) 9890 0900

www.narrogin.wa.gov.au
enquiries@narrogin.wa.gov.au

CASHIER HOURS:
8:30am – 4:30pm
MONDAY- FRIDAY

The Shire of Narrogin provides funding assistance through the biannual Community Chest funding program to eligible community organisations for events or projects which benefit the Narrogin community. To support the recovery of community groups following the COVID crisis, and for the financial year 2020/2021 cash and in-kind support is available up to a maximum of \$5,000. To further support the recovery process, successful applicants from 2019/2020 and 2018/2019 are eligible and invited to apply.

1. APPLICANT DETAILS

Name of Organisation

Narrogin Golf Club

Postal Address

PO Box 1041 Narrogin 6312

Contact Person

Shane Thornton

Position

Vice President

Phone

Email

Organisation's ABN

88020098852

Is your organisation registered for GST?

Yes

Please attach a copy of your organisations Certificate of Incorporation

Certificate of Incorporation is attached

2. PROJECT DETAILS

What is the name of your proposed project or event?

State Sand Greens 2021

Please provide a brief description of project / event (*maximum of 100 words*)

The State Sand Greens is the premier sand green event moving from different sand green golf courses on an annual basis. In 2021 Narrogin is due to hold the 40th anniversary of the event which draws field of over 200 for the four-day event.

How will your project / event benefit the Narrogin community?

The event will bring a large number of visitors over the four days of the event bringing a much-needed cash injection to the club as well as the town. Improvements to the course will also benefit the local members and green fee players that use the course

Estimated project start date

01-Jan-2020

Estimated project completion date

01-Sep-21

3. ADVERTISING AND PROMOTION

It is a requirement of funding approval that the words "Sponsored by the Shire of Narrogin" and the Shire's logo be displayed at /on your project/event.

Please check the boxes below to indicate the ways you will be able to acknowledge Shire of Narrogin sponsorship:

- Facebook, Instagram, or Twitter posts – please share with, and tag Shire of Narrogin page;
- Display Shire of Narrogin Logo: on your website and posters, in newspaper advertisements, on event signage, programs and flyers;
- Display the Shire of Narrogin flag or banner at your event if possible. (*Available upon request*)
- Affix Community Chest sign on project (*available on request*)
- Verbal announcements at event

4. PREVIOUS COMMUNITY CHEST FUNDING

Has your organisation previously received Community Chest funding?

Choose an item.

If yes, please tell us what year, and describe the project and the amount of Community Chest funds received:

Yes we received \$2500 in the 2019/2020 which was used to purchase a Bunker rake to improve the condition of the greens.

5. PROJECT BUDGET

Are you applying for cash or in-kind support, or both (*up to a combined maximum of \$5000*)?

Choose an item.

If you are requesting an in-kind contribution, please provide details below:

Cash

Please tell us how the Community Chest funds will be used?

We are looking to purchase some nut pickers to aid in the clean up of Honkey Nuts dropped from the red gum trees on course. At the moment the task is done using rakes and shovels which is slow and labour intensive, we are hoping the nut pickers will speed up this task resulting in a more attractive course

If you are requesting cash, do you require the Community Chest funds prior to your proposed event / activity?

Yes

In-kind contributions:

Please calculate and list below the value of any in-kind contributions and include in the Total Project Budget; (e.g. volunteer or donated labour.)

Volunteer and donated labour is calculated at \$25 per hour per person

Contributions	Estimated value \$
Purchase 1 push and 1 pull nut harvester	\$4156.90

Project Income and Expenditure

INCOME		EXPENDITURE (please attach quotes)	
**Amount of Community Chest Funds requested in cash	\$4156.90	Materials	\$4156.90
**Amount of Community Chest funds requested in-kind (e.g. Town Hall hire fee waived if applicable /required).	\$0	Hire of equipment:	\$
Applicant's cash contribution	\$	Venue hire	\$
In-kind (volunteer, donated labour)	\$2000.00	Labour/contractor costs	\$2000.00
Sponsorship	\$	Advertising	\$
Donations (cash/materials from others-please list)	\$	Catering costs	\$
Other grants	\$	Entertainment	\$
Sales (stall fees, event tickets/food/merchandise)	\$	Office/administration	\$
Other income (please list)	\$	Other expenditure (please list)	\$
TOTAL *INCOME	\$6156.90	TOTAL *EXPENDITURE	\$6156.90

*Income and *Expenditure amounts must be equal

**The total combined Community Chest cash and in-kind request cannot be greater than \$2,500.

Declaration

I declare that I am authorised to prepare and submit this application, and that the information presented is correct to the best of my knowledge.

Name of President or Vice President

Shane Thornton

Signature of President or Vice President



Date

27/08/2020



QUOTE

Shane Thornton
 NARROGIN WESTERN AUSTRALIA 6312
 AUSTRALIA

Date
 21 Aug 2020

Expiry
 4 Sep 2020

Quote Number
 QU-1718-0048

ABN
 70 611 116 708

NUT SOLUTIONS PTY LTD
 PO BOX 400
 PENGUIN TAS 7316
 AUSTRALIA
 www.nutsolutions.com.a
 u

Description	Quantity	Unit Price	GST	Amount AUD
18" Push Chestnut Harvester	1.00	1,195.00	10%	1,195.00
36" Pull-Behind Native Harvester	1.00	1,629.00	10%	1,629.00
Freight	1.00	955.00	10%	955.00
			Subtotal	3,779.00
			TOTAL GST 10%	377.90
			TOTAL AUD	4,156.90

Terms

This quote is valid for 14 days from the day of issue. If you have any queries with regards to this quote, please contact:

John Pethybridge
 0407 847 170
 john.pethybridge@gmail.com

Thank you for your business!



Department of Consumer & Employment Protection
Government of Western Australia

WESTERN AUSTRALIA

Associations Incorporation Act 1987
(Section 9(1))

Registered No.: A0520001X

Certificate of Incorporation

This is to certify that

THE NARROGIN GOLF CLUB

was on the eighth day of January 1952
incorporated under the *Associations Incorporation Act 1987*.

Commissioner for Fair Trading

This is a **REPLACEMENT CERTIFICATE** issued on the twentieth day of December 2004

COMMUNITY CHEST APPLICATION FORM (FDRS010)



89 Earl Street
PO Box 1145
Narrogin WA 6312

(08) 9890 0900

www.narrogin.wa.gov.au
enquiries@narrogin.wa.gov.au

CASHIER HOURS:
8:30am – 4:30pm
MONDAY- FRIDAY

The Shire of Narrogin provides funding assistance through the Community Chest to eligible community organisations for events or projects which benefit the general Narrogin community. Cash and in-kind support is available up to a maximum of \$2,500. Applications are to be submitted to the above by the closing date and must be acquitted within the financial year of approval.

1. APPLICANT DETAILS

Name of Organisation

UPPER GREAT SOUTHERN HOCKEY ASSOCIATION

Postal Address

P.O Box 240, Narrogin, WA, 6312

Contact Person

Rodney Johnson

Position

Development Officer

Phone

[REDACTED]

Email

ugshockeydo@gmail.com

Organisation's ABN

12547002356

Is your organisation registered for GST?

Yes

Please attach a copy of your organisations Certificate of Incorporation

Certificate of Incorporation is attached

2. PROJECT DETAILS

What is the name of your proposed project or event?

Upper Great Southern Hockey Association R U OK? Fixtured Round

Please provide a brief description of project / event (*maximum of 100 words*)

The Upper Great Southern Hockey Association in partnership with Holyoake WCADS Prevention Team (Wheatbelt Suicide Prevention Coordinator and the Alcohol and Other Drug Prevention Officer) will host an R U OK? Fixtured Hockey Round from Thursday 10th to Saturday 12th September 2020.

During the fixtured round , the newly developed 'Hey Sport R U OK?' campaign (<https://www.ruok.org.au/hey-sport-r-u-ok>) will be promoted and disseminated .

A Pre workshop will be held for all coaching and administrative staff where mental health literacy and suicide awareness information will be presented and disseminated. An incentivised program will be developed that will see UGSHA \$ (non-monetary tokens that can be redeemed at the canteen for food and non-alcoholic beverages) given out to all attendees.

All Teams within the UGSHA will receive an R U OK? Team Pack, which will include merchandise & factsheets from the R U OK? Foundation, and key messaging from the Alcohol. Think! Again & I Need You To Say No campaigns (developed by the WA Mental Health Commission), along with information on place-based (Mental Health, Alcohol and Social Support) services and where to access emergency 24/7 support.

An invitation from the UGSHA has been extended to Rachael Lynch (R U OK? Day Ambassador & Hockeyroo Goalkeeper) & Ashleigh Nelson (retired Hockeyroo) to attend the Event.

Triple M will be provided an Outside Broadcast on Saturday 12th September and will also provide lead in interviews with key personnel involved in the Event and short reads promoting the fixtured round.

All teams within the UGSHA will be encouraged to wear something yellow during the fixtured round and bring along a gold coin donation (all proceeds to go to the R U OK? Foundation). Prizes (R U OK? Campaign merchandise) will be awarded to a selection of senior and junior players under the categories of best dressed individual and best dressed team.

During the fixtured round youth friendly activities will be run that promote social connections and healthy lifestyles.

Prior to the Men's A Grade Fixture (Saturday evening) the Wheatbelt Suicide Prevention Coordinator will address players, officials and spectators and provide information on the importance of club connections, checking in on others and encouraging help seeking behaviours.

During the fixtured round, Alcohol. Think Again Campaign material will be displayed in toilets & the club rooms promoting low risk drinking, and promoting key messaging that no one should give alcohol to Under 18's.

How will your project / event benefit the Narrogin community?

During COVID 19 it has become apparent the many individuals are feeling overwhelmed and have gravitated to their sporting clubs as a source of support and connection. It is also been reported that during the COVID 19 pandemic and still during the Recovery Phase, that alcohol consumption has risen, and many individuals are consuming higher levels of alcohol as a maladaptive coping strategy.

The pre-event activity and activity undertaken during the Event will promote the R U OK? Foundation messaging whilst also promoting the importance of positive choices and healthy lifestyles. Information will also be available to parents on how to support young people to maintain optimum mental health, and make healthy lifestyle choices, and if required how to seek help and navigate the health sector.

During the Event, the WCADS Prevention team will be available to provide opportunistic support and advice to players, officials and spectators and promote placed based service providers and how and where to access support locally, over the phone and online.

Information will also be provided on further training and/or workshops opportunities that are available to members of the community, parents and youth on mental health literacy, suicide awareness/prevention and alcohol and other drug harm minimisation.

Estimated project start date

10-Sep-2020

Estimated project completion date

12-Sep-20

3. ADVERTISING AND PROMOTION

It is a requirement of funding approval that the words “*Sponsored by the Shire of Narrogin*” and the Shire’s logo be displayed at /on your project/event.

Please check the boxes below to indicate the ways you will be able to acknowledge Shire of Narrogin sponsorship:

- Facebook, Instagram, or Twitter posts – please share with, and tag Shire of Narrogin page;
- Display Shire of Narrogin Logo: on your website and posters, in newspaper advertisements, on event signage, programs and flyers;
- Display the Shire of Narrogin flag or banner at your event if possible (*available upon request*);
- Affix Community Chest sign on project (*available on request*); or
- Verbal announcements at event.

4. PREVIOUS COMMUNITY CHEST FUNDING

Has your organisation previously received Community Chest funding?

Yes

If yes, please tell us what year, and describe the project and the amount of Community Chest funds received:

2019 Narrogin Junior Carnival \$2500

5. PROJECT BUDGET

Are you applying for cash or in-kind support, or both (*up to a combined maximum of \$2,500*)?

Cash

If you are requesting an in-kind contribution, please provide details below:

Please tell us how the Community Chest funds will be used?

To help promote event through the Newspaper and Triple M
Printing of resource material for coaches and managers
Purchase promotional material from the RUOK Foundation

If you are requesting cash, do you require the Community Chest funds prior to your proposed event / activity?

Yes

In-kind contributions:

Please calculate and list below the value of any in-kind contributions and include in the Total Project Budget; (*e.g. volunteer or donated labour.*)

Volunteer and donated labour is calculated at \$25 per hour per person

<i>Contributions</i>	<i>Estimated value \$</i>

<i>Holyoake WCADS Prevention Team – pre event facilitation, Event attendance and Event presentations</i>	1000
<i>Facilities</i>	200

Project Income and Expenditure

INCOME		EXPENDITURE <i>(please attach quotes)</i>	
**Amount of Community Chest Funds requested in cash	\$2400	Materials	\$900
**Amount of Community Chest funds requested in-kind <i>(e.g. Town Hall hire fee waived if applicable /required)</i> .	\$	Hire of equipment:	\$
Applicant's cash contribution	\$100	Venue hire	\$
In-kind <i>(volunteer, donated labour)</i>	\$1200	Labour/contractor costs	\$1000
Sponsorship	\$500	Advertising	\$1000
Donations <i>(cash/materials from others-please list)</i>	\$	Catering costs	\$
Other grants	\$	Entertainment	\$
Sales <i>(stall fees, event tickets/food/merchandise)</i>	\$	Office/administration	\$1200
Other income <i>(please list)</i>	\$	Other expenditure <i>(please list)</i> UGS Dollars	\$100
TOTAL *INCOME	\$4200	TOTAL *EXPENDITURE	\$4200

**Income and *Expenditure amounts must be equal*

***The total combined Community Chest cash and in-kind request cannot be greater than \$2,500.*

Declaration

I declare that I am authorised to prepare and submit this application, and that the information presented is correct to the best of my knowledge.

Name of President or Vice President

Andrew Corner

Signature of President or Vice President

Andrew Corner

Date

21/08/2020

17/09/2020 06:55
15/11

COMMUNITY CHEST APPLICATION FORM (2020/21)



Shire of Narrogin
PO Box 1000
Narrogin WA 6342

Shire Narrogin

Shire Narrogin website
shireofnarrogin.wa.gov.au

Customer Service
1300 0 1300
1800 0 1300

The Shire of Narrogin provides funding assistance through the biennial Community Chest funding program to eligible community organisations for events or projects which benefit the Narrogin community. To support the recovery of community groups following the COVID crisis, and for the financial year 2020/2021 cash and in-kind support is available up to a maximum of \$5,000. To further support the recovery process, successful applicants from 2019/2020 and 2018/2019 are eligible and invited to apply.

1. APPLICANT DETAILS

Name of Organisation

NARROGIN GYMNASTICS CLUB

Postal Address

P.O. Box 1078 NARROGIN WA 6342

Contact Person

PAULA RAWORTH

Position

HEAD COACH

Phone



Email

narrogymclubsec@gmail.com

Organisation's ABN

295 413 947 55

Is your organisation registered for GST?

Yes



Please attach a copy of your organisations Certificate of Incorporation

Yes

No

2. PROJECT DETAILS

What is the name of your proposed project or event?

Installation of new under beam safety flooring

Please provide a brief description of project / event (maximum of 100 words)

This is our final stage in completing our upgrade of required safety flooring within our gym. The flooring is required for safe landing purposes and to reduce the incidences of ankle injuries in our young gymnasts. Our beam area encompasses three balance beams where gymnasts are performing acrobatic moves and dismounts from height. The specialized flooring is designed to be seamless and is 30mm thick. New flooring will help reduce the probability of trips and falls.

How will your project / event benefit the Narragansett community?

We currently have 50 children who all use this equipment on a weekly basis. These children are from Narragansett and surrounding towns. The new safety flooring will be particularly beneficial for all gymnasts who have additional needs and require extra assistance when using apparatus. It will also reduce the risk of injury to our coaches when assisting gymnasts on the beam, by providing a stable surface to stand on, as well as a safe surface for gymnasts to land on.

Estimated project start date

1-9-2020

Estimated project completion date

3-12-2020

3. ADVERTISING AND PROMOTION

As a requirement of funding approval, the logos displayed by the State of Narragansett and the State's logo be displayed at our project/event.

Please tick the boxes below or indicate the way you will be able to acknowledge State of Narragansett sponsorship.

- Facebook, Instagram, or Twitter posts – please share with, and tag State of Narragansett page
- Display State of Narragansett Logo on your website and posters, in newspaper advertisements, on email signage, programs and flyers.
- Display the State of Narragansett logo/ banner at your event, if possible. (Available upon request)
- Affix Community Chest sign on project materials on request
- Other arrangements at event

3. PREVIOUS COMMUNITY CHEST FUNDING

Has your organization previously received Community Chest funding?

Yes No

Type, please list by year, and describe the project and the amount of Community Chest funds received.

2015 New Garage Beam

2017 \$1500 contributed to the purchase of a horizontal bar, access platform and hoisting rings

4. PROJECT BUDGET

Are you seeking for cost or kind support, or both (up to a combined maximum of \$2,500)?

Cash \$1500

If you are requesting in-kind contributions, please include details below.

Please tell us how the Community Chest funds will be used:

The \$1500 will contribute (50% approx) towards the purchase of Coopered landing safety flooring and joining studs as well as freight cost to Nanaimo.

If you are seeking cash, do you require the Community Chest funds to be put into a special account?

Yes No

Declaration

I hereby certify that the information presented is true and correct to the best of my knowledge

Name of President or Vice President

Erin Rogers

Signature of President or Vice President



Date

29-8-2020

ACROMAT**SPORTS EQUIPMENT**Official Provider of
Gymnasium Equipment
to the Sydney 2000
Summer GamesOfficial Supplier
of the World
Gymnastics
ChampionshipsMember of the
FIG Equipment
AssociationCNO Trading Pty Ltd
Attn: 19 West 114 West
25 Macquarie Street
Brisbane QLD
South Australia 5001
Tel: 08 8352 2288
Fax: 08 8352 7043
Web site: www.acromat.com.au
Email: acromat@acromat.com.au

August 21, 2020

Attention: Paula Rowarth
Company: Nanogin Gymnastics Club
Lydiard Way
Nanogin WA 6312Phone No: [REDACTED]
Fax: [REDACTED]
Email: [REDACTED]

Dear Paula,

Reference: Gymnasium Equipment for Nanogin Gymnastics Club - WA
Quote ID: 00030733General Specifications: Refer ACROMAT gymnasium equipment specifications for detailed product information.

Due to a policy of continual improvement, Acromat reserve the right to supply improved products without notifying the customer.

Item No.	Code	Qty	Description	Supply Only Price including GST
1.	A8-371	8 ea.	Mat. Landing Carpeted, 3000 x 2000 x 200mm, FIG Approved.	\$17,186.40
2.	F71-10	1 ea.	Freight.	\$3,740.00

Prices: The prices include delivery and GST. The prices are firm for 60 days.Product Delivery:

Goods with no installation are delivered using contract couriers. It is the customer's responsibility to accept the goods from the carrier and to supply help if required. The customer must inform Acromat to arrange special delivery requirements when the goods are ordered. Additional charges may apply to special delivery arrangements.

Terms of payment:

- 1. Deposit of 25% with order
- 1. Balance within 30 days of delivery.

Bank Details:A/C Name: CNO Trading Pty Ltd
Branch: Westpac Temenoville SA
838 035 212 A/C No: 146722Aerobic Games & Sporting Equipment
reliable Tread Seating
and Manufactured by Acromat in AustraliaInternational
ISO Tel: +61 8 8352 2288
ISO Fax: +61 8 8352 7043

DUPLICATE

FORM 3

ASSOCIATIONS INCORPORATION ACT 1987 (SECTION 9(1))

CERTIFICATE OF INCORPORATION

No. : A824557

THIS IS TO CERTIFY THAT NARROGIN GYMNASTIC CLUB (INC)

has this day been incorporated under the Associations
Incorporation Act 1987.

DATED THIS Twenty Ninth DAY OF August 1989.



.....
FOR COMMISSIONER FOR
CORPORATE AFFAIRS



COMMUNITY CHEST APPLICATION FORM (FDRS010)



89 Earl Street
PO Box 1145
Narrogin WA 6312

(08) 9890 0900

www.narrogin.wa.gov.au
enquiries@narrogin.wa.gov.au

CASHIER HOURS:
8:30am – 4:30pm
MONDAY- FRIDAY

The Shire of Narrogin provides funding assistance through the biannual Community Chest funding program to eligible community organisations for events or projects which benefit the Narrogin community. To support the recovery of community groups following the COVID crisis, and for the financial year 2020/2021 cash and in-kind support is available up to a maximum of \$5,000. To further support the recovery process, successful applicants from 2019/2020 and 2018/2019 are eligible and invited to apply.

1. APPLICANT DETAILS

Name of Organisation

Avon Youth Community Services

Postal Address

55 Fairway Street NARROGIN WA 6312

Contact Person

Karen Walker

Position

Youth Worker

Phone

[REDACTED]

Email

Narrogin.youth@avoncs.org.au

Organisation's ABN

58 665 094 077

Is your organisation registered for GST?

Yes

Please attach a copy of your organisations Certificate of Incorporation

Certificate of Incorporation is attached

2. PROJECT DETAILS

What is the name of your proposed project or event?

Essential Skills

Please provide a brief description of project / event (*maximum of 100 words*)

The Essential skills program will run over 8 weeks teaching the indigenous youth of Narrogin life skills. We will teach them how to maintain a motor vehicle, such as changing tyres, checking their oil and water, we will also teach them how to do a basic service on their motor vehicles.

We will teach domestic skills from sewing on a button to fixing basic plumbing issues.

I will teach the youth how to budget, organise, and make decisions as a group for hosting their own event. (Last week of the essential skills will be an event at the youth centre for their families which they will organise and cook for)

How will your project / event benefit the Narrogin community?

The Essential skills program will provide and educate the Indigenous youth of Narrogin training and lifestyle skills.

It will provide minimal training skills to maintain their vehicles, educate the youth to procure or cook food, make healthy meal choices and basic domestic skills. It will also teach the youth planning, budgeting and organizing skills.

Estimated project start date

15-Oct-2020

Estimated project completion date

24-Dec-20

3. ADVERTISING AND PROMOTION

It is a requirement of funding approval that the words "*Sponsored by the Shire of Narrogin*" and the Shire's logo be displayed at /on your project/event.

Please check the boxes below to indicate the ways you will be able to acknowledge Shire of Narrogin sponsorship:

- Facebook, Instagram, or Twitter posts – please share with, and tag Shire of Narrogin page;
- Display Shire of Narrogin Logo: on your website and posters, in newspaper advertisements, on event signage, programs and flyers;
- Display the Shire of Narrogin flag or banner at your event if possible. (*Available upon request*)
- Affix Community Chest sign on project (*available on request*)
- Verbal announcements at event

4. PREVIOUS COMMUNITY CHEST FUNDING

Has your organisation previously received Community Chest funding?

Yes

If yes, please tell us what year, and describe the project and the amount of Community Chest funds received:

7th February to 27th March 2020 – Scooter Workshop

Together with Moorditj Youth, ACS received a community chest grant to run a 6 week program based around alcohol and drug use.

It allowed the youth of Narrogin to explore a sport/activity that wasn't offered in Narrogin.

5. PROJECT BUDGET

Are you applying for cash or in-kind support, or both (*up to a combined maximum of \$2,500*)?

Cash

If you are requesting an in-kind contribution, please provide details below:

Please tell us how the Community Chest funds will be used?

Purchasing car parts such as spark plugs, battery, hoses

Materials to make invitations and decorate the centre for the Christmas party

Groceries to produce healthy meals such as casseroles and salads

Food / cool drink for the grand finale of the program

If you are requesting cash, do you require the Community Chest funds prior to your proposed event / activity?

Yes

In-kind contributions:

Please calculate and list below the value of any in-kind contributions and include in the Total Project Budget; (*e.g. volunteer or donated labour.*)

Volunteer and donated labour is calculated at \$25 per hour per person

<i>Contributions</i>	<i>Estimated value \$</i>
Staff/administration costs	\$1000.00

Project Income and Expenditure

INCOME

EXPENDITURE (*please attach quotes*)

**Amount of Community Chest Funds requested in cash	\$2500	Car parts	\$500.00
**Amount of Community Chest funds requested in-kind (e.g. Town Hall hire fee waived if applicable /required).	\$	Hire of equipment:	\$
Applicant's cash contribution	\$	Venue hire	\$0
In-kind (volunteer, donated labour)	\$1000.00	Labour/contractor costs	\$900.00
Sponsorship	\$	Advertising	\$0
Donations (cash/materials from others-please list)	\$	Catering costs – groceries for teaching healthy recipes, groceries for grand finale	\$1000.00
Other grants	\$	Entertainment	\$
Sales (stall fees, event tickets/food/merchandise)	\$	Office/administration	\$600.00
Other income (please list)	\$	Cool drinks, water, items for grand finale	\$500.00
TOTAL *INCOME	\$3500.00	TOTAL *EXPENDITURE	\$3500.00

**Income and *Expenditure amounts must be equal*

***The total combined Community Chest cash and in-kind request cannot be greater than \$2,500.*

Declaration

I declare that I am authorised to prepare and submit this application, and that the information presented is correct to the best of my knowledge.

Name of ~~President or Vice President~~ CEO .

WAYNE MARTIN

Signature of President or Vice President

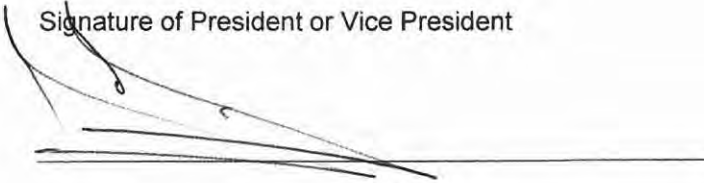

A handwritten signature in black ink, appearing to read 'Wayne Martin', is written over a horizontal line. The signature is stylized and somewhat cursive.

Date

31st AUGUST 2020



Extracted from ASIC's database at AEST 10:31:03 on 05/02/2019

Business name:	Avon Community Services
Status:	Registered
Registration date:	25/01/2018
Renewal date:	25/01/2022
Address for service of documents:	PO BOX 576 NORTHAM WA 6401 Australia
Principal place of business:	371 Fitzgerald St E Northam WA 6401
Holder(s) details:	Holder name: AVON YOUTH COMMUNITY AND FAMILY SERVICES
	Holder type: Other Incorporated Entity
	ABN: 58 665 094 077
Organisational Representative Details:	Name: Ian Allan Tate
	Start date: 25/01/2018
	Name: Wayne Martin
	Start date: 16/07/2018
Debtor representative(s):	not applicable
Notified successor(s):	not applicable
Regulator:	Australian Securities and Investments Commission

COMMUNITY CHEST APPLICATION FORM (FDRS010)



89 Earl Street
PO Box 1145
Narrogin WA 6312

(08) 9890 0900

www.narrogin.wa.gov.au
enquiries@narrogin.wa.gov.au

CASHIER HOURS:
8:30am – 4:30pm
MONDAY- FRIDAY

The Shire of Narrogin provides funding assistance through the biannual Community Chest funding program to eligible community organisations for events or projects which benefit the Narrogin community. To support the recovery of community groups following the COVID crisis, and for the financial year 2020/2021 cash and in-kind support is available up to a maximum of \$5,000. To further support the recovery process, successful applicants from 2019/2020 and 2018/2019 are eligible and invited to apply.

1. APPLICANT DETAILS

Name of Organisation

Rotary Club of Narrogin

Postal Address

PO Box 291 Narrogin WA 6312

Contact Person

Bronwen O'Sullivan

Position

President

Phone

[REDACTED]

Email

[REDACTED]

Organisation's ABN

86 217 792 110

Is your organisation registered for GST?

No

Please attach a copy of your organisations Certificate of Incorporation

Choose an item.

2. PROJECT DETAILS

What is the name of your proposed project or event?

Kerbside Numbers for Emergency Services

Please provide a brief description of project / event (*maximum of 100 words*)

Our club and the Lions club were approached to assist in fundraising and providing services to have every house in the town of Narrogin have prominent kerbside numbers.
Each house will need to be correctly identified and the numbers clearly painted in a consistent position which can be clearly seen from vehicles.
Currently the majority of the Houses in Narrogin do not have their identifying numbers displayed in such a manner that makes it easy for emergency services to find the house.

How will your project / event benefit the Narrogin community?

These will assist emergency services quickly and easily locate houses when necessary.
Currently many houses do not have house numbers or they are difficult to locate.
The easier it is for emergency services to find houses, the sooner services can be provided and lives saved.
Further they will assist others in locating houses, which will only assist other service providers and the community.

Estimated project start date

01-Sep-2020

Estimated project completion date

30-Jun-21

3. ADVERTISING AND PROMOTION

It is a requirement of funding approval that the words "*Sponsored by the Shire of Narrogin*" and the Shire's logo be displayed at /on your project/event.

Please check the boxes below to indicate the ways you will be able to acknowledge Shire of Narrogin sponsorship:

- Facebook, Instagram, or Twitter posts – please share with, and tag Shire of Narrogin page;
- Display Shire of Narrogin Logo: on your website and posters, in newspaper advertisements, on event signage, programs and flyers;
- Display the Shire of Narrogin flag or banner at your event if possible. *(Available upon request)*
- Affix Community Chest sign on project *(available on request)*
- Verbal announcements at event

4. PREVIOUS COMMUNITY CHEST FUNDING

Has your organisation previously received Community Chest funding?

Choose an item.

If yes, please tell us what year, and describe the project and the amount of Community Chest funds received:

Not known

5. PROJECT BUDGET

Are you applying for cash or in-kind support, or both *(up to a combined maximum of \$2,500)*?

Cash

If you are requesting an in-kind contribution, please provide details below:

Assistance in identification of the houses from records kept at the Shire of Narrogin

Please tell us how the Community Chest funds will be used?

To assist in the payment of the painting of the numbers.

We are intending to make application for other funding such as *All West Australians Reducing Emergencies* (AWARE) and Lotteries West to raise the full amount.

Given the number of houses (2297) it is not thought it is viable for this to be completed through volunteers and as such we have obtained a quote from a company who has completed similar projects in other towns. Local quotes are also being sought.

If you are requesting cash, do you require the Community Chest funds prior to your proposed event / activity?

Yes

In-kind contributions:

Please calculate and list below the value of any in-kind contributions and include in the Total Project Budget; (e.g. volunteer or donated labour.)

Volunteer and donated labour is calculated at \$25 per hour per person

<i>Contributions</i>	<i>Estimated value \$</i>
<i>Not known how long it will take to provide the information in relation to the houses</i>	

Project Income and Expenditure

INCOME		EXPENDITURE (please attach quotes)	
**Amount of Community Chest Funds requested in cash	\$5000E	Materials	\$
**Amount of Community Chest funds requested in-kind (e.g. Town Hall hire fee waived if applicable /required).	\$	Hire of equipment:	\$
Applicant's cash contribution	\$	Venue hire	\$
In-kind (volunteer, donated labour)	\$	Labour/contractor costs	\$30000E
Sponsorship	\$	Advertising	\$

Donations (<i>cash/materials from others-please list</i>)	\$	Catering costs	\$
Other grants	\$25000E	Entertainment	\$
Sales (<i>stall fees, event tickets/food/merchandise</i>)	\$	Office/administration	\$
Other income (<i>please list</i>)	\$	Other expenditure (<i>please list</i>)	\$
TOTAL *INCOME	\$30000E	TOTAL *EXPENDITURE	30000E

**Income and *Expenditure amounts must be equal*

***The total combined Community Chest cash and in-kind request cannot be greater than \$2,500.*

Declaration

I declare that I am authorised to prepare and submit this application, and that the information presented is correct to the best of my knowledge.

Name of President or Vice President

Bronwyn O'Neil

Signature of President or Vice President



Date

30/8/2020

DUPLICATE

A822464

Form 5



Certificate of Incorporation

*Associations Incorporation Act 1895-1982
Section 3 (3)*

These are to Certify that ROTARY CLUB OF NARROGIN (INC)

has this day been incorporated as an Association under the provisions of
the Associations Incorporation Act, 1895-1982.

Dated this Twenty Fifth day of November 19 86 .



39349/3/85-6M-S/7507

N. b. Dwy
ASSISTANT COMMISSIONER FOR CORPORATE
AFFAIRS.

I CERTIFY the within to be a True Copy
of/Extract From the Document which it
purports to be a Copy/Extracted from.

Dated the - 8 MAY 2000







TOP COLOUR

PO Box 3003, Kingsley 6026, Western Australia

Town of Narrogin

Kerb Numbering Quotation

Quote Date: 26/08/2020

Client: Town of Narrogin



Who we are

Top Colour is Western Australia's most experienced reflective kerb number painting company. With over 23 years experience, and proudly West Australian family-owned, we strive to provide the community with a quality safety product using only the finest materials.

Our Proposal

We would like to firstly thank you for the opportunity to quote on our service to paint kerb numbers in the Town of Narrogin.

Our standard pricing for a single dwelling is \$25.00 per kerb number, however we are pleased to offer you a 50% discount for the total of 2297 properties. Please note that as Narrogin is a regional town, the fee will incur a regional surcharge of \$500 to cover travel time and petrol.

The works should be completed within a 3 week period from the commencement date as long as the weather permits.

Total Dwellings	Price Per Number
2297	\$12.50
Sub Total for 2297	\$28,712.50
Total inc Surcharge	\$29,212.50

Please note this quote is valid 30 days from the quote date. Please also note that Top Colour is not registered for GST.

Thank you

Thank you again for your time and for considering Top Colour. We look forward to hearing from you. Should you have any questions regarding our proposal, please do not hesitate to contact Mirek on 0418 923 685 or email us at info@topcolour.com.au.

15.1.1 / 1PM 2021 437.

COMMUNITY CHEST APPLICATION FORM (FDRS010)



89 Earl Street
PO Box 1145
Narrogin WA 6312

(08) 9890 0900

www.narrogin.wa.gov.au
enquiries@narrogin.wa.gov.au

CASHIER HOURS:
8:30am – 4:30pm
MONDAY- FRIDAY

The Shire of Narrogin provides funding assistance through the biannual Community Chest funding program to eligible community organisations for events or projects which benefit the Narrogin community. To support the recovery of community groups following the COVID crisis, and for the financial year 2020/2021 cash and in-kind support is available up to a maximum of \$5,000. To further support the recovery process, successful applicants from 2019/2020 and 2018/2019 are eligible and invited to apply.

1. APPLICANT DETAILS

Name of Organisation

Narrogin Primary School Parents and Citizens Association

Postal Address

C/O Narrogin Primary School
Williams Road
Narrogin WA 6312

Contact Person

Ms Filipa Walmsley

Position

Convenor

Phone

[REDACTED]

Email

phchenhard@un.com.au

Organisation's ABN

57676500984

Is your organisation registered for GST? **No**

Please attach a copy of your organisations Certificate of Incorporation

Certificate of Incorporation is attached

2. PROJECT DETAILS

What is the name of your proposed project or event?

Narrogin Voice Festival

Please provide a brief description of project / event (*maximum of 100 words*)

Narrogin Primary School is planning to host the 'Narrogin Voice Festival' to provide an opportunity for choir students from our school and nearby schools to showcase their talent due to the cancellation of One Big Voice in Perth. Together with the choir, who will recreate One Big Voice in the Narrogin context, there will be a focus on displaying local talented artists and sharing of Noongar song and music to acknowledge the land's traditional custodians and to acknowledge NAIDOC week. This event will be held in the evening of Friday 13 November and will be promoted as a whole community event.

How will your project / event benefit the Narrogin community?

During difficult times in Narrogin due to Covid, business and rural downturn, cancellation of community events (eg Narrogin Show), our outcome is to bring joy, a sense of celebration and community to enhance the mental health and well-being of shire residents. This event will be inclusive. The opportunity to attend will be made available to all shire residents, inclusive of the elderly and those with disability. Planning is in place to live stream the event to locations such as Karinya.

The production will be high quality and able to be enjoyed by an audience seated on picnic rugs on the school oval, looking up at our talented children and guest artists on a raised bank. There will be some tables and seating available. There will be opportunity provided for local businesses and voluntary organisations, to raise much needed funds by operating stalls (predominantly food and beverage) prior to and during the event, thus adding to the ambience of the carnival atmosphere.

Approaches are currently being made to the Narrogin Police and local community groups such as the Lions Club for their input, involvement and contribution.

If this event is successful, consideration will be given to providing this event in future years.

Estimated project start date

13-Nov-2020

Estimated project completion date

13-Nov-20

3. ADVERTISING AND PROMOTION

It is a requirement of funding approval that the words "*Sponsored by the Shire of Narrogin*" and the Shire's logo be displayed at /on your project/event.

Please check the boxes below to indicate the ways you will be able to acknowledge Shire of Narrogin sponsorship:

- Facebook, Instagram, or Twitter posts – please share with, and tag Shire of Narrogin page;
- Display Shire of Narrogin Logo: on your website and posters, in newspaper advertisements, on event signage, programs and flyers;
- Display the Shire of Narrogin flag or banner at your event if possible. (*Available upon request*)
- Affix Community Chest sign on project (*available on request*)
- Verbal announcements at event

4. PREVIOUS COMMUNITY CHEST FUNDING

Has your organisation previously received Community Chest funding?

No

If yes, please tell us what year, and describe the project and the amount of Community Chest funds received:

Not applicable

5. PROJECT BUDGET

Are you applying for cash or in-kind support, or both (*up to a combined maximum of \$5,000*)?

Choose an item.

If you are requesting an in-kind contribution, please provide details below:

Not applicable

Please tell us how the Community Chest funds will be used?

Funding will be utilised to meet the costs of staging the event. Being community funding, we would utilise this grant money to improve the ambience of the event for participants (quality lighting and sound, fairy lights) and to make the event accessible and visible for all. To facilitate a maximisation of participation, grant money would also contribute to seating and accessibility for the elderly and disabled and to the hire of a large LED screen which would enhance visibility and atmosphere and enable us to live stream to locations such as Karinya. The LED screen will additionally provide us with the capacity to record the event for posterity and for future viewing. (And potentially a fund raising opportunity for our organisation).

If you are requesting cash, do you require the Community Chest funds prior to your proposed event / activity?

Yes

In-kind contributions:

Please calculate and list below the value of any in-kind contributions and include in the Total Project Budget; (*e.g. volunteer or donated labour.*)

Volunteer and donated labour is calculated at \$25 per hour per person

<i>Contributions</i>	<i>Estimated value \$</i>
Volunteer Labour – Narrogin Primary School P&C – 44 hours	\$1100
Volunteer Labour – Event Organisation and Choir Preparation –Narrogin Primary School admin team and staff – 90 hours	\$2250
TOTAL	\$3350

Project Income and Expenditure

INCOME		EXPENDITURE <i>(please attach quotes)</i>	
**Amount of Community Chest Funds requested in cash	\$5000.00	Materials (estimated cost)	\$650.00
**Amount of Community Chest funds requested in-kind <i>(e.g. Town Hall hire fee waived if applicable /required)</i> .	\$ --	<u>Hire of equipment:</u> Toilet trailer hire - \$340 Hire of tables and chairs - \$641.90 Hire of fairy lights and laser - \$563 Marquee Hire – \$1544.40 Audio Visual/Power – \$3633.19 Hire of LED panel - \$3052.50	\$9775
Applicant's cash contribution	\$2300	Venue hire	\$ - nil
In-kind <i>(volunteer, donated labour)</i>	\$3350	<u>Labour/contractor costs:</u> Marquee Transport - \$748 Power Audio Visual Labour – \$2700.50 LED Delivery and Crew - \$264 Security - \$2468.40	\$6181
Sponsorship <i>(currently investigating in order to reduce cost to Narrogin Primary School)</i> .	\$ nil-	Advertising & Ticketing (estimated cost)	\$400
Donations <i>(cash/materials from others- please list)</i>	\$ -	Catering costs (estimated cost)	\$1100
Other grants <i>(currently investigating to reduce costs to Narrogin Primary School)</i>	\$ nil	Entertainment	\$
Sales (stall fees, event tickets/food/merchandise) 400 tickets @ \$5.00 Stall Hire Fee 6 X \$50.00	\$2500	Office/administration Five additional days – NPS school officer @ \$393.43 per day.	\$1967
Other income <i>(please list)</i> <i>Narrogin Primary School Funding</i>	\$7998	<u>Other expenditure <i>(please list)</i></u> Copyright agreement – One Big Voice - \$420.00 Choir Shirts/Uniform - \$654.50	\$1075
TOTAL *INCOME	\$21 148	TOTAL *EXPENDITURE	\$21 148

*Income and *Expenditure amounts must be equal

**The total combined Community Chest cash and in-kind request cannot be greater than \$5,000.

Declaration

I declare that I am authorised to prepare and submit this application, and that the information presented is correct to the best of my knowledge

Name of President or Vice President

FILIPA RUTH WALMSLEY

Signature of President or Vice President



Date

28/8/2020



Government of Western Australia
Department of Mines, Industry Regulation and Safety
Consumer Protection

WESTERN AUSTRALIA
Associations Incorporation Act 2015
(Section 10)

IARN: A0821267R

Certificate of Incorporation

This is to certify that

**NARROGIN PRIMARY SCHOOL PARENTS AND CITIZENS'
ASSOCIATION INCORPORATED**

is an association incorporated under the
Associations Incorporation Act 2015

The date of incorporation is the
twenty first day of August 1984

A handwritten signature in black ink, appearing to be 'Lanie Chopping'.

Lanie Chopping
Commissioner for Consumer Protection

CERTIFICATE



14 Remisko Dr Forrestdale WA 6112
 Tel: (08) 9399 6283
 A/Hrs: 0409 204 927
 Email: info@c-eventhire.com.au
 Web: c-eventhire.com.au
 ABN: 94 114 727 383

QUOTATION			
Clerk	Date	Trs No	
CEM	26/08/2020	17732	
Order NO			
660			
Quote	Cust Po	Res No.	Ctr No.
0		0	0

Customer ID	98821700	Terms	0 Days	Ship To	
NARROGIN PRIMARY SCHOOL PO BOX 107 NARROGIN, 6312 (08) 9882 1700		NARROGIN PRIMARY SCHOOL 22-24 WILLIAMS ROAD NARROGIN, 6312 DAVID HARRISON (08) 9882 1700			
Rental agent	Carolyn Martin		Event Name		
Ordered By:			Event Date	13/11/2020	Event time 05:00 PM / 10:00 PM
Shipping		Return			
Date	Time		Date	Time	
13/11/2020	08:00 AM		14/11/2020	09:00 AM	
Delivery Note: * INSTALL & REMOVAL DAYS TO BE ADVISED *					
Qty	Item Code	Description	Unit Price	Total	
1	1103	MARQUEE 9 X 12 ROBIAN STRUCTURE - Extended Legs Front	1404.00	1404.00	
Payment Methods : Cash , Cheque , Direct Debit , Visa and Mastercard. we do not accept Amex or Dinners. Bank Details: ANZ-BSB: 016-022 A/C: 4969 13136 Overdue account will be charged a monthly fee of \$5.00			Sub-Total	2084.00	
			Transport	680.00	
			Discounts	0.00	
			GST	208.40	
			Total	2292.40	
			Payment	0.00	
			Balance	2292.40	
I have read and agree with the terms and conditions		initials			

Customer's Name

Customer's Signature

Date

Quotation

Quantity	Item	Unit Price	Days	Discount	Total
2	Case Black Soft Zipped	\$0.00	1.0		\$0.00
2	SM58 Shure	\$15.00	1.0	25%	\$22.50
2	Microphone Clip - SM58 / SM57 Size	\$0.00	1.0		\$0.00
2	Black Zip-up Microphone Case	\$0.00	1.0		\$0.00
2	SM57 Shure	\$15.00	1.0	25%	\$22.50
2	Microphone Clip - SM58 / SM57 Size	\$0.00	1.0		\$0.00
2	Black Zip-up Microphone Case	\$0.00	1.0		\$0.00
6	PG81 Shure	\$20.00	1.0	25%	\$90.00
6	PG81 Microphone Clip Shure	\$0.00	1.0		\$0.00
2	DI Active AR133 BSS Audio	\$15.00	1.0	25%	\$22.50
2	9V Battery	\$0.00	1.0		\$0.00
10	Stand Microphone - Tall Boom	\$5.00	1.0	25%	\$37.50
2	Stand Microphone - Short Boom	\$5.00	1.0	25%	\$7.50
1	Audio Cables - Tour Package	\$0.00	1.0		\$0.00
Subtotal for Audio - Microphones					\$292.50

Lighting

1	MQ40 Chamsys	\$200.00	1.0	25%	\$150.00
1	Road Case (no casters)	\$0.00	1.0		\$0.00
1	Powercon Power Cable	\$0.00	1.0		\$0.00
4	DMX 5pin Male to 3pin Female XLR	\$0.00	1.0		\$0.00
1	LED Lamp - powered by 3pin XLR	\$0.00	1.0		\$0.00
4	Profile 1000w	\$25.00	1.0	25%	\$75.00
4	Truss Clamp 100kg	\$0.00	1.0		\$0.00
4	Safety Chain	\$0.00	1.0		\$0.00
6	Intimidator Spot 360	\$100.00	1.0	25%	\$450.00
6	Powercon Power Cable	\$0.00	1.0		\$0.00
6	Safety Chain	\$0.00	1.0		\$0.00
6	Truss Clamp 100kg	\$0.00	1.0		\$0.00
6	Chauvet Intimidator Trio Moving Head	\$100.00	1.0	25%	\$450.00
2	Stand Lighting - T	\$10.00	1.0	25%	\$15.00
2	Stand Lighting - T Bar Top	\$0.00	1.0		\$0.00
1	3 Phase 32amp Distribution - 12 x 10amp sockets	\$25.00	1.0	25%	\$18.75
2	3 Phase 32amp - 20m	\$15.00	1.0		\$30.00
1	Antari Smoke F-7 SMAZE	\$120.00	1.0	25%	\$90.00
1	Powercon Power Cable	\$0.00	1.0		\$0.00
1	Lighting Cables - Tour Package	\$0.00	1.0		\$0.00



Phone: 08 9385 6996 URL: www.powermusic.com.au
 Email: hire@powermusic.com.au ABN: 40 143 653 445
 Address: 12 Graylands Rd Claremont WA 6010 ACN:
 Postal Address: 12 Graylands Rd, Claremont WA 6010

Quotation

Quantity	Item	Unit Price	Days	Discount	Total
Subtotal for Lighting					\$1,278.75
Cable Management					
35	Cable Tray - 2 Channel	\$12.50	1.0	25%	\$328.13
Subtotal for Cable Management					\$328.13
Staging					
7	Stage 2.4x1.2m	\$60.00	1.0	25%	\$315.00
14	Stage Nut, Bolt and Washers - 80mm	\$0.00	1.0		\$0.00
14	Stage Static leg 300mm	\$0.00	1.0	25%	\$0.00
Subtotal for Staging					\$315.00
Crew					
1	Delivery - Truck 4.5T	\$120.00	2.0 hours		\$240.00
1	Collection - Truck 4.5T	\$120.00	2.0 hours		\$240.00
2	AV Technician - Day Rate	\$700.00	1.0		\$1,400.00
2	Bump Out 1	\$70.00	4.0 hours		\$560.00
1	Accomodation	\$15.00	0.0		\$15.00
Subtotal for Crew					\$2,455.00
Rental Total	\$3,302.90	Discount			\$1,090.96
Sale Total	\$15.00	Subtotal			\$5,757.90
Service Total	\$2,440.00	GST Total			\$575.79
Total Including GST					\$6,333.69



URL: www.powermusic.com.au
 Phone: 08 9385 6996 ABN: 40 143 653 445
 Email: hire@powermusic.com.au ACN:
 Address: 12 Graylands Rd Claremont WA 6010
 Postal Address: 12 Graylands Rd, Claremont WA 6010

Quotation

Quantity	Item	Unit Price	Days	Discount	Total
Subtotal for Lighting					\$1,278.75
Cable Management					
35	Cable Tray - 2 Channel	\$12.50	1.0	25%	\$328.13
Subtotal for Cable Management					\$328.13
Staging					
7	Stage 2.4x1.2m	\$60.00	1.0	25%	\$315.00
14	Stage Nut, Bolt and Washers - 80mm	\$0.00	1.0		\$0.00
14	Stage Static leg 300mm	\$0.00	1.0	25%	\$0.00
Subtotal for Staging					\$315.00
Crew					
1	Delivery - Truck 4.5T	\$120.00	2.0 hours		\$240.00
1	Collection - Truck 4.5T	\$120.00	2.0 hours		\$240.00
2	AV Technician - Day Rate	\$700.00	1.0		\$1,400.00
2	Bump Out 1	\$70.00	4.0 hours		\$560.00
1	Accomodation	\$15.00	0.0		\$15.00
Subtotal for Crew					\$2,455.00
<hr/>					
Rental Total	\$3,302.90	Discount			\$1,090.96
Sale Total	\$15.00	Subtotal			\$5,757.90
Service Total	\$2,440.00	GST Total			\$575.79
Total Including GST					\$6,333.69

Quotation

Project ID: PA00413 Date: 27/08/2020
 Project Name: Narrogin - LED Screen and Live Stream Delivery Date:
 Client: Narrogin Primary School Return Date:
 Contact Number: 0419881433 Address: Narrogin Primary School
 22-24 Williams Road
 Narrogin WA 6312

Quantity	Item	Unit Price	Days	Total
LED Screen				
1	LED Trailer Screen	\$2,000.00	1.0	\$2,000.00
			Subtotal for LED Screen	\$2,000.00
Vision - Hardware				
1	ATEM Mini Pro	\$110.00	1.0	\$110.00
1	HDMI 3m Cable	\$0.00	1.0	\$0.00
1	Transformer Power Supply	\$0.00	1.0	\$0.00
1	USBC Cable - A-C	\$0.00	1.0	\$0.00
1	Case Black Plastic	\$0.00	1.0	\$0.00
1	Panasonic Lumix G95 24-70mm Lens	\$150.00	1.0	\$150.00
1	Panasonic PTZ and Controller w/ 50m SDI	\$375.00	1.0	\$375.00
2	SDI to HDMI Converter	\$30.00	1.0	\$60.00
1	Fluid Head Tripod	\$35.00	1.0	\$35.00
1	Computer Monitor	\$30.00	1.0	\$30.00
			Subtotal for Vision - Hardware	\$760.00
Cables				
3	HDMI 3m Cable	\$0.00	1.0	\$0.00
1	Cat6 Cable with Ethercon Connectors 70m	\$15.00	1.0	\$15.00
1	Power Cable IEC Short	\$0.00	1.0	\$0.00
			Subtotal for Cables	\$15.00
Crew				
1	Delivery - Van	\$60.00	2.0 hours	\$120.00
1	Collection - Van	\$60.00	2.0 hours	\$120.00
			Subtotal for Crew	\$240.00
Rental Total	\$2,775.00	Subtotal	\$3,015.00	
Sale Total	\$0.00	GST Total	\$301.50	
Service Total	\$240.00	Total Including GST	\$3,316.50	

NARROGIN HIRE SERVICE AND RETICULATION

ABN: 83 414 757 986

DAN AND BERNICE BLYTH
132 FEDERAL STREET
BOX 118
NARROGIN.....W.A.6312

Ph. (08) 98812266 Fax (08) 98814446

TAX INVOICE

NARROGIN PRIMARY SCHOOL
WILLIAMS ROAD
NARROGIN W.A. 6312

Invoice #: 00027308

Date: 27/08/2020

Page No: 1

QTY.	ITEM NO.	DESCRIPTION	PRICE	UNIT	TOTAL
	/-	QUOTE FOR MUSIC EVENING			
10	TABLLGH	TABLES LARGE ROUND	\$11.80		\$118.00
10	TCLOTH ROH	TABLE CLOTH ROUND	\$12.75		\$127.50
100	CHAH	CHAIRS	\$2.00		\$200.00
8	TCLOTHSMROH	TABLE CLOTH SM ROU	\$12.75		\$102.00
8	TABLCOCKTH	TABL COCKTAILH	\$11.80		\$94.40

BANK ACCOUNT DETAILS: BSB: 066-522 - ACC NO: 1005-1539

Invoice #: 00027308

NARROGIN PRIMARY SCHOOL
WILLIAMS ROAD
NARROGIN W.A. 6312

TOTAL EXC GST	\$583.55
GST COMPONENT	\$58.35
TOTAL INCLUDING GST	\$641.90
PAID TODAY	\$0.00
BALANCE DUE	\$641.90

NARROGIN HIRE SERVICE AND RETICULATION

ABN: 83 414 757 986

DAN AND BERNICE BLYTH
132 FEDERAL STREET
BOX 118
NARROGIN.....W.A.6312

Ph. (08) 98812266 Fax (08) 98814446

TAX INVOICE

NARROGIN PRIMARY SCHOOL
WILLIAMS ROAD
NARROGIN W.A. 6312

Invoice #: 00027309

Date: 27/08/2020

Page No: 1

QTY.	ITEM NO.	DESCRIPTION	PRICE	UNIT	TOTAL
4	/- TOIL/TRAILERH	quote for music night New Item	\$85.00		\$340.00

BANK ACCOUNT DETAILS: BSB: 066-522 - ACC NO: 1005-1539

Invoice #: 00027309

NARROGIN PRIMARY SCHOOL
WILLIAMS ROAD
NARROGIN W.A. 6312

TOTAL EXC GST	\$309.09
GST COMPONENT	\$30.91
TOTAL INCLUDING GST	\$340.00
PAID TODAY	\$0.00
BALANCE DUE	\$340.00



Perth Party Hire

103 Nicholson Road Subiaco W A 6008
 Phone: 9382 2088
 Info@perthpartyhire.com.au
 Www.perthpartyhire.com.au
 A B N: 81 676 535 404

CUSTOMER CONTRACT

Invoice No: NP201031
Event Date: 31/10/2020
Company Contact:

Invoice To

Narrogin Primary School
 22-24
 Williams Rd
 NARROGIN WA 6312

Customer to Collect

Collection Date: Wed, 28 Oct
Collection Time:
Return Date: Tue, 3 Nov
Return Time:

Phone:

9882 1700

Product	Qty	Price	(GST included)Amount
Flood Light 500 Watt	6	\$18.00	\$108.00
Fairy Light 30m Led Supply Only	1	\$35.00	\$35.00
Fairy Light 60meters Led Supply Only	2	\$60.00	\$120.00
Snake Lights	4	\$20.00	\$80.00
Flood Light 2 X 500w Twin On Stand	3	\$40.00	\$120.00
Safety Switch Outlet 4 Gpo	2	\$15.00	\$30.00
Rave Laser L E D Effects Light Dance	1	\$70.00	\$70.00

SubTotal: \$563.00

Total: \$563.00

(Included GST) : \$51.18

Amount Due: \$563.00

Conditions of hire: The Hirer Accepts full responsibility for the correct use and or operation of the hire equipment and acknowledges receiving the equipment in good working order. Any problems that the hirer encounters are to be reported within 6 hours of receiving the goods or no refund will apply. As part of the contract the hirer acknowledges having read this and the full terms and conditions available on our web site. Any equipment or packaging not returned clean or damaged or missing by the due date will incur a cleaning fee or the full replacement cost.

Payment Options For Perth Party Hire

Cash, Cheque, Debit/Credit Card or EFT

We Accept



Payment By Credit Card
 Attracts a 2% Surcharge

Banking Details

National Bank
 BSB: 086 082
 Acc No: 534995671



Please note.
 2018 Invoice. Supplier has guaranteed same price for same number of shirts for this event

ABN 66 062 107 988

PO BOX 1179
 NARROGIN WA 6312
 Ph: 0417 957 018
 Email: embroiderme@bigpond.com

Tax Invoice

Date	Tax Invoice #
29/07/2018	725

Tax Invoice To
Narrogin Primary School PO BOX 107 NARROGIN WA 6312

P.O. No.	Terms

Description	Qty	Rate	Tax	TAX AMT	Amount
Supply and Heat set to back and front of Choir shirts as requested	17	35.00	GST	59.50	595.00

Account Payment Authorisation		
Supply satisfactorily received by:	<i>M</i>	Date: 13/8/18
I certify that this account is correct in respect of the requirements of Treasurer's Instruction 304(4) (i) to (vii)		
Michelle Edwards	<i>M Edwards</i>	13/8/18
Incurring Officer's Name	Signature & Date	
I certify that this account is correct in respect of the requirements of Treasurer's Instruction 304(4)		
Harrison	<i>Harrison</i>	13/8/18
Confirming Officer's Name	Signature & Date	
Budget/Account Code	Cheque No.:	Amount
D5710	1	654.50
	GST Code	

13 AUG 2018

5817

Subtotal	\$595.00
Tax	\$59.50
Total	\$654.50
Payments/Credits	\$0.00
Balance Due	\$654.50

DIRECT DEBIT BANKING DETAILS
 Bank: Westpac Bank
 Account Name: Embroider Me
 BSB no: 036 167
 Account no: 228802



TAX INVOICE

Narrogin Primary School
22-24 Williams Road
NARROGIN WA 6312

Invoice Date 13 Dec 2019
Invoice Number INV-3291
Reference O/No 1742
ABN 28 239 540 149

One Big Voice Festival
C/- 27 Blaxland Way
PADBURY WA 6025

Description	Quantity	Unit Price	GST	Amount AUD
Choir Registration - 2020 Festival (26-50 students)	1.00	420.00	10%	420.00
			Subtotal	420.00
			TOTAL GST 10%	42.00
			TOTAL AUD	462.00
			Less Amount Paid	462.00
			AMOUNT DUE AUD	0.00

Due Date: 27 Dec 2019

Online Payments: Bendigo Bank Kingsway
BSB 633 000
Account No 156 278 921
Please quote name and Invoice no.

PAYMENT ADVICE

Customer Narrogin Primary School
Invoice Number INV-3291
Amount Due 0.00
Due Date 27 Dec 2019

To: One Big Voice Festival
C/- 27 Blaxland Way
PADBURY WA 6025

**Amount
Enclosed**

Enter the amount you are paying above

Narrogin Voice Festival



Fairy Lights overhead/in trees



Marquee Hire from Perth \$1900



Picnic Style Seating (BYO Blanket/Cushion)

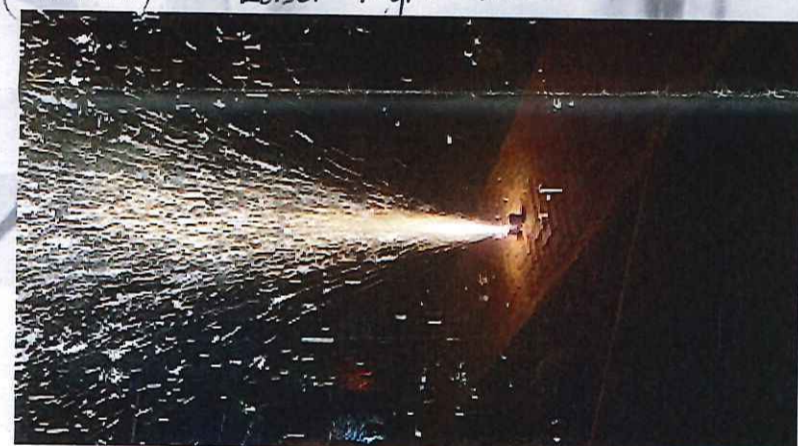

(Fireworks) Laser Light Show



Hire of Sound System and Lighting



Guest Artists to open the Festival - local talent (various locations around oval)



Consider Bar Option (licence?)

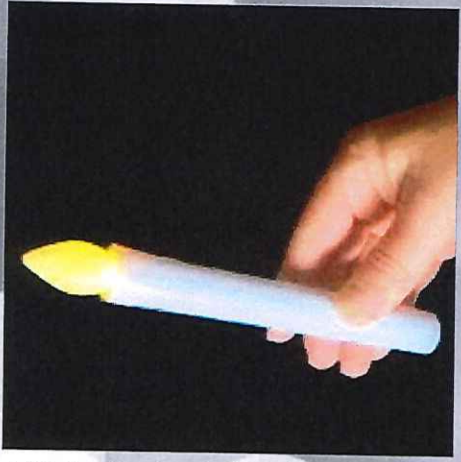

LED Candles (or similar) for sale to wave during key songs.



Raffle Ticket Sales for Donated Prizes

Food Stalls by P&C or Invited stallholders— consider cover charge? Popcorn/Coffee/Bar?



Cheeseboard Option (Pre-order)



Showbags?



Seek Corporate



Narrogin Voice Festival
 Proposed layout (to be confirmed)

COMMUNITY CHEST APPLICATION FORM (FDRS010)



89 Earl Street
PO Box 1145
Narrogin WA 6312

(08) 9890 0900

www.narrogin.wa.gov.au
enquiries@narrogin.wa.gov.au

CASHIER HOURS:
8:30am – 4:30pm
MONDAY- FRIDAY

The Shire of Narrogin provides funding assistance through the biannual Community Chest funding program to eligible community organisations for events or projects which benefit the Narrogin community. To support the recovery of community groups following the COVID crisis, and for the financial year 2020/2021 cash and in-kind support is available up to a maximum of \$5,000. To further support the recovery process, successful applicants from 2019/2020 and 2018/2019 are eligible and invited to apply.

1. APPLICANT DETAILS

Name of Organisation

Narrogin Agricultural Society Inc.

Postal Address

PO Box 357 NARROGIN WA 6312

Contact Person

Vicki Chadwick

Position

President

Phone

[Redacted]

Email

[Redacted]

Organisation's ABN

83 663 633 803

Is your organisation registered for GST?

No

Please attach a copy of your organisations Certificate of Incorporation

Certificate of Incorporation is attached

2. PROJECT DETAILS

What is the name of your proposed project or event?

Opening of Community Park

Please provide a brief description of project / event (*maximum of 100 words*)

Grand opening of the NRLC Community Open Park at the Narrogin Regional Leisure Centre, commencing at 2.00pm.
Including blow up water obstacle, bouncy castle, activities for children, food vans and movie in the evening.
Incorporate official opening at 2.30pm by the Shire President, Mr Leigh Ballard, of the Community Park.

How will your project / event benefit the Narrogin community?

Family friendly
Easy access into Community Park from Clayton Road and NRLC car park.

Estimated project start date

20-Feb-2021

Estimated project completion date

20-Feb-21

3. ADVERTISING AND PROMOTION

It is a requirement of funding approval that the words "*Sponsored by the Shire of Narrogin*" and the Shire's logo be displayed at /on your project/event.

Please check the boxes below to indicate the ways you will be able to acknowledge Shire of Narrogin sponsorship:

- Facebook, Instagram, or Twitter posts – please share with, and tag Shire of Narrogin page;
- Display Shire of Narrogin Logo: on your website and posters, in newspaper advertisements, on event signage, programs and flyers;
- Display the Shire of Narrogin flag or banner at your event if possible. (*Available upon request*)
- Affix Community Chest sign on project (*available on request*)

Verbal announcements at event

4. PREVIOUS COMMUNITY CHEST FUNDING

Has your organisation previously received Community Chest funding?

Choose an item.

If yes, please tell us what year, and describe the project and the amount of Community Chest funds received:

The Narrogin Agricultural Society has been receiving funding previous to the Community Chest from the Shire for a number of years.
Since the amalgamation of the Shire & Town Council, the Shire of Narrogin contributes \$2500 cash and \$2500 in kind. Previous to the amalgamation we received \$2000 from each Council.

5. PROJECT BUDGET

Are you applying for cash or in-kind support, or both (*up to a combined maximum of \$2,500*)?

Cash

If you are requesting an in-kind contribution, please provide details below:

Please tell us how the Community Chest funds will be used?

Payment of hire costs of Giant outdoor games with supervisors, blow up 4m Movie Screen including
Projector/PA and staff member to set up, copyrights fee, movie & bean bags freight delivery costs.

If you are requesting cash, do you require the Community Chest funds prior to your proposed event / activity?

Yes

In-kind contributions:

Please calculate and list below the value of any in-kind contributions and include in the Total Project Budget; (e.g. volunteer or donated labour.)

Volunteer and donated labour is calculated at \$25 per hour per person

<i>Contributions</i>	<i>Estimated value \$</i>
<i>Events Volunteer Staff x 6</i>	<i>\$900</i>
<i>Administration grant/acquittal x 1 (6 hours)</i>	<i>\$150</i>

Project Income and Expenditure

INCOME		EXPENDITURE (please attach quotes)	
**Amount of Community Chest Funds requested in cash	\$4000	Materials	\$
**Amount of Community Chest funds requested in-kind (e.g. Town Hall hire fee waived if applicable /required).	\$	Hire of equipment:	\$4000
Applicant's cash contribution	\$500	Venue hire	\$200
In-kind (volunteer, donated labour)	\$	Labour/contractor costs	\$
Sponsorship SoN pay venue hire	\$200	Advertising	\$500
Donations (cash/materials from others-please list)	\$	Catering costs	\$
Other grants	\$	Entertainment	\$
Sales (stall fees, event tickets/food/merchandise)	\$	Office/administration	\$
Other income (please list)	\$	Other expenditure (please list)	\$
TOTAL *INCOME	\$4700	TOTAL *EXPENDITURE	\$4700

**Income and *Expenditure amounts must be equal*

***The total combined Community Chest cash and in-kind request cannot be greater than \$2,500.*

Declaration

I declare that I am authorised to prepare and submit this application, and that the information presented is correct to the best of my knowledge.

Name of President or Vice President

Vicki Chadwick

Signature of President or Vice President

VChadwick

Date

30/08/2020

15.1.1

Narrogin Eagles Sporting Club Inc

Po Box 299

Narrogin WA 6312

ABN 20 071 330 130

7th October 2017

Please find enclosed application for community chess funding.

If this project is accepted for funding I will forward engendering plans and specifications to you.



Regards David Annear.



89 Earl Street
PO Box 1145
Narrogin WA 6312

(08) 9800 0900

www.narrogin.wa.gov.au
enquiries@narrogin.wa.gov.au

CASHER HOURS:
8:30am – 4:30pm
MONDAY- FRIDAY

The Shire of Narrogin provides funding assistance through the biannual Community Chest funding program to eligible community organisations for events or projects which benefit the Narrogin community. To support the recovery of community groups following the COVID crisis, and for the financial year 2020/2021 cash and in-kind support is available up to a maximum of \$5,000. To further support the recovery process, successful applicants from 2019/2020 and 2018/2019 are eligible and invited to apply.

1. APPLICANT DETAILS

Name of Organisation

Narrogin Eagles Sporting Club

Postal Address

39 Bannister St Narrogin WA 6312

Contact Person

David Annear

Position

Committee Member

Phone

[REDACTED]

Email

annear@westnet.com.au

Organisation's ABN

20 071 330 130

Is your organisation registered for GST?

Yes

Please attach a copy of your organisations Certificate of Incorporation

Certificate of Incorporation is attached

2. PROJECT DETAILS

What is the name of your proposed project or event?

Construction of steel roof/cover for the front apron of the Narrogin Eagles Sporting club

Please provide a brief description of project / event (*maximum of 100 words*)

The narrogin eagles sporting club would like to install a steel cover Roof/cover to match the existing building roof line

8m x 6m

How will your project / event benefit the Narrogin community?

Provide a sunsmart space for users of the Thomas hogg oval

Provide coverage for entertainment events for patrons and musicians alike

Enabling an amputheatre type experience when utilizing the stage area towards the oval.

Enhancing the community spirit to enable more entrainment opportunities with an enhanced facility.

Estimated project start date

15-Sep-2020

Estimated project completion date

15-Oct-20

3. ADVERTISING AND PROMOTION

It is a requirement of funding approval that the words "*Sponsored by the Shire of Narrogin*" and the Shire's logo be displayed at /on your project/event.

Please check the boxes below to indicate the ways you will be able to acknowledge Shire of Narrogin sponsorship:

- Facebook, Instagram, or Twitter posts – please share with, and tag Shire of Narrogin page;
- Display Shire of Narrogin Logo: on your website and posters, in newspaper advertisements, on event signage, programs and flyers;
- Display the Shire of Narrogin flag or banner at your event if possible. (*Available upon request*)
- Affix Community Chest sign on project (*available on request*)

Verbal announcements at event

4. PREVIOUS COMMUNITY CHEST FUNDING

Has your organisation previously received Community Chest funding?

Yes

If yes, please tell us what year, and describe the project and the amount of Community Chest funds received:

Previously applied for \$2k that was accepted though not utilised. As the funds limit has been increased we would like to apply for the increased amount in preparation for this year's Narrogin Revheads Event

5. PROJECT BUDGET

Are you applying for cash or in-kind support, or both (*up to a combined maximum of \$2,500*)?

Cash

If you are requesting an in-kind contribution, please provide details below:

Total \$4,840

Please tell us how the Community Chest funds will be used?

To purchase materials from local businesses

If you are requesting cash, do you require the Community Chest funds prior to your proposed event / activity?

Yes

In-kind contributions:

Please calculate and list below the value of any in-kind contributions and include in the Total Project Budget; (e.g. volunteer or donated labour.)

Volunteer and donated labour is calculated at \$25 per hour per person

<i>Contributions</i>	<i>Estimated value \$</i>
<i>Labour</i>	<i>\$1,000</i>

Project Income and Expenditure

INCOME		EXPENDITURE (please attach quotes)	
**Amount of Community Chest Funds requested in cash	\$4840	Materials	\$4840
**Amount of Community Chest funds requested in-kind (e.g. Town Hall hire fee waived if applicable /required).	\$	Hire of equipment:	\$
Applicant's cash contribution	\$	Venue hire	\$
In-kind (volunteer, donated labour)	\$1000	Labour/contractor costs	\$
Sponsorship	\$	Advertising	\$
Donations (cash/materials from others-please list)	\$	Catering costs	\$
Other grants	\$	Entertainment	\$
Sales (stall fees, event tickets/food/merchandise)	\$	Office/administration	\$
Other income (please list)	\$	Other expenditure (please list)	\$
TOTAL *INCOME	\$5840	TOTAL *EXPENDITURE	4840

**Income and *Expenditure amounts must be equal*

***The total combined Community Chest cash and in-kind request cannot be greater than \$2,500.*

Declaration

I declare that I am authorised to prepare and submit this application, and that the information presented is correct to the best of my knowledge.

Name of President or Vice President

DAVID ANNIEAR

Signature of President or Vice President

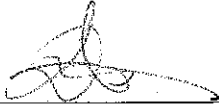

Date

27 - 08 - 2020



Quote

Invoice No.: 00000215

Date: 26/08/2020

Cnr Albany Hwy & Narrogin Rd
 PO Box 169, WILLIAMS, WA, 6391
 Office: 08 9830 9414
 tracey@pricesfabricationandsteel.com.au
 www.pricesfabricationandsteel.com.au
 ABN: 77 638 026 150

Bill To:

Narrogin Eagles Sporting Club
 Thomas Hogg Oval
 Bannister St
 Narrogin WA 6312

Ship To:

DESCRIPTION	AMOUNT	CODE
Supply materials and labour to fabricate 8m x 6m lean-to for the Narrogin Eagles Sporting Club	\$4,840.00	GST

SHED PAYMENT TERMS

GST: \$440.00

- 4 payment schedule as outlined in shed quote
 (deposit, start of fabrication, start of installation & completion)
- Due 7 days from invoice

Total Inc GST: \$4,840.00

Amount Applied: \$0.00

BSB: 086 852

Balance Due: \$4,840.00

Account No: 91 209 7036

Account name: Price's Fabrication and Steel

Please reference your surname

*** PLEASE NOTE NEW BANK ACCOUNT DETAILS ***



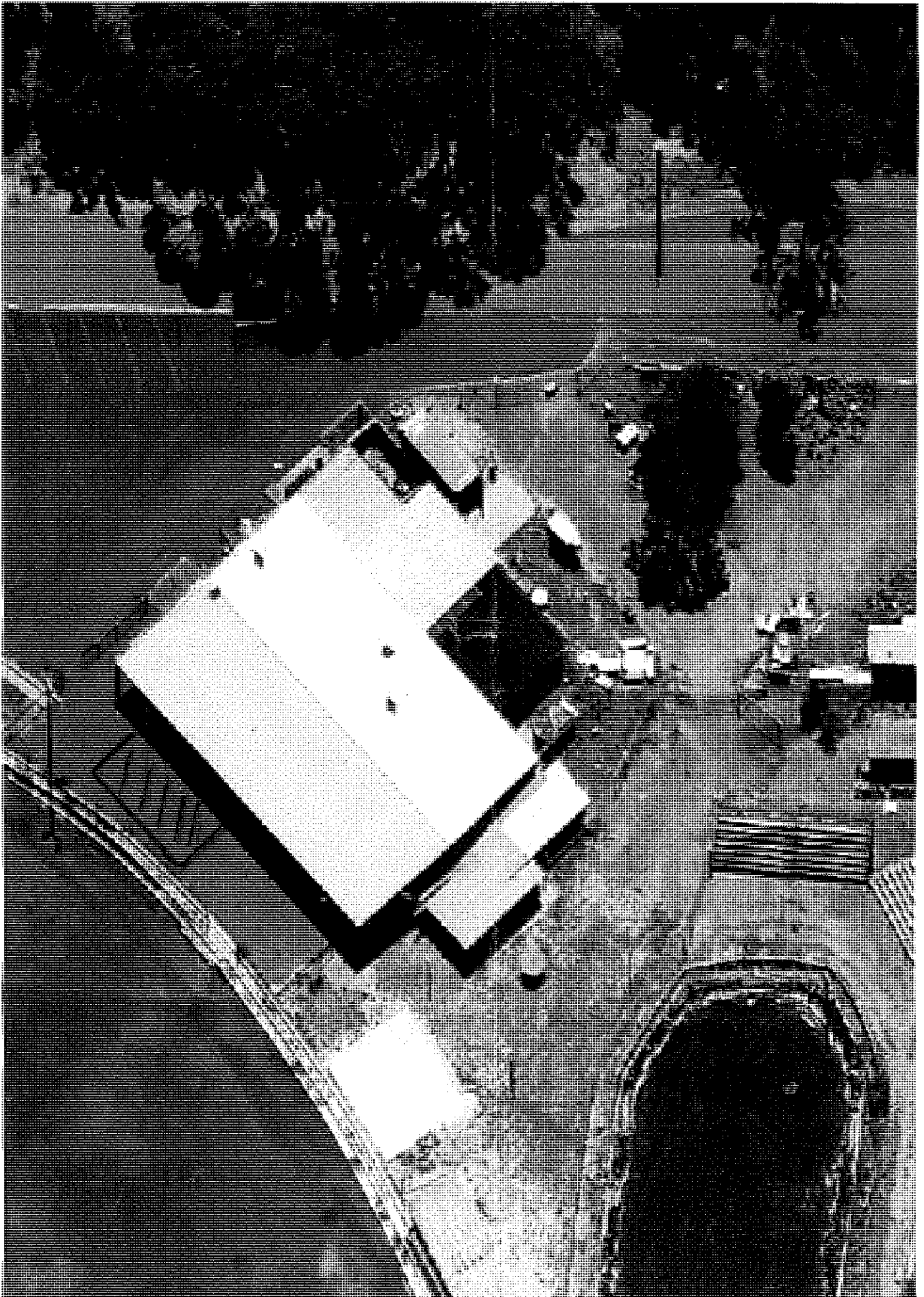

COMMUNITY CHEST APPLICATION FORM (FDRS010)



89 Earl Street
PO Box 1145
Narrogin WA 6312

(08) 9890 0900

www.narrogin.wa.gov.au
enquiries@narrogin.wa.gov.au

CASHIER HOURS:
8:30am – 4:30pm
MONDAY- FRIDAY

The Shire of Narrogin provides funding assistance through the biannual Community Chest funding program to eligible community organisations for events or projects which benefit the Narrogin community. To support the recovery of community groups following the COVID crisis, and for the financial year 2020/2021 cash and in-kind support is available up to a maximum of \$5,000. To further support the recovery process, successful applicants from 2019/2020 and 2018/2019 are eligible and invited to apply.

1. APPLICANT DETAILS

Name of Organisation

WA Police and Community Youth Centres – Narrogin Blue Light Unit

Postal Address

Level 1, 55 Salvado Street, Subiaco 6009

Contact Person

Heidi Melia (Narrogin based) for information about the project
Colleen Henry (Perth based) for information about the application or organisation

Position

Heidi Melia - Blue Light Unit Supervisor
Colleen Henry – Manager Projects and Grants

Phone

[Redacted]

Email

[Redacted]

Organisation's ABN

18 727 953 078

Is your organisation registered for GST?

Yes

Please attach a copy of your organisations Certificate of Incorporation

Certificate of Incorporation is attached

2. PROJECT DETAILS

What is the name of your proposed project or event?

Back to School Blue Light 2021

Please provide a brief description of project / event (*maximum of 100 words*)

Narrogin Blue Light will host a free COVID-19 community event at the end of the summer school holidays for all youth in Narrogin. It will be held with the support of local schools and community groups with laser tag and other activities planned to facilitate positive engagement with Police and other community organisations. Building strong relationships between Police and young people is part of our local strategy to help reduce the occurrence of crime involving young people in Narrogin.

How will your project / event benefit the Narrogin community?

The Narrogin community will benefit immensely from this event as part of the recovery from the impact of COVID-19. The money from this grant will be spent locally, allowing the Blue Light unit to pay for all expenses, rather than rely on donations from local businesses, who have all been heavily impacted by the restrictions of COVID-19.

Previous events run in the same manner demonstrated a high number of positive interactions between youth, police, education and the community in general, with support for future events.

A reduction in youth crime means more young people are able to positively contribute to our community. Diverting young people away from offending and reducing the perception of youth offending in the community will contribute to the satisfaction and security of all residents.

Encouraging all youth to re-engage in education will benefit the Narrogin community as they will be less likely to be committing offences and more likely to impact less on resources such as Police, Health and Justice systems. Studies have shown that engagement with school assists students in all aspects of their lives, including employment, community life and personal skills.

Estimated project start date

29-Jan-2021

Estimated project completion date

29-Jan-21

3. ADVERTISING AND PROMOTION

It is a requirement of funding approval that the words "*Sponsored by the Shire of Narrogin*" and the Shire's logo be displayed at /on your project/event.

Please check the boxes below to indicate the ways you will be able to acknowledge Shire of Narrogin sponsorship:

- Facebook, Instagram, or Twitter posts – please share with, and tag Shire of Narrogin page;
- Display Shire of Narrogin Logo: on your website and posters, in newspaper advertisements, on event signage, programs and flyers;
- Display the Shire of Narrogin flag or banner at your event if possible. (*Available upon request*)
- Affix Community Chest sign on project (*available on request*)
- Verbal announcements at event

4. PREVIOUS COMMUNITY CHEST FUNDING

Has your organisation previously received Community Chest funding?

Yes

If yes, please tell us what year, and describe the project and the amount of Community Chest funds received:

Yes – 2018/2019 we received \$2500.

5. PROJECT BUDGET

Are you applying for cash or in-kind support, or both (*up to a combined maximum of \$2,500*)?

Cash

If you are requesting an in-kind contribution, please provide details below:

Not applicable.

Please tell us how the Community Chest funds will be used?

The funds will cover the hire of the Laser Tag, advertising costs and other hired entertainment for the day. It will also cover basic food and drinks for all attendees.

If you are requesting cash, do you require the Community Chest funds prior to your proposed event / activity?

Yes

In-kind contributions:

Please calculate and list below the value of any in-kind contributions and include in the Total Project Budget; (*e.g. volunteer or donated labour.*)

Volunteer and donated labour is calculated at \$25 per hour per person

<i>Contributions</i>	<i>Estimated value \$</i>
<i>Police donated labour - 15 people at \$25/hr for 3 hours</i>	<i>\$1125</i>
<i>Other services donated labour - 15 people at \$25/hr for 3 hours</i>	<i>\$1125</i>

Project Income and Expenditure

INCOME		EXPENDITURE (please attach quotes)	
**Amount of Community Chest Funds requested in cash	\$5000	Materials	\$0
**Amount of Community Chest funds requested in-kind (e.g. Town Hall hire fee waived if applicable /required).	\$	Hire of equipment:	\$1090 Laser Tag \$1000 Waterslide \$500 Dunk Tank \$150 BBQ Hire \$500 Bouncy Castle Hire
Applicant's cash contribution	\$	Venue hire	\$
In-kind (volunteer, donated labour)	\$ 2250	Labour/contractor costs	\$2250
Sponsorship	\$	Advertising Signs (\$300) Banner (\$300) Leaflets (\$150)	\$ 750
Donations (cash/materials from others-please list) Gazebos, eskys, tables	\$ 250	Catering costs Sausages, rolls, sauce, trays, napkins, bottles of water, ice, icy poles	\$ 600
Other grants	\$	Entertainment	\$
Sales (stall fees, event tickets/food/merchandise)	\$	Office/administration	\$
Other income (please list)	\$	Other expenditure (please list) Hire equipment (generator, electronic sign)	\$ 660
TOTAL *INCOME	\$7500	TOTAL *EXPENDITURE	\$7500

**Income and *Expenditure amounts must be equal*

***The total combined Community Chest cash and in-kind request cannot be greater than \$5,000.*

Declaration

I declare that I am authorised to prepare and submit this application, and that the information presented is correct to the best of my knowledge.

Name of President or Vice President

CEO

DAVID VAN COORAN

Signature of President or Vice President

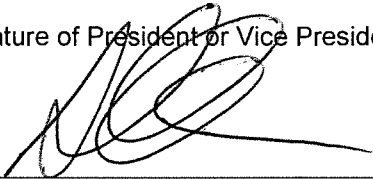

Date

31/8/20



Department of Consumer & Employment Protection
Government of Western Australia

WESTERN AUSTRALIA
Associations Incorporation Act 1987
(Section 18(6))

Registered No: A0410007J

Certificate of Incorporation on Change of Name

This is to certify that

**THE FEDERATION OF WESTERN AUSTRALIAN POLICE AND CITIZENS'
YOUTH CLUBS (INC.)**

which was on the sixth day of June 1941
incorporated under the *Associations Incorporation Act 1987*
changed its name on the fifteenth day of September 2005 to:

**THE FEDERATION OF WESTERN AUSTRALIAN POLICE AND
COMMUNITY YOUTH CENTRES (INC)**

Dated this fifteenth day of September 2005

Commissioner for Fair Trading

CERTIFICATE

COMMUNITY CHEST APPLICATION FORM (FDRS010)



89 Earl Street
PO Box 1145
Narrogin WA 6312

(08) 9890 0900

www.narrogin.wa.gov.au
enquiries@narrogin.wa.gov.au

CASHIER HOURS:
8:30am – 4:30pm
MONDAY- FRIDAY

The Shire of Narrogin provides funding assistance through the biannual Community Chest funding program to eligible community organisations for events or projects which benefit the Narrogin community. To support the recovery of community groups following the COVID crisis, and for the financial year 2020/2021 cash and in-kind support is available up to a maximum of \$5,000. To further support the recovery process, successful applicants from 2019/2020 and 2018/2019 are eligible and invited to apply.

1. APPLICANT DETAILS

Name of Organisation

WEST COAST JET SPRINT CLUB

Postal Address

10 FLEET CIRCLE HIGH WYCOMBE 6057

Contact Person

SIMON CAIN DIANNE WARD

Position

PRESIDENT SECRETARY

Phone

[Redacted Phone Number]

Email

[Redacted Email Address]

Organisation's ABN

21 439 924 182

Is your organisation registered for GST?

Yes No

Please attach a copy of your organisations Certificate of Incorporation

Yes No

2. PROJECT DETAILS

What is the name of your proposed project or event?

WEST COAST JET SPRINT RACING

Please provide a brief description of project / event (*maximum of 100 words*)

WEST COAST JET SPRINT RACING INVOLVES DIFFERENT CLASSES OF JET SPRINT BOATS. EACH BOAT HAS A DRIVER AND NAVIGATOR WHO NEGOTIATE THE COURSE IN A PRE DETERMINED DIRECTION WHICH IS PROVIDED TO THEM PRIOR TO THE DAY. THIS COURSE CONSISTS OF MANY DIRECTION CHANGES. EACH COMPETITOR HAS 4-6 QUALIFYING RUNS TO LEARN THE TRACK BEFORE GOING INTO THE ELIMINATION ROUND. THE TOP 3 DRIVERS WILL THEN COMPETE AGAINST EACH OTHER IN THE FINAL ROUND.

How will your project / event benefit the Narrogin community?

WE WILL HOLD THIS EVENT AS A FREE ENTRY EVENT FOR SPECTATORS OF ALL AGES MAKING IT A GREAT OPPORTUNITY FOR ALL OF THE FAMILY AND FRIENDS TO GET TOGETHER TO ENJOY AN EVENT THAT MANY MAY HAVE NEVER SEEN. IT WOULD BRING A FINANCIAL RETURN TO NARROGIN AS DRIVERS/NAVIGATORS/THEIR CREW AND OUR DEDICATED FOLLOWERS WOULD UTILISE LOCAL FACILITIES AN OPPORTUNITY FOR LOCAL BUSINESS TO GET INVOLVED SUPPLY FOOD/DRINKS ETC AT THE EVENT. SPECTATORS ARE ABLE GET INVOLVED WITH OUR "RIDE OF YOUR LIFE" AN INEXPENSIVE WAY TO FEEL THE ADRENALINE RUSH OF SITTING IN THE NAVIGATORS SEAT RACING AROUND THE COURSE. WE ALSO HAVE JUNIOR RACERS (AGES 8-14).

Estimated project start date

TBA

Estimated project completion date

TBA

3. ADVERTISING AND PROMOTION

It is a requirement of funding approval that the words "*Sponsored by the Shire of Narrogin*" and the Shire's logo be displayed at /on your project/event.

Please tick the boxes below to indicate the ways you will be able to acknowledge Shire of Narrogin sponsorship:

- Facebook, Instagram, or Twitter posts – please share with, and tag Shire of Narrogin page;
- Display Shire of Narrogin Logo: on your website and posters, in newspaper advertisements, on event signage, programs and flyers;
- Display the Shire of Narrogin flag or banner at your event if possible. (*Available upon request*)
- Affix Community Chest sign on project (*available on request*)
- Verbal announcements at event

4. PREVIOUS COMMUNITY CHEST FUNDING

Has your organisation previously received Community Chest funding?

Yes No

If yes, please tell us what year, and describe the project and the amount of Community Chest funds received

4. PROJECT BUDGET

Are you applying for cash or in-kind support, or both (*up to a combined maximum of \$2,500*)?

CASH

If you are requesting an in-kind contribution, please provide details below:

Please tell us how the Community Chest funds will be used?

THEY WOULD BE USED FOR PROGRAMS TO BE SUPPLIED TO SPECTATORS
AMBULANCE COVER
MEDIA
VOLUNTEERS MEALS

P/A SYSTEM ? FROM LOCAL BUSINESS
BUNTING /HALE BAYS
HIRE EQUIPMENT - GENERATOR, WATER PUMP
DIESEL FUEL
TOILET BLOCKS
PARKING ATTENDANTS FROM COMMUNITY VOLUNTEERS

If you are requesting cash, do you require the Community Chest funds prior to your proposed event / activity?

Yes No

Declaration

I declare that I am authorised to prepare and submit this application, and that the information presented is correct to the best of my knowledge

Name of President or Vice President

SIMON CAIN

Signature of President or Vice President

Simon Cain

Date

30/08/2020

ASSOCIATIONS INCORPORATION ACT 1987
SECTION 9 (1)

Registered No. 1004832

Certificate of Incorporation

This is to certify that

WEST COAST JET SPRINT CLUB (INC.)

has this day been incorporated under the
Associations Incorporation Act 1987

Dated this 17th day of August 1995

FOR THE COMMISSIONER FOR CORPORATE AFFAIRS

COMMUNITY CHEST APPLICATION FORM (FDRS010)



89 Earl Street
PO Box 1145
Narrogin WA 6312

(08) 9890 0900

www.narrogin.wa.gov.au
enquiries@narrogin.wa.gov.au

CASHIER HOURS:
8:30am – 4:30pm
MONDAY- FRIDAY

The Shire of Narrogin provides funding assistance through the biannual Community Chest funding program to eligible community organisations for events or projects which benefit the Narrogin community. To support the recovery of community groups following the COVID crisis, and for the financial year 2020/2021 cash and in-kind support is available up to a maximum of \$5,000. To further support the recovery process, successful applicants from 2019/2020 and 2018/2019 are eligible and invited to apply.

1. APPLICANT DETAILS

Name of Organisation

The Salvation Army (WA) Property Trust – Narrogin Corps

Postal Address

PO Box 325 Narrogin WA 6312

Contact Person

Major Niall Gibson

Position

Corps Officer

Phone

9881 4004 0419 132 305

Email

niall.gibson@salvationarmy.org.au

Organisation's ABN

25 878 329 270

Is your organisation registered for GST?

Yes

Please attach a copy of your organisations Certificate of Incorporation

Certificate of Incorporation is attached

2. PROJECT DETAILS

What is the name of your proposed project or event?

Thrift Shop fit out

Please provide a brief description of project / event (*maximum of 100 words*)

We are proposing to lease a shop in Federal Street. With this comes the expense to fit out the shop with
suitable fittings.

How will your project / event benefit the Narrogin community?

Our Thrift Shop provides good second hand clothing, furniture and Bric-a-brac to the Narrogin
Community and surrounds. The money raised from the shop helps us in delivering the mission of The
Salvation Army, including supplying clothing and furniture to those who need it through our Doorways
(Emergency Relief) Office.

Estimated project start date

10-Sep-2020

Estimated project completion date

06-Nov-20

3. ADVERTISING AND PROMOTION

It is a requirement of funding approval that the words "*Sponsored by the Shire of Narrogin*" and the Shire's logo be displayed at /on your project/event.

Please check the boxes below to indicate the ways you will be able to acknowledge Shire of Narrogin sponsorship:

- Facebook, Instagram, or Twitter posts – please share with, and tag Shire of Narrogin page;
- Display Shire of Narrogin Logo: on your website and posters, in newspaper advertisements, on event signage, programs and flyers;
- Display the Shire of Narrogin flag or banner at your event if possible. (*Available upon request*)
- Affix Community Chest sign on project (*available on request*)
- Verbal announcements at event

P

4. PREVIOUS COMMUNITY CHEST FUNDING

Has your organisation previously received Community Chest funding?

No

If yes, please tell us what year, and describe the project and the amount of Community Chest funds received:

5. PROJECT BUDGET

Are you applying for cash or in-kind support, or both (*up to a combined maximum of \$2,500*)?

Cash

If you are requesting an in-kind contribution, please provide details below:

Please tell us how the Community Chest funds will be used?

To supply shop fittings

If you are requesting cash, do you require the Community Chest funds prior to your proposed event / activity?

Yes

In-kind contributions:

Please calculate and list below the value of any in-kind contributions and include in the Total Project Budget; (e.g. volunteer or donated labour.)

Volunteer and donated labour is calculated at \$25 per hour per person

<i>Contributions</i>	<i>Estimated value \$</i>

Project Income and Expenditure

INCOME		EXPENDITURE (please attach quotes)	
**Amount of Community Chest Funds requested in cash	\$5000.00	Materials	\$14701.85
**Amount of Community Chest funds requested in-kind (e.g. Town Hall hire fee waived if applicable /required).	\$	Hire of equipment:	\$
Applicant's cash contribution	\$10551.85	Venue hire	\$
In-kind (volunteer, donated labour)	\$	Labour/contractor costs	\$
Sponsorship	\$	Advertising	\$
Donations (cash/materials from others- please list)	\$	Catering costs	\$
Other grants	\$	Entertainment	\$
Sales (stall fees, event tickets/food/merchandise)	\$	Office/administration	\$
Other income (please list)	\$	Other expenditure (please list)	\$850.00
TOTAL *INCOME	\$15551.85	TOTAL *EXPENDITURE	\$15551.85

**Income and *Expenditure amounts must be equal*

***The total combined Community Chest cash and in-kind request cannot be greater than \$2,500.*

Declaration

I declare that I am authorised to prepare and submit this application, and that the information presented is correct to the best of my knowledge.

Name of President or Vice President

Brad Potter

Signature of President or Vice President

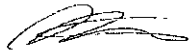

Date

26/08/20



Attachment 1
QUOTATION

Salesperson: **FABIAN ALBERTINI**
 Branch: **WESTERN AUSTRALI**
 Cust Acct No: **22292**
 Cust Order No **NIALL**

Quote No. **612134**

Date: **09.12.19**
 Due Date **07.01.20**
 Terms **30 Days EOM**

Customer Details THE SALVATION ARMY - SALVOS STORES (N PO BOX 479 BLACKBURN VIC 3130 Tel 08 9256 4639 Fax 08 9256 2941 Mob	Delivery Details THE SALVATION ARMY - SALVOS S Deliver to 50 FEDERAL ST NARROGIN WA 6312	Instructions Despatch by 11
--	--	---

Stock Code	Description	Order Qty	Unit Price (incl GST)	Price Code	Total Order (incl GST)
NOTE:	WALL POSTS & SHELVING: 19 X 1200mm WALL BAYS - TOP SHELF IN EACH. (INCLUDES 20 X ANGLED SHELVES FOR FOOTWEAR)	1			\$0.00
E1124CH	MAXe single sided post 2360 mm H (not for feet/joining rail) 32 W x 32 mm D Each or in box of 5 Chrome	26	\$38.00		\$988.00
E6312.BWH	MAXe Laminated Timber Shelf To Fit 1200 mm Bay 1193.5 L x 300D x 30mm Thick Each or skid of 80 White	39	\$31.25		\$1,218.75
E6003CH	MAXe 30 mm shelf bracket set 300 mm D 30 H x 2.5 mm Thick Each or in box of 20 Chrome	19	\$10.60		\$201.40
E6103CH	MAXe Multi Angle Bracket Set 300mm Deep, 30mm Thick Shelf 300 L x 2.5mm Thick Each or in box of 20 Chrome.	20	\$10.05		\$201.00
E7012CH	MAXe 30 mm shelf lip 52 H - 1200 mm bay 1193 W x 2.5 mm Thick Each or in box of 10 Chrome	20	\$9.90		\$198.00
NOTE:	MAXe ACCESSORIES:	1			\$0.00
E4012CH	MAXe backrail 1200 mm bay 1198 W x 32 H x 12.7 mm D Each or in box of 10 Chrome	30	\$24.05		\$721.50
E4830CH	MAXe backrail straight arm 300 mm D 18 x 18 mm section Each or in box of 25 Chrome	50	\$10.80		\$540.00
E4860CH	MAXe backrail angled arm with 5 hooks 405 mm D 18 x 18 mm section Each or in box of 25 Chrome	20	\$11.35		\$227.00
E4925CH	MAXe backrail hook 250 mm D 6 mm DIA wire Each or in box of 100 Chrome	100	\$1.45		\$145.00



Attachment 1
QUOTATION

Salesperson: **FABIAN ALBERTINI**
 Branch: **WESTERN AUSTRALI**
 Cust Acct No: **22292**
 Cust Order No **NIALL**

Quote No. **612134**

Date: **09.12.19**
 Due Date **07.01.20**
 Terms **30 Days EOM**

Customer Details THE SALVATION ARMY - SALVOS STORES (N PO BOX 479 BLACKBURN VIC 3130 Tel 08 9256 4639 Fax 08 9256 2941 Mob	Delivery Details THE SALVATION ARMY - SALVOS S Deliver to 50 FEDERAL ST NARROGIN WA 6312	Instructions Despatch by 11
--	---	---

Stock Code	Description	Order Qty	Unit Price (incl GST)	Price Code	Total Order (incl GST)
E4380CH	MAXe backrail basket 293 W x 200 H x 212 mm D Each or in box of 2 Chrome	8	\$23.80		\$190.40
E4212CH	MAXe hangrail 1200 mm bay 32 H x 12.7 D - 237 mm offset Each or in box of 4 Chrome	24	\$33.90		\$813.60
E8212WH	MAXe slatwall mesh panel 560 H - 1200 mm bay 1190 W x 18 mm Thick Each or in box of 4 White.	12	\$36.50		\$438.00
NOTE:	GONDOLA SHELVING UNITS ON CASTORS: ** 4 SHELVES EACH SIDE / ALL ROUND **	1			\$0.00
E0613.4WTS	MAXe H frame gondola 1200 bay & 2 x 600 mm end bays 1294 W x 632 D x 1240 mm H Each White sand	7	\$177.95		\$1,245.65
E6813.4WH	MAXe 18 mm H frame gondola top - small 1285 W x 450 D x 18 mm Thick Each White	7	\$42.00		\$294.00
E1070.4CH	MAXe castor 75 DIA x 21 W x 100 mm H - M10 Each or in box of 50 Chrome	14	\$5.00		\$70.00
E1071.4CH	MAXe castor with brake 75 DIA x 21 W x 100 mm H - M10 Each or in box of 50 Chrome	14	\$6.00		\$84.00
E6312.BWH	MAXe Laminated Timber Shelf To Fit 1200 mm Bay 1193.5 L x 300D x 30mm Thick Each or skid of 80 White	56	\$31.25		\$1,750.00
E6306.BWH	MAXe Laminated Timber Shelf To Fit 600 mm Bay 593.5 L x 300 D x 30mm Thick Each or skid of 80 White	56	\$24.25		\$1,358.00
E6003CH	MAXe 30 mm shelf bracket set 300 mm D 30 H x 2.5 mm Thick Each or in box of 20 Chrome	112	\$10.60		\$1,187.20



Attachment 1
QUOTATION

Salesperson: **FABIAN ALBERTINI**
 Branch: **WESTERN AUSTRALI**
 Cust Acct No: **22292**
 Cust Order No **NIALL**

Quote No. **612134**
 Date: **09.12.19**
 Due Date **07.01.20**
 Terms **30 Days EOM**

Customer Details THE SALVATION ARMY - SALVOS STORES (N PO BOX 479 BLACKBURN VIC 3130 Tel 08 9256 4639 Fax 08 9256 2941 Mob	Delivery Details THE SALVATION ARMY - SALVOS S Deliver to 50 FEDERAL ST NARROGIN WA 6312	Instructions Despatch by 11
---	---	--

Stock Code	Description	Order Qty	Unit Price (incl GST)	Price Code	Total Order (incl GST)
NOTE:	OTHER POSSIBLE REQUIREMENTS:	1			\$0.00
R1260CH	Heavy duty double rail clothes rack with adjustable rails 1530 W x 560 D x 1280-1800 mmH Ready to Assemble from 2 Boxes Chrome	12	\$116.00		\$1,392.00
R1261CH	Cross bar for R1260CH heavy duty clothes rack 615 D x 31.8 W x 12.7 mm Thick Each or in box of 20 Chrome	10	\$11.00		\$110.00
R1265CH	Connecting rail for R1260CH heavy duty clothes rack 1525 mm W Each or in box of 2 Chrome	8	\$14.10		\$112.80
R4100CH	Wire shelving system post with glide 1500 mm H x 25.4 mm DIA Each or in box of 4 Chrome	12	\$12.35		\$148.20
R4103CH	Wire shelving system shelf 1200 W x 450 mm Deep Each or in box of 4 Chrome	12	\$34.10		\$409.20
F4012WH	Counter 1200 mm with timber laminate with adjustable shelf 1200 W x 1000 H x 544 mm D Ready to assemble from 3 boxes White	1	\$238.15		\$238.15
F4018WH	Counter 1800 mm w timber lamin. With adjustable shelf 1800 W x 1000 H x 544 mm D Ready to assemble from 4 boxes White	1	\$420.00		\$420.00
FRSTIRLING	Stirling Freight Express	1	\$850.00		\$850.00

QUOTE VALID FOR 30 DAYS	Total (excl GST)	\$14,138.05
Payment Details: NAB BSB 083-064 A/c 48044 2667	GST	\$1,413.80
Please send remittance advice to: Email accounts@shopforshops.com or fax 03 9419 3476	Total (incl GST)	\$15,551.85
	Paid	
Title of any goods sold by Shop for Shops does not pass to the purchaser until the account has been settled in full. Exchanges and refunds are at the sole discretion of Shop for Shops. For our full Trading Terms please see page 315 of The Retailers' Catalogue 20, check our website	Balance	\$15,551.85



Attachment 1
QUOTATION

Quote No. **612134**

Salesperson: **FABIAN ALBERTINI**
Branch: **WESTERN AUSTRALI**
Cust Acct No: **22292**
Cust Order No **NIALL**

Date: **09.12.19**
Due Date **07.01.20**
Terms **30 Days EOM**

Customer Details THE SALVATION ARMY - SALVOS STORES (N PO BOX 479 BLACKBURN VIC 3130 Tel 08 9256 4639 Fax 08 9256 2941 Mob	Delivery Details THE SALVATION ARMY - SALVOS S Deliver to 50 FEDERAL ST NARROGIN WA 6312	Instructions Despatch by 11
--	---	--

Stock Code	Description	Order Qty	Unit Price (incl GST)	Price Code	Total Order (incl GST)
------------	-------------	-----------	-----------------------	------------	------------------------

Melbourne
89 Langridge Street
COLLINGWOOD VIC 3066

Sydney - City
10/476 Gardeners Rd
ALEXANDRIA NSW 2015

Sydney - West
211 Woodville Road
VILLAWOOD NSW 2163

Perth
Unit 1/52 Hector Street West
OSBORNE PARK WA 6017



11. ELECTED MEMBERS' MOTIONS OF WHICH PREVIOUS NOTICE HAS BEEN GIVEN

Revocation Motion

Councillor Bartron has submitted a revocation motion in accordance with the Council's Standing Orders Local Laws as below.

The following commentary is replicated from the Council Meeting of 24 April 2019 and is submitted as still being valid today. The Administration would recommend that the Revocation Motion be lost on that basis.

"The EMTRS enquired with a local concrete supplier/installer as to the cost to add colour to new concrete footpaths and if there would be a problem with matching the colour for each truck load of concrete per site and to future footpath sites. The local supplier estimated that an additional \$10 ex GST per linear metre based on a 1.8 metre wide footpath would be a close estimate. Currently the linear metre cost (for budgeting purposes), to supply and install (inclusive of site works) footpath concrete at 1.8 metre wide is based on around \$100 ex GST. For example, a footpath of 200 metres in length without colour would cost \$22,000 inc GST. The same footpath with colour added would cost \$24,200 inc GST. Please note that any footpath capital works are put out to the market whereby request for quotes are invited to achieve the most competitive rate and best quality of workmanship.

The supplier also commented that matching colours could not guarantee that a 100% match would be achieved. In addition the Shire Works Crew often undertakes 'patch' repairs whereby a 'patchwork' approach to colours could be the result in an otherwise continuous 'concrete' colour. The Works Program has progressively implemented a concrete coloured footpath network in Narrogin townsite now for at least 5 years".

ELECTED MEMBERS' MOTIONS (2) - SUBMITTED BY CR BARTRON AND SUPPORTED BY CR SEALE AND CR EARLY

That Council rescind resolution number 0419.10 from April 2019 as follows:

That Council adopt the Proposed Ten Year Footpath Construction Program 2019-2029 as presented and not accept the request of the Townscape Committee's to ensure that all future concrete footpaths be finished to match the existing red coloured asphalt footpaths, as it will:

1. Add additional cost;
2. Not guarantee a continuously same coloured footpath network; and
3. Run the risk of the network being seen as further disjointed.

BY ABSOLUTE MAJORITY

Should that motion succeed by an Absolute Majority Decision of the Council, the following motion also be put:

That Council adopt the Proposed Ten Year Footpath Construction Program 2019-2029 as presented and accept the request of the Townscape Committee's to ensure that all future concrete footpaths be finished to match the existing red coloured asphalt footpaths as much as possible.

12. NEW BUSINESS OF AN URGENT NATURE APPROVED BY THE PERSON PRESIDING OR BY DECISION OF THE MEETING

13. CLOSURE OF MEETING

There being no further business to discuss, the Presiding Member declared the meeting closed at pm and pursuant to Resolution 1219.010 of 18 December 2019, reminded Councillors of the next Ordinary Meeting of the Council, scheduled for 7.00 pm on Tuesday 27 October 2020, at this same venue.



89 Earl Street, Narrogin
Correspondence to:
PO Box 1145, Narrogin WA 6312
T (08) 9890 0900
E enquiries@narrogin.wa.gov.au
W www.narrogin.wa.gov.au